

PLUMBING 101

PROFESSIONAL DEVELOPMENT COURSE



**Technical
Learning
College**

Printing and Saving Instructions

The best thing to do is to download this pdf document to your computer desktop and open it with Adobe Acrobat DC reader.

Adobe Acrobat DC reader is a free computer software program and you can find it at Adobe Acrobat's website.

You can complete the course by viewing the course materials on your computer or you can print it out. We give you permission to print this document.

Printing Instructions:

If you are going to print this document, this document is designed to be printed double-sided or duplexed but can be single-sided.

This course booklet does not have the assignment. Please visit our website and download the assignment also.

Professional Engineers; Most states will accept our courses for credit but we do not officially list the States or Agencies.

Link to Assignment...

<http://www.tlch2o.com/PDF/Plumbing101Ass.pdf>

State Approval Listing Link, check to see if your State accepts or has pre-approved this course. Not all States are listed.

<http://www.tlch2o.com/PDF/CEU%20State%20Approvals.pdf>

You can obtain a printed version from TLC for an additional \$59.95 plus shipping charges.

Contributing Editors

Joseph Camerata has a BS in Management with honors (magna cum laude). He retired as a Chemist in 2006 having worked in the field of chemical, environmental, and industrial hygiene sampling and analysis for 40 years. He has been a professional presenter at an EPA analytical conference at the Biosphere in Arizona and a presenter at an AWWA conference in Mesa, Arizona. He also taught safety classes at the Honeywell and City of Phoenix, and is a motivational/inspirational speaker nationally and internationally.

Dr. Eric Pearce S.M.E., chemistry and biological review.

Dr. Pete Greer S.M.E., retired biology instructor.

Jack White, Environmental, Health, Safety expert. Art Credits.

Check with your State to see if this course has been accepted.



Basic Plumbing© www.abctlc.com 7/8/2002 All plastic piping photos are used by permission from Spears MFG. Co, All backflow materials are used by permission from CMB Industries, Inc.

Course Description

Plumbing 101 CEU Training Course

This eight hour CEU training course will train students in plumbing and backflow principles. This course was primarily designed to teach technical knowledge in basic plumbing procedures; to lay out, assemble, install, and maintain piping, fixtures, and piping systems for stream, hot water, heating, cooling, draining, lubricating, sprinkling, and industrial processing systems. Includes instruction in material selection and use of tools to cut, bend, join, and weld pipes. The student will also be able to identify and describe various backflow prevention methods and assemblies.

Audience

Water Distribution, Well Drillers, Pump Installers, Water Treatment Operators, Wastewater Treatment Operators, Wastewater Collection Operators, Industrial Wastewater Operators and General Backflow Assembly Testers, and Plumbers--the target audience for this course is the person interested in working in a water or wastewater treatment or distribution/collection facility, performing basic or light plumbing, wishing to maintain CEUs for a certification license, wanting to learn how to do the job safely and effectively, and/or to meet education needs for promotion.

Course Statement of Need

Plumbing systems are commonly found in water and wastewater facilities, the plumbing pipes and systems carry drinking water and wastewater. If the wastewater mixes with the drinking water, there is a chance people using that system could get sick. A plumbing system built and maintained according to the plumbing code is a safe system. Operators are generally responsible for protecting the water supply by ensuring, through plan review and inspections, that the plumbing has no cross-connections or possibility of backflow. Operators who preform simple plumbing repairs and maintenance are responsible for ensuring the waste plumbing is properly vented and trapped so the plumbing safely carries waste away while causing no health problems and prevent backflow prevention/cross-connection contamination.

Course Procedures for Registration and Support

All of Technical Learning College's correspondence courses have complete registration and support services offered. Delivery of services will include e-mail, web site, telephone, fax and mail support. TLC will attempt immediate and prompt service. When a student registers for a distance or correspondence course, he/she is assigned a start date and an end date. It is the student's responsibility to note dates for assignments and keep up with the course work. All students will be tracked by a unique number assigned to the student.

Instructions for Written Assignments

The Plumbing 101 CEU Training course will be a Fill-in-the-Blank type of exam. TLC will require that the document is typed and preferably e-mailed or faxed to TLC. You can find complete course support on TLC's website under the Assignment Page.

Feedback Mechanism (examination procedures)

Each student will receive a feedback form as part of their study packet. You will be able to find this form in the rear of the course or lesson.

Security and Integrity

All students are required to do their own work. All lesson sheets and final exams are not returned to the student to discourage sharing of answers. Any fraud or deceit and the student will forfeit all fees and the appropriate agency will be notified.

Grading Criteria

In order to successfully pass this course, you will need to have 70% or better on the final exam.

Required Texts

The ***Plumbing 101*** CEU Training course does not require any course materials. Course comes complete.



Educational Mission

The educational mission of TLC is:

To provide TLC students with comprehensive and ongoing training in the theory and skills needed for the environmental education field,

To provide TLC students with opportunities to apply and understand the theory and skills needed for operator certification,

To provide opportunities for TLC students to learn and practice environmental educational skills with members of the community for the purpose of sharing diverse perspectives and experience,

To provide a forum in which students can exchange experiences and ideas related to environmental education,

To provide a forum for the collection and dissemination of current information related to environmental education, and to maintain an environment that nurtures academic and personal growth.

Important Information about this Manual

This manual has been prepared to educate students and operators in general safety awareness of dealing with the often-complex and various water distribution devices, methods, and light plumbing applications. This manual will cover procedures and accepted policies relating to the use of water distribution, backflow protection devices, methods, and light plumbing applications.

It should be noted, however, that the regulation of plumbing and water distribution materials is an ongoing process and subject to change over time. For this reason, a list of resources is provided to assist in obtaining the most up-to-date information on various subjects.

This manual is not a guidance or code document for plumbers or operators. It is not designed to meet the requirements of the United States Environmental Protection Agency (**EPA**), Office of Health and Safety Administration (**OSHA**) or your local State environmental protection agency, health department, building code or plumbing enforcement agency. This course manual will provide general water distribution, piping and backflow protection information and should not be used as a basis for plumbing, backflow protection method/device guidance. This document is not a detailed plumbing code manual or a source or remedy for plumbing license or certification.

Technical Learning College or Technical Learning Consultants, Inc. makes no warranty, guarantee or representation as to the absolute correctness or appropriateness of the information in this manual and assumes no responsibility in connection with the implementation of this information. It cannot be assumed that this manual contains all measures and concepts required for specific conditions or circumstances. This document should be used for educational purposes only and is not considered a legal document. Individuals who are responsible for plumbing, water distribution systems, and backflow protection should obtain and comply with the most recent federal, state, and local regulations relevant to these sites and are urged to consult with OSHA, Building Authority, the EPA and other appropriate federal, state and local agencies.

Copyright Notice

©2005 Technical Learning College (TLC) No part of this work may be reproduced or distributed in any form or by any means without TLC's prior written approval. Permission has been sought for all images and text where we believe copyright exists and where the copyright holder is traceable and contactable. All material that is not credited or acknowledged is the copyright of Technical Learning College. This information is intended for educational purposes only. Most uncredited photographs have been taken by TLC instructors or TLC students. We will be pleased to hear from any copyright holder and will make good on your work if any unintentional copyright infringements were made as soon as these issues are brought to the editor's attention.

Every possible effort is made to ensure that all information provided in this course is accurate. All written, graphic, photographic or other material is provided for information only. Therefore, Technical Learning College accepts no responsibility or liability whatsoever for the application or misuse of any information included herein.

Requests for permission to make copies should be made to the following address:
TLC

P.O. Box 3060

Chino Valley, AZ 86323

Information in this document is subject to change without notice. TLC is not liable for errors or omissions appearing in this document.

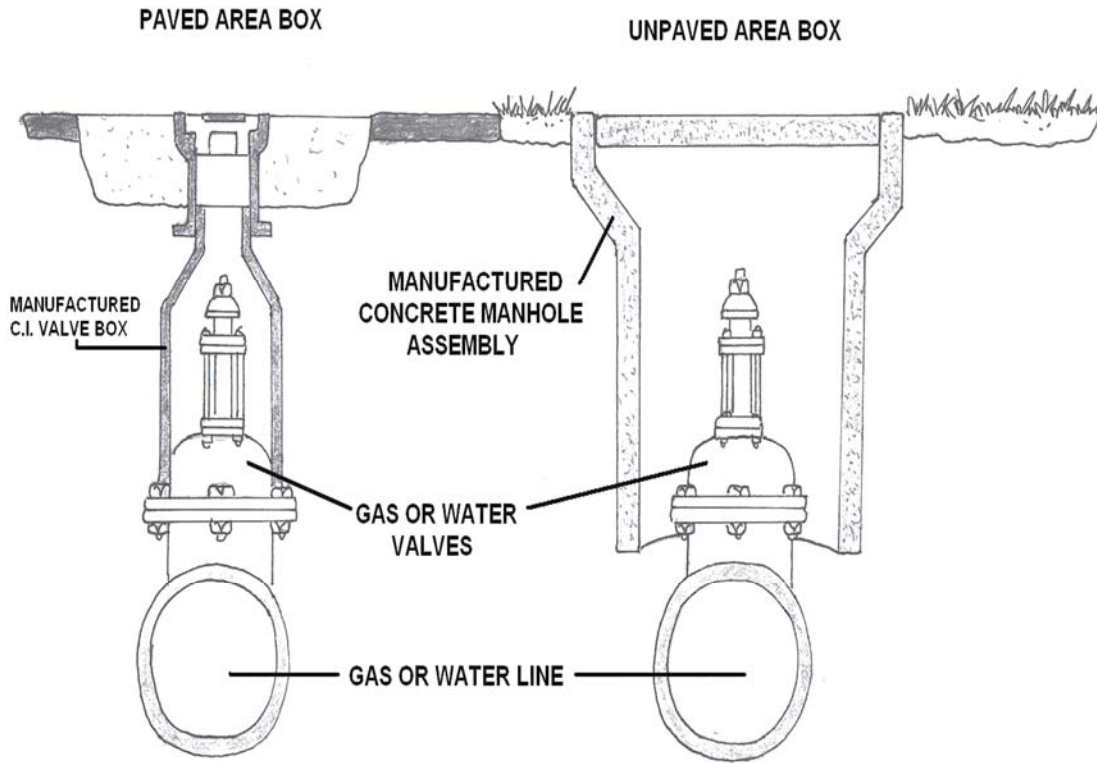

TYPICAL VALVE BOXES

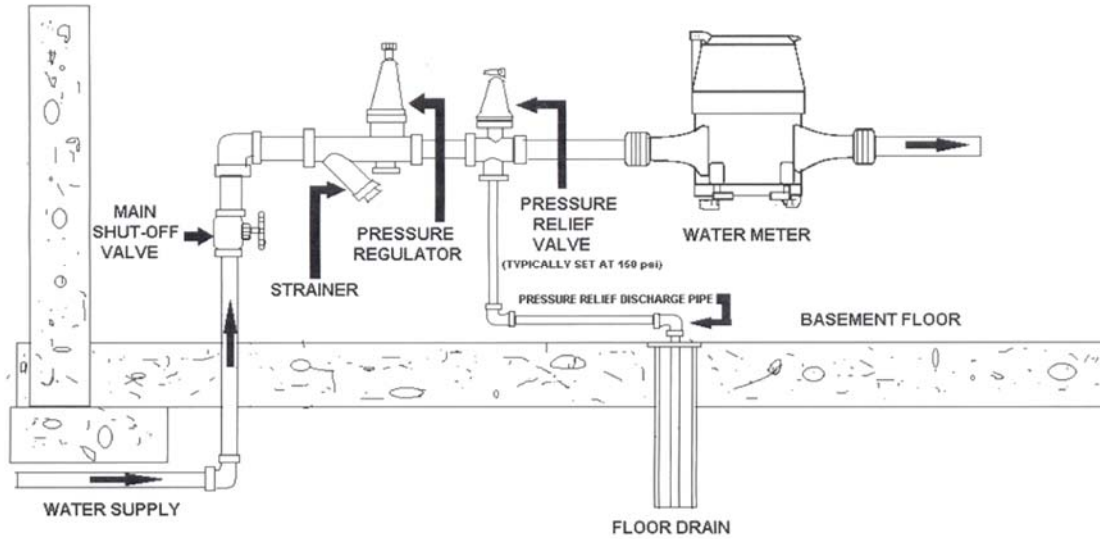
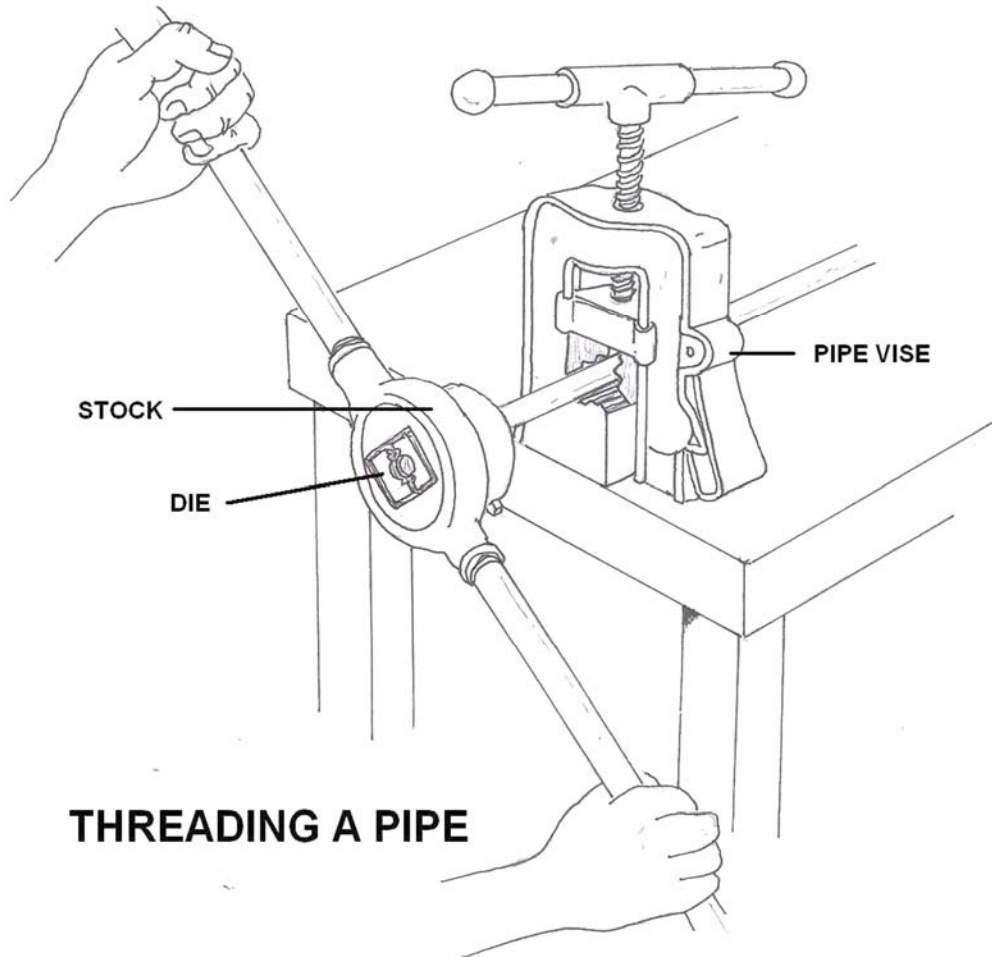

TABLE OF CONTENTS

HYDRAULIC PRINCIPLES CHAPTER 1	11
WATER PRESSURE.....	12
PRESSURE AND FORCE.....	14
PASCAL'S LAW.....	15
BERNOULLI'S PRINCIPLES.....	17
BACKFLOW CHAPTER 2	19
BACKSIPHONAGE.....	22
BACKPRESSURE.....	25
BACKFLOW RESPONSIBILITY.....	27
DEGREES OF HAZARD.....	29
AIR GAP.....	31
ATMOSPHERIC VACUUM BREAKER.....	33
DOUBLE CHECK.....	35
REDUCED PRESSURE.....	36
PLUMBING CODES.....	49
QUALITY OF WATER SUPPLY.....	53
PLUMBING FITTINGS CHAPTER 3	63
PLASTIC AND PIPE FITTINGS.....	65
SOLVENT CEMENTING.....	67
SUMMARY.....	72
TYPES OF JOINTS.....	73
UNIONS.....	78
PLUMBING REPAIRS CHAPTER 4	79
WORN FAUCET.....	84
BALL TYPE FAUCETS.....	87
WATER CLOSETS.....	91
SHOWER.....	101
GRAVITY SANITARY SEWERS.....	115
INFILTRATION AND INFLOW.....	125
DRAINS AND VENTS CHAPTER 5	131
SEWER GASES.....	133
DRAIN WASTE VENT SYSTEM.....	135
INDIRECT WASTE PIPING.....	141
WATER DISTRIBUTION SYSTEM CHAPTER 6	143
VALVE GLOSSARY.....	145
KNIFE GATE VALVE.....	149

COMMON ROTARY VALVES.....	155
BALL STOP.....	161
BUTTERFLY VALVE.....	163
ACTUATORS AND CONTROL DEVICES.....	167
PRESSURE REDUCING.....	175
VALVE EXERCISING.....	183
DISTRIBUTION PIPES.....	187
SOLDERING COPPER TUBING.....	191
DISTRIBUTION JOINTS AND FITTINGS.....	193
CATHODIC PROTECTION.....	197
WATER SERVICES PIPE INSTALLATION.....	199
GLOSSARY.....	211
MATH CONVERSIONS.....	221



Hydraulic Principles Chapter 1

Atmospheric Pressure

The atmosphere is the entire mass of air that surrounds the earth. While it extends upward for about 500 miles, the section of primary interest is the portion that rests on the earth's surface and extends upward for about 7 1/2 miles. This layer is called the troposphere. If a column of air 1-inch square extending all the way to the "top" of the atmosphere could be weighed, this column of air would weigh approximately 14.7 pounds at sea level. Thus, atmospheric pressure at sea level is approximately 14.7 psi.

As one ascends, the atmospheric pressure decreases by approximately 1.0 psi for every 2,343 feet. However, below sea level, in excavations and depressions, atmospheric pressure increases. Pressures under water differ from those under air only because the weight of the water must be added to the pressure of the air.

Atmospheric pressure can be measured by any of several methods. The common laboratory method uses the mercury column barometer. The height of the mercury column serves as an indicator of atmospheric pressure. At sea level and at a temperature of 0° Celsius (C), the height of the mercury column is approximately 30 inches, or 76 centimeters. This represents a pressure of approximately 14.7 psi. The 30-inch column is used as a reference standard.

Another device used to measure atmospheric pressure is the aneroid barometer. The aneroid barometer uses the change in shape of an evacuated metal cell to measure variations in atmospheric pressure. The thin metal of the aneroid cell moves in or out with the variation of pressure on its external surface. This movement is transmitted through a system of levers to a pointer, which indicates the pressure.

The atmospheric pressure does not vary uniformly with altitude. It changes more rapidly. Atmospheric pressure is defined as the force per unit area exerted against a surface by the weight of the air above that surface. In the diagram below, the pressure at point "X" increases as the weight of the air above it increases. The same can be said about decreasing pressure, where the pressure at point "X" decreases if the weight of the air above it also decreases.

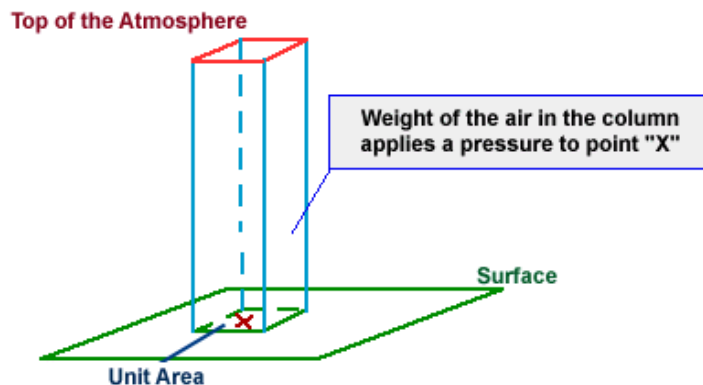

Pressure may be referred to using an absolute scale, pounds per square inch absolute (psia), or gauge scale, (psiag). Absolute pressure and gauge pressure are related.

Absolute pressure is equal to gauge pressure plus the atmospheric pressure. At sea level, the atmospheric pressure is 14.7 psia.

Absolute pressure is the total pressure. Gauge pressure is simply the pressure read on the gauge. If there is no pressure on the gauge other than atmospheric, the gauge will read zero. Then the absolute pressure would be equal to 14.7 psi, which is the atmospheric pressure.

Vacuum

The term *vacuum* indicates that the absolute pressure is less than the atmospheric pressure and that the gauge pressure is negative. A complete or total vacuum would mean a pressure of 0 psia or -14.7 psig.

Since it is impossible to produce a total vacuum, the term vacuum, as used in this document, will mean all degrees of partial vacuum.

In a partial vacuum, the pressure would range from slightly less than 14.7 psia (0 psig) to slightly greater than 0 psia (-14.7 psig).

Backsiphonage results from atmospheric pressure exerted on a liquid, forcing it toward a supply system that is under a vacuum.

Water Pressure

The weight of a cubic foot of water is 62.4 pounds per square foot. The base can be subdivided into 144-square inches with each subdivision being subjected to a pressure of 0.433 psig.

Suppose you placed another cubic foot of water on top of the first cubic foot. The pressure on the top surface of the first cube which was originally atmospheric, or 0 psig, would now be 0.4333 psig as a result of the additional cubic foot of water. The pressure of the base of the first cubic foot would be increased by the same amount of 0.866 psig or two times the original pressure.

Hydraulics

The word *hydraulics* is based on the Greek word for water, and originally covered the study of the physical behavior of water at rest and in motion.

Use has broadened its meaning to include the behavior of all liquids, although it is primarily concerned with the motion of liquids. Hydraulics include the manner in which liquids act in tanks and pipes, deals with their properties, and explores ways to take advantage of these properties.

Hydraulics is a branch of engineering concerned mainly with moving liquids. The term is applied commonly to the study of the mechanical properties of water, other liquids, and even gases when the effects of compressibility are small. Hydraulics can be divided into two areas, hydrostatics and hydrokinetics. Hydrostatics, the consideration of liquids at rest, involves problems of buoyancy and flotation, pressure on dams and submerged devices, and hydraulic presses.

Hydrodynamics

The relative incompressibility of liquids is one of its basic principles. Hydrodynamics, the study of liquids in motion, is concerned with such matters as friction and turbulence generated in pipes by flowing liquids, the flow of water over weirs and through nozzles, and the use of hydraulic pressure in machinery.

Development of Hydraulics

Although the modern development of hydraulics is comparatively recent, the ancients were familiar with many hydraulic principles and their applications. The Egyptians and the ancient people of Persia, India, and China conveyed water along channels for irrigation and domestic purposes, using dams and sluice gates to control the flow. The ancient Cretans had an elaborate plumbing system. Archimedes studied the laws of floating and submerged bodies. The Romans constructed aqueducts to carry water to their cities.

After the breakup of the ancient world, there were few new developments for many centuries. Then, over a comparatively short period, beginning near the end of the seventeenth century, Italian physicist Evangelista Torricelle, French physicist Edme Mariotte and, later, Daniel Bernoulli conducted experiments to study the elements of force in the discharge of water through small openings in the sides of tanks and through short pipes.

During the same period, Blaise Pascal, a French scientist, discovered the fundamental law for the science of hydraulics. Pascal's law states that increase in pressure on the surface of a confined fluid is transmitted undiminished throughout the confining vessel or system.

For Pascal's law to be made effective for practical applications, it was necessary to have a piston that "fit exactly." It was not until the latter part of the eighteenth century that methods were found to make these snugly fitted parts required in hydraulic systems.

This was accomplished by the invention of machines that were used to cut and shape the necessary closely fitted parts and, particularly, by the development of gaskets and packings. Since that time, components such as valves, pumps, actuating cylinders, and motors have been developed and refined to make hydraulics one of the leading methods of transmitting power.

Liquids are almost incompressible. For example, if a pressure of 100 pounds per square inch (psi) is applied to a given volume of water that is at atmospheric pressure, the volume will decrease by only 0.03 percent. It would take a force of approximately 32 tons to reduce its volume by 10 percent; however, when this force is removed, the water immediately returns to its original volume. Other liquids behave in about the same manner as water.

Another characteristic of a liquid is the tendency to keep its free surface level. If the surface is not level, liquids will flow in the direction which will tend to *make* the surface level.

Liquids at Rest

In studying fluids at rest, we are concerned with the transmission of force and the factors which affect the forces in liquids. Additionally, pressure in and on liquids and factors affecting pressure are of great importance.

Pressure and Force

Pressure is the force that pushes water through pipes. Water pressure determines the flow of water from the tap. If pressure is not sufficient then the flow can reduce to a trickle and it will take a long time to fill a kettle or a cistern.

The terms *force* and *pressure* are used extensively in the study of fluid power. It is essential that we distinguish between the terms.

Force means a total push or pull. It is the push or pull exerted against the total area of a particular surface and is expressed in pounds or grams. Pressure means the amount of push or pull (force) applied to each unit area of the surface and is expressed in pounds per square inch (lb/in^2) or grams per square centimeter (gm/cm^2). Pressure may be exerted in one direction, in several directions, or in all directions.

Computing Force, Pressure, and Area

A formula is used in computing force, pressure, and area in fluid power systems. In this formula, P refers to pressure, F indicates force, and A represents area. Force equals pressure times area. Thus, the formula is written:



Pascal's Law

The foundation of modern hydraulics was established when Pascal discovered that pressure in a fluid acts equally in all directions. This pressure acts at right angles to the containing surfaces. If some type of pressure gauge, with an exposed face, is placed beneath the surface of a liquid at a specific depth and pointed in different directions, the pressure will read the same. Thus, we can say that pressure in a liquid is independent of direction.

Pressure due to the weight of a liquid, at any level, depends on the depth of the fluid from the surface. If the exposed face of the pressure gauges are moved closer to the surface of the liquid, the indicated pressure will be less. When the depth is doubled, the indicated pressure is doubled. Thus the pressure in a liquid is directly proportional to the depth.

Consider a container with vertical sides that is 1 foot long and 1 foot wide. Let it be filled with water 1 foot deep, providing 1 cubic foot of water. 1 cubic foot of water weighs 62.4 pounds. Using this information and equation, $P = F/A$, we can calculate the pressure on the bottom of the container.

Since there are 144 square inches in 1 square foot, this can be stated as follows: the weight of a column of water 1 foot high, having a cross-sectional area of 1 square inch, is 0.433 pound. If the depth of the column is tripled, the weight of the column will be 3×0.433 , or 1.299 pounds, and the pressure at the bottom will be 1.299 lb/in² (psi), since pressure equals the force divided by the area.

Thus, the pressure at any depth in a liquid is equal to the weight of the column of liquid at that depth divided by the cross-sectional area of the column at that depth.

The volume of a liquid that produces the pressure is referred to as the fluid head of the liquid. The pressure of a liquid due to its fluid head is also dependent on the density of the liquid.

Gravity

Gravity is one of the four forces of nature. The strength of the gravitational force between two objects depends on their masses. The more massive the objects are, the stronger the gravitational attraction.

When you pour water out of a container, the earth's gravity pulls the water towards the ground. The same thing happens when you put two buckets of water, with a tube between them, at two different heights. You must do work to start the flow of water from one bucket to the other, but then gravity takes over and the process will continue on its own.

Gravity, applied forces, and atmospheric pressure are static factors that apply equally to fluids at rest or in motion, while inertia and friction are dynamic factors that apply only to fluids in motion. The mathematical sum of gravity, applied force, and atmospheric pressure is the static pressure obtained at any one point in a fluid at any given time.

Static Pressure

Static pressure exists in addition to any dynamic factors that may also be present at the same time.

Pascal's law states that a pressure set up in a fluid acts equally in all directions and at right angles to the containing surfaces.

This covers the situation only for fluids at rest or practically at rest. It is true only for the factors making up static head. Obviously, when velocity becomes a factor it must have a direction, and as previously explained, the force related to the velocity must also have a direction, so that Pascal's law alone does not apply to the dynamic factors of fluid power.

The dynamic factors of inertia and friction are related to the static factors. Velocity head and friction head are obtained at the expense of static head. However, a portion of the velocity head can always be reconverted to static head.

Force, which can be produced by pressure or head when dealing with fluids, is necessary to start a body moving if it is at rest, and is present in some form when the motion of the body is arrested; therefore, whenever a fluid is given velocity, some part of its original static head is used to impart this velocity, which then exists as velocity head.

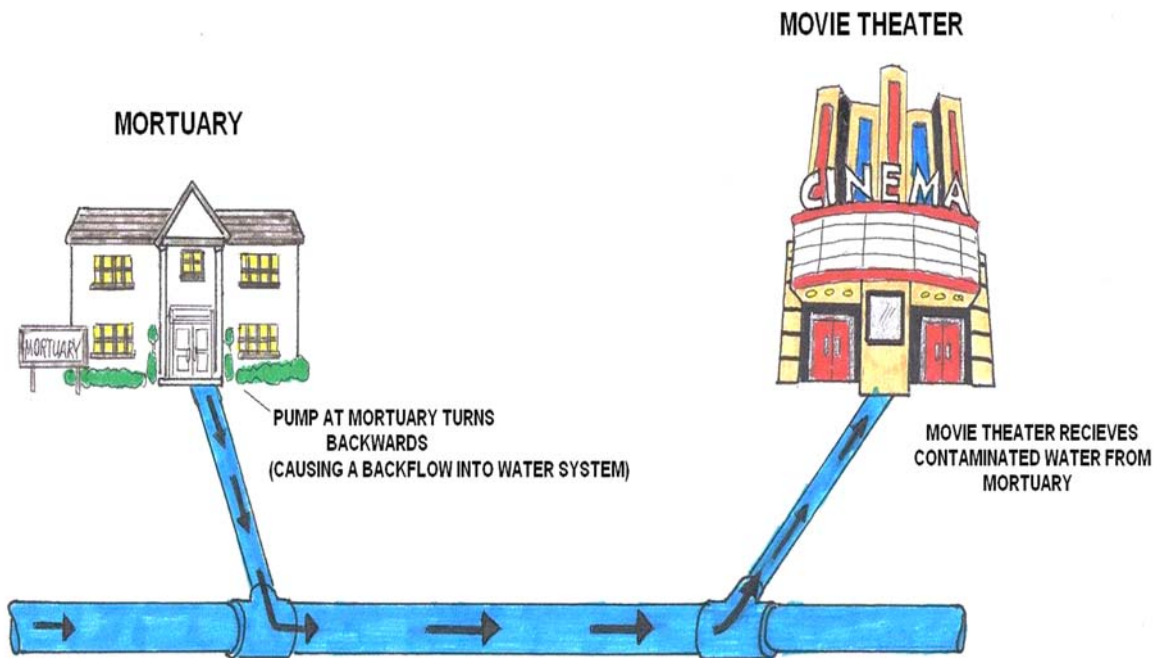

Volume and Velocity of Flow

The volume of a liquid passing a point in a given time is known as its *volume of flow* or flow rate. The volume of flow is usually expressed in gallons per minute (gpm) and is associated with relative pressures of the liquid, such as 5 gpm at 40 psi.

The *velocity of flow* or velocity of the fluid is defined as the average speed at which the fluid moves past a given point. It is usually expressed in feet per second (fps) or feet per minute (fpm). Velocity of flow is an important consideration in sizing the hydraulic lines.

Volume and velocity of flow are often considered together. With other conditions unaltered—that is, with volume of input unchanged—the velocity of flow increases as the cross section or size of the pipe decreases, and the velocity of flow decreases as the cross section increases. For example, the velocity of flow is slow at wide parts of a stream and rapid at narrow parts, yet the volume of water passing each part of the stream is the same.

Bernoulli's Principle

Bernoulli's principle thus says that a rise (fall) in pressure in a flowing fluid must always be accompanied by a decrease (increase) in the speed; and conversely, an increase (decrease) in the speed of the fluid results in a decrease (increase) in the pressure.

This is at the heart of a number of everyday phenomena. As a very trivial example, Bernoulli's principle is responsible for the fact that a shower curtain gets "*sucked inwards*" when the water is first turned on. What happens is that the increased water/air velocity inside the curtain (relative to the still air on the other side) causes a pressure drop.

The pressure difference between the outside and inside causes a net force on the shower curtain which sucks it inward. A more useful example is provided by the functioning of a perfume bottle: squeezing the bulb over the fluid creates a low-pressure area due to the higher speed of the air, which subsequently draws the fluid up. This is illustrated in the following figure.

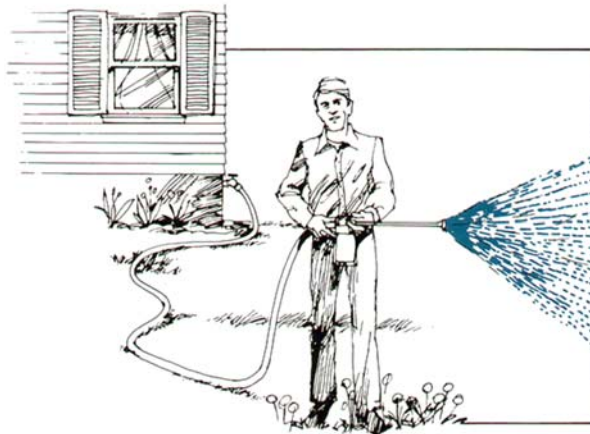

Action of a spray atomizer

Bernoulli's Principle Explained

Bernoulli's principle also tells us why windows tend to explode, rather than implode in hurricanes: the very high speed of the air just outside the window causes the pressure just outside to be much less than the pressure inside, where the air is still. The difference in force pushes the windows outward, and hence they explode. If you know that a hurricane is coming it is therefore better to open as many windows as possible, to equalize the pressure inside and out.

Another example of Bernoulli's principle at work is in the lift of aircraft wings and the motion of "curve balls" in baseball. In both cases, the design is such as to create a speed differential of the flowing air past the object on the top and the bottom - for aircraft wings this comes from the movement of the flaps, and for the baseball it is the presence of ridges. Such a speed differential leads to a pressure difference between the top and bottom of the object, resulting in a net force being exerted, either upwards or downwards.

Properties of Water

Specific gravity of water at 60°F = 1.00

Weight per gallon is based on 7.48052 gallons per cubic foot.

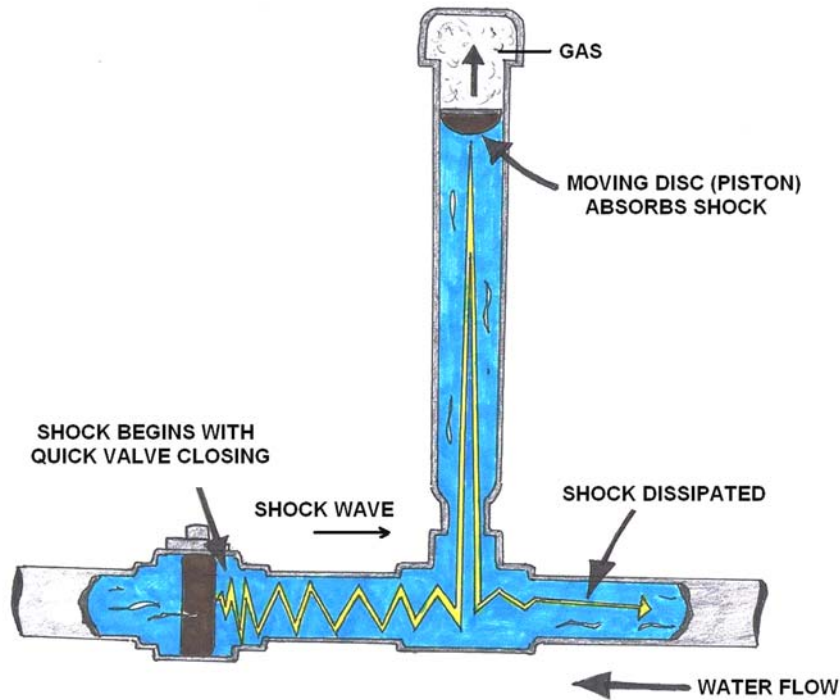

BASIC FUNCTION OF WATER HAMMER ARRESTER

Backflow Chapter 2

Cross-Connection Terms

Cross-connection

A cross-connection is any temporary or permanent connection between a public water system or consumer's potable (i.e., drinking) water system and any source or system containing nonpotable water or other substances.

An example is the piping between a public water system or consumer's potable water system and an auxiliary water system, cooling system, or irrigation system.

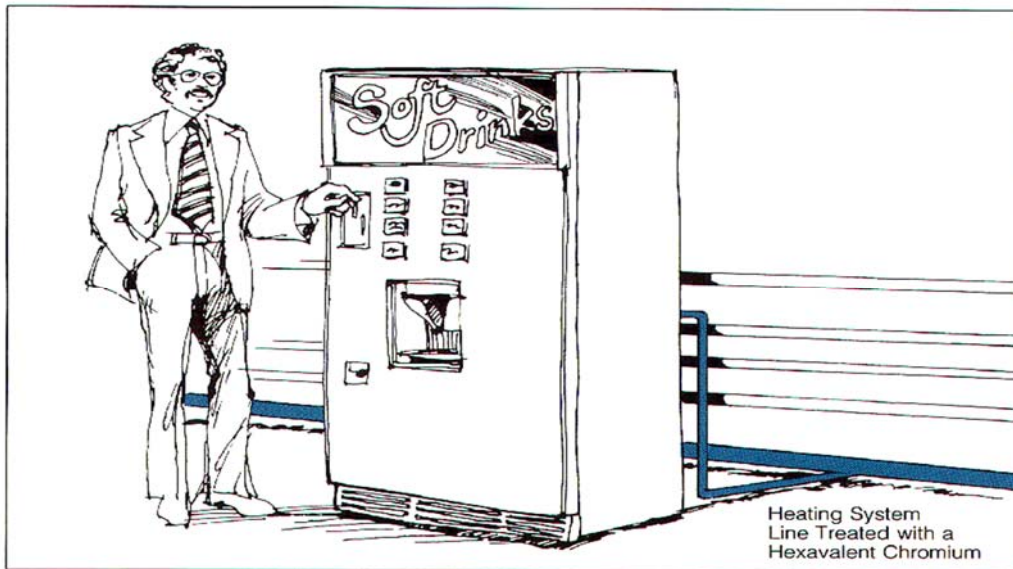
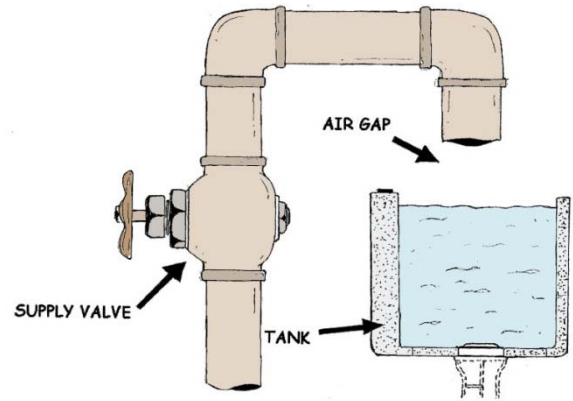

Common Cross-connections

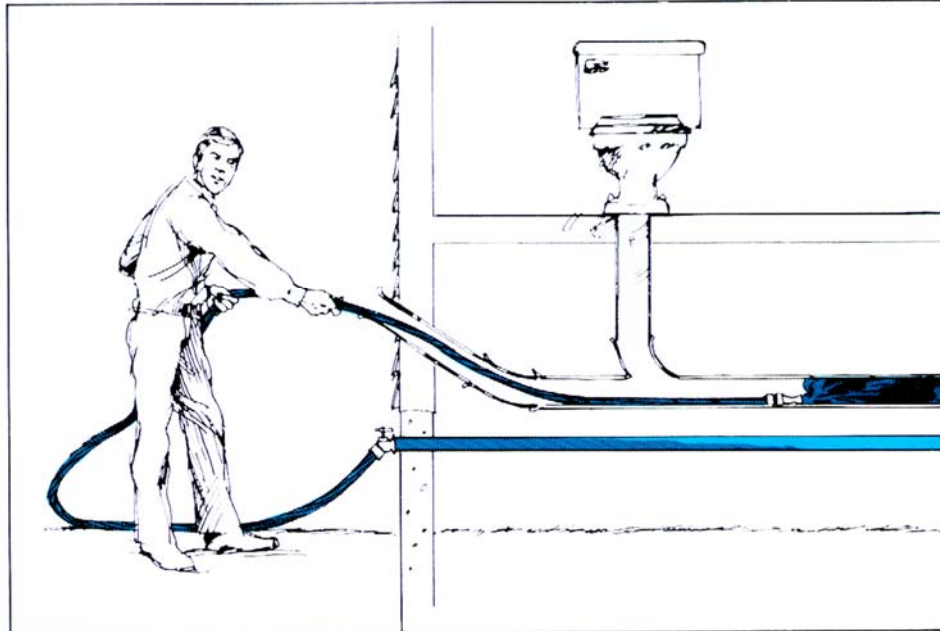
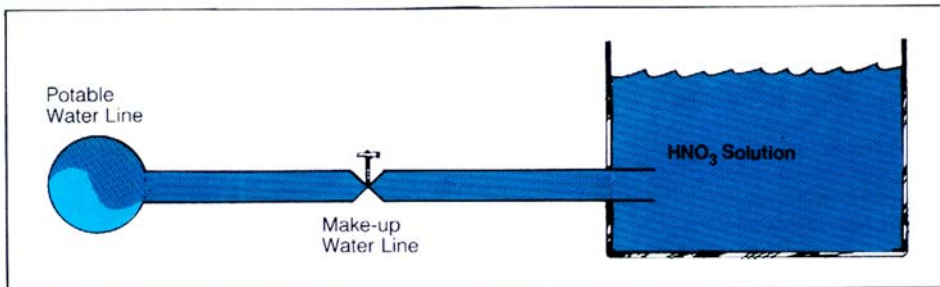
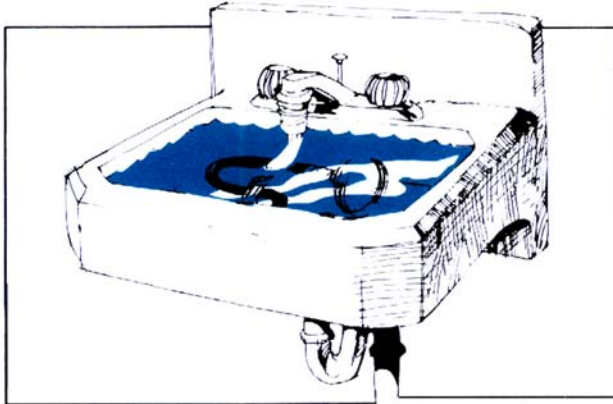

Backflow

Backflow is the undesirable reversal of flow of nonpotable water or other substances through a cross-connection and into the piping of a public water system or consumer's potable water system. There are two types of backflow--**backpressure** and **backsiphonage**.

Backsiphonage

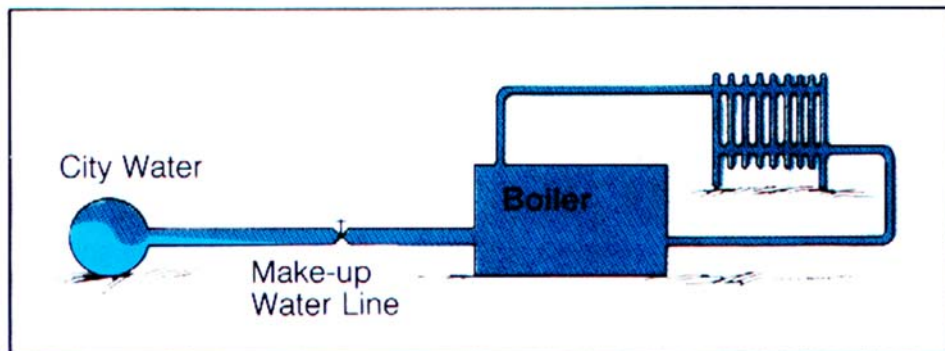

Backpressure

Backsiphonage

Backsiphonage is backflow caused by a negative pressure (i.e., a vacuum or partial vacuum) in a public water system or consumer's potable water system. The effect is similar to drinking water through a straw.

Backsiphonage can occur when there is a stoppage of water supply due to nearby fire-fighting, a break in a water main, etc.

All backflow materials are used by permission from CMB Industries, Inc

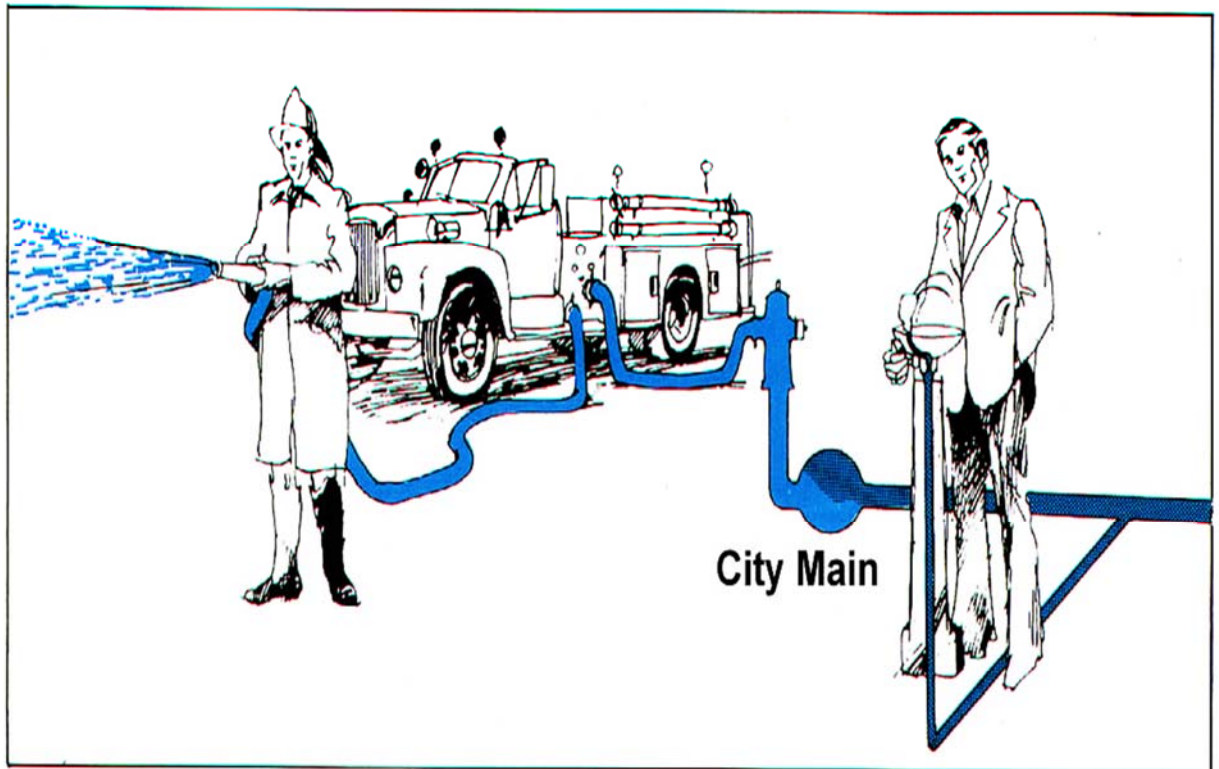

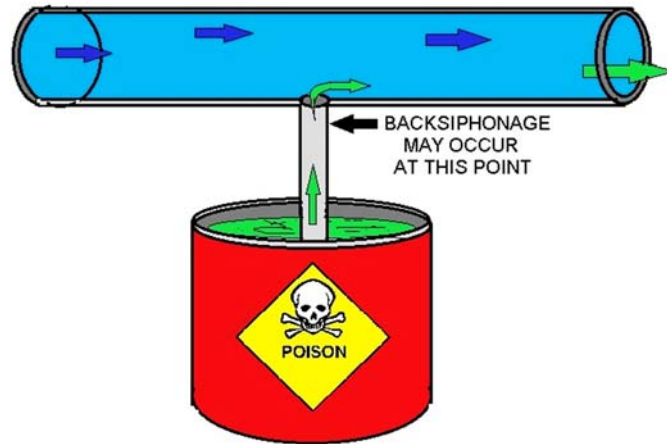

ASPIRATOR EFFECT

- 2 REVERSE PRESSURE IS CAUSED BY A DROP IN WATER PRESSURE. THIS DROP CAN CAUSE CHEMICALS TO BE DRAWN INTO THE DRINKING WATER SUPPLY.
(This is referred to as: Cross Connection)



- 1 WATER PRESSURE IS REDUCED BY BREAK IN MAIN WATER SUPPLY

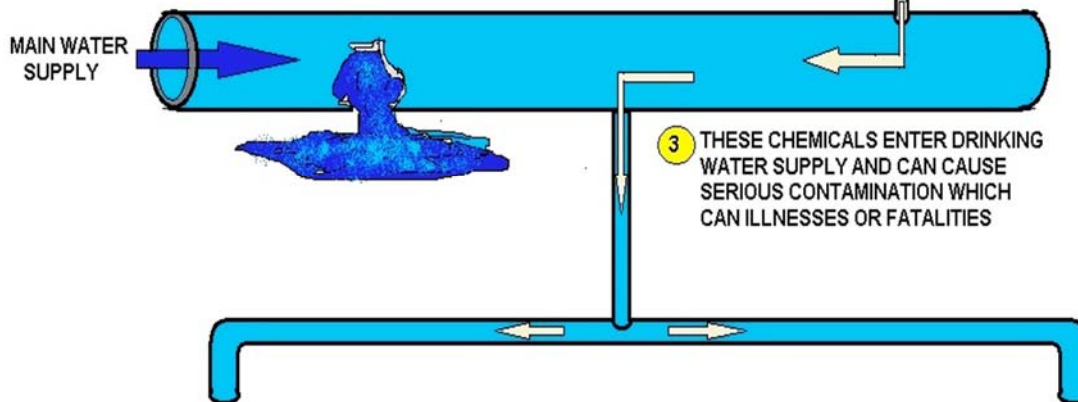

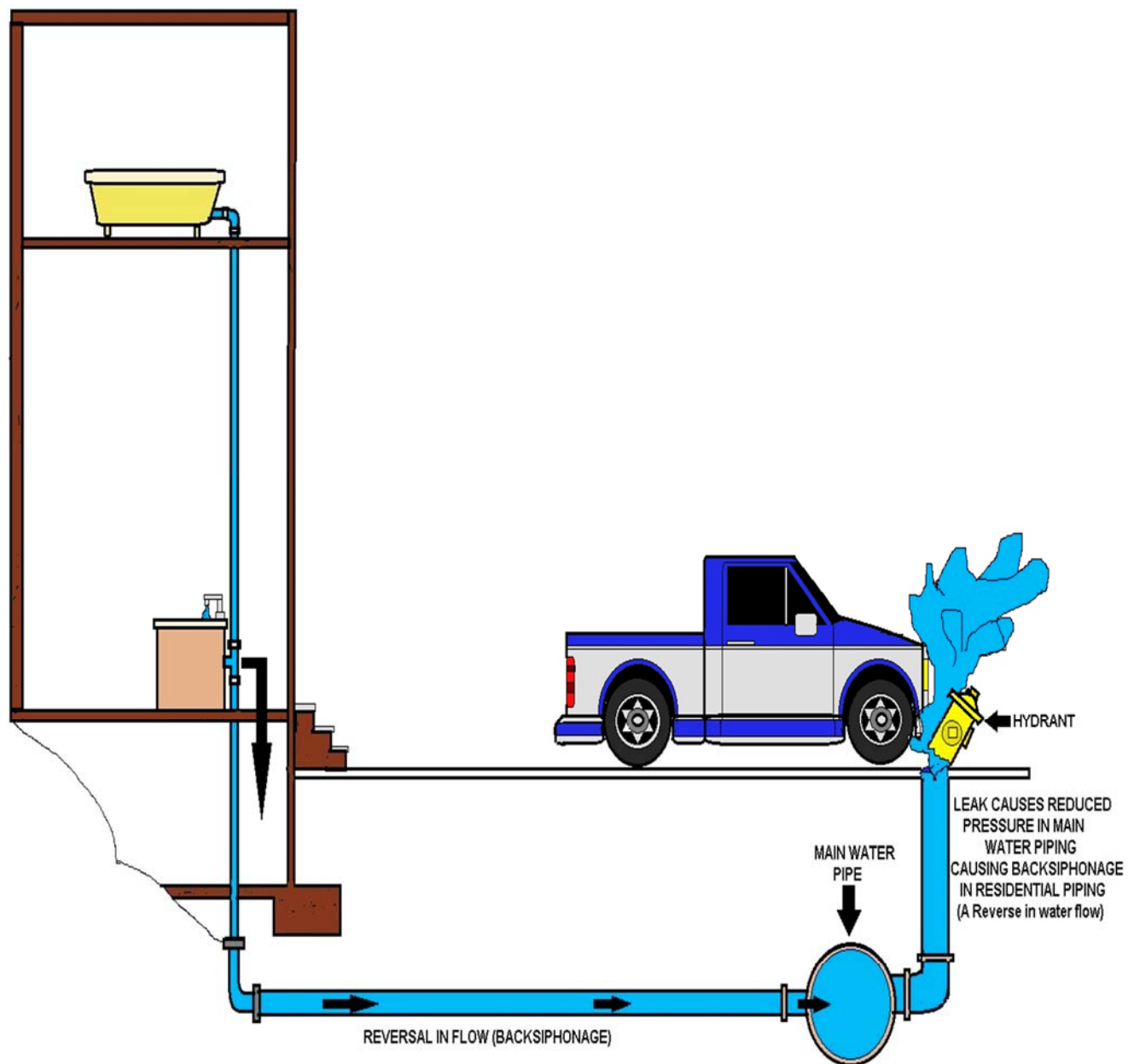

BACKSIPHONAGE

Backpressure

Backpressure backflow is backflow caused by a downstream pressure that is greater than the upstream or supply pressure in a public water system or consumer's potable water system. Backpressure (i.e., downstream pressure that is greater than the potable water supply pressure) can result from an increase in downstream pressure, a reduction in the potable water supply pressure, or a combination of both. Increases in downstream pressure can be created by pumps, temperature increases in boilers, etc.

Reductions in potable water supply pressure occur whenever the amount of water being used exceeds the amount of water being supplied, such as during water line flushing, firefighting, or breaks in water mains.

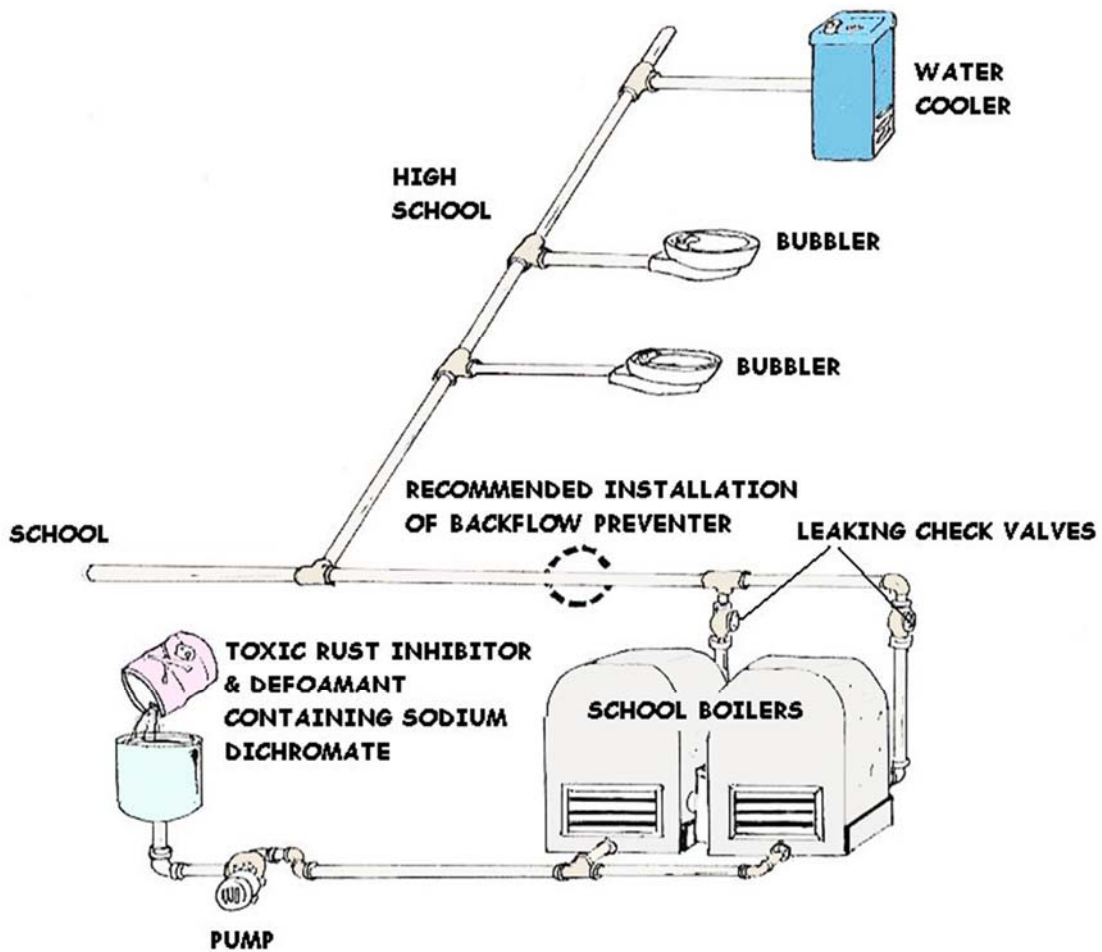

Backpressure example:

Booster pumps, pressure vessels

All backflow materials are used by permission from CMB Industries, Inc

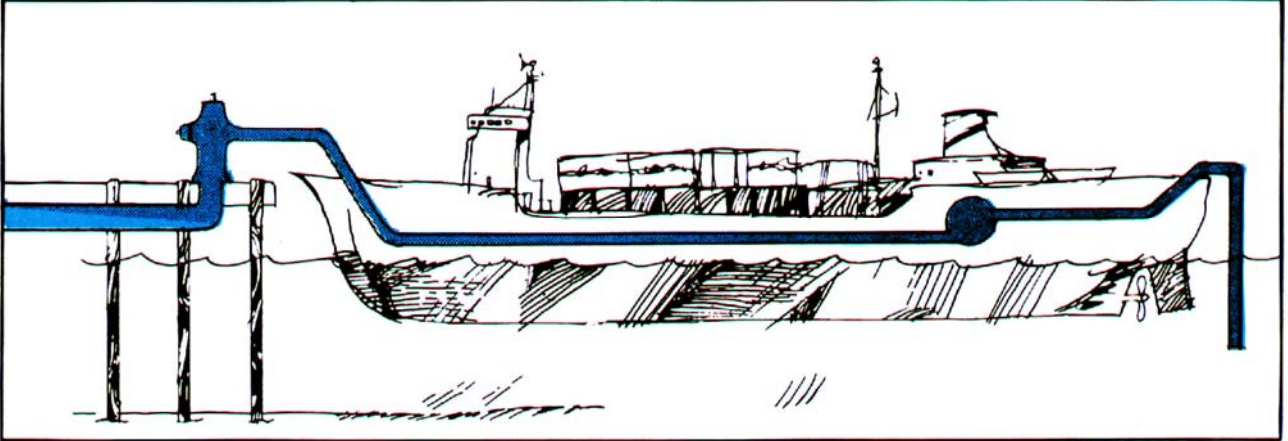

Backflow Responsibility

The Public Water Purveyor

The primary responsibility of the water purveyor is to develop and maintain a program to prevent or control contamination from water sources of lesser quality or other contamination sources from entering into the public water system.

Under the provisions of the Safe Drinking Water Act of 1974, (SDWA) and current Groundwater Protection rules the Federal Government through the EPA, (Environmental Protection Agency), national standards of safe drinking water. The separate states are responsible for the enforcement of these standards as well as the supervision of public water systems and the sources of drinking water.

The water purveyor (or supplier) is held responsible for compliance to the provisions of the Safe Drinking Water Act, to provide a warranty that water quality by their operation is in conformance with the EPA standards at the source, and is delivered to the customer without the quality being compromised as its delivery through the distribution system.

This is specified in the Code of Federal Regulations (Volume 40, Para. 141.2 Section c)”: Maximum contaminant level means the permissible level of a contaminant in water which is delivered to the free flowing outlet of the ultimate user of a public water system, except in the case of turbidity where the maximum permissible level is measured at the point of entry (POE) to the distribution system.

Contaminants added to the water under circumstances controlled by the user, except those resulting from corrosion of piping and plumbing caused by water quality, are excluded from this definition.

The Water Consumer

Has the responsibility to prevent contaminants from entering into the public water system by way of their individual plumbing system, and retain the expenses of installation, maintenance, and testing of the approved backflow prevention assemblies installed on their individual water service line.

The Certified General Backflow Tester

Has the responsibility to test, maintain, inspect, repair, and report/notify on approved backflow prevention assemblies as authorized by the persons that have jurisdiction over those assemblies.



Why do water suppliers need to control cross-connections and protect their public water systems against backflow?

Backflow into a public water system can pollute or contaminate the water in that system (i.e., backflow into a public water system can make the water in that system unusable or unsafe to drink), and each water supplier has a responsibility to provide water that is usable and safe to drink under all foreseeable circumstances.

Furthermore, consumers generally have absolute faith that water delivered to them through a public water system is always safe to drink. For these reasons, each water supplier must take reasonable precautions to protect its public water system against backflow.

What should water suppliers do to control cross-connections and protect their public water systems against backflow?

Water suppliers usually do not have the authority or capability to repeatedly inspect every consumer's premises for cross-connections and backflow protection. Alternatively, each water supplier should ensure that a proper backflow preventer is installed and maintained at the water service connection to each system or premises that poses a significant hazard to the public water system.

Generally, this would include the water service connection to each dedicated fire protection system or irrigation piping system and the water service connection to each of the following types of premises:

- (1) premises with an auxiliary or reclaimed water system;
- (2) industrial, medical, laboratory, marine or other facilities where objectionable substances are handled in a way that could cause pollution or contamination of the public water system;
- (3) premises exempt from the State Plumbing Code and premises where an internal backflow preventer required under the State Plumbing Code is not properly installed or maintained;
- (4) classified or restricted facilities; and
- (5) tall buildings.

Each water supplier should also ensure that a proper backflow preventer is installed and maintained at each water loading station owned or operated by the water supplier.

What is a backflow preventer?

A backflow preventer is a means or mechanism to prevent backflow. The basic means of preventing backflow is an air gap, which either eliminates a cross-connection or provides a barrier to backflow. The basic mechanism for preventing backflow is a mechanical backflow preventer, which provides a physical barrier to backflow.

The principal types of mechanical backflow preventer are the reduced-pressure principle assembly, the pressure vacuum breaker assembly, and the double check valve assembly. A secondary type of mechanical backflow preventer is the residential dual check valve.

Degrees of Hazards (HAZARD RATINGS)

High, or Contaminant

Low, or Pollutinal

CONTAINMENT PROTECTION *Secondary protection*

This approach utilizes a minimum of backflow devices and isolates the customer from the water main. It virtually insulates the customer from potentially contaminating or polluting the public water supply system.

Containment protection does not protect the customer within his own building, but it does effectively remove him from the possibility of public water supply contamination.

Containment protection is usually a backflow prevention device as close as possible to the customer's water meter and is often referred to as "Secondary Protection".

This type of backflow protection is excellent for water purveyors and is the least expense to the water customer, but does not protect the occupants of the building.

INTERNAL PROTECTION, *Primary protection*

The water purveyor may elect to protect his customers on a domestic internal protective basis and/or "fixture outlet protective basis"--in this case, cross-connection-control devices (backflow preventors) are placed at internal hazard locations and at all locations where cross-connections may exist including the "*last free flowing outlet.*"

This type of protection entails extensive cross-connection survey work usually performed by a plumbing inspector or a Cross-Connection Specialist.

In a large water supply system, internal protection in itself is virtually impossible to achieve and police due to the quantity of systems involved, the complexity of the plumbing systems inherent in many industrial sites, and the fact that many plumbing changes are made within commercial establishments that do not get the plumbing department's approval or require that the water department inspects when the work is completed.

Internal protection is the most expensive and best type of backflow protection for both the water purveyor and the customer alike, but is very difficult to maintain.

In order for the purveyor to provide maximum protection of the water distribution system, consideration should be given to requiring the owner of the premises to provide, at his own expense, adequate proof that his internal water supply system complies with the local or state plumbing code(s). In addition, he may be required to install, test, and/or maintain all backflow protection assemblies.

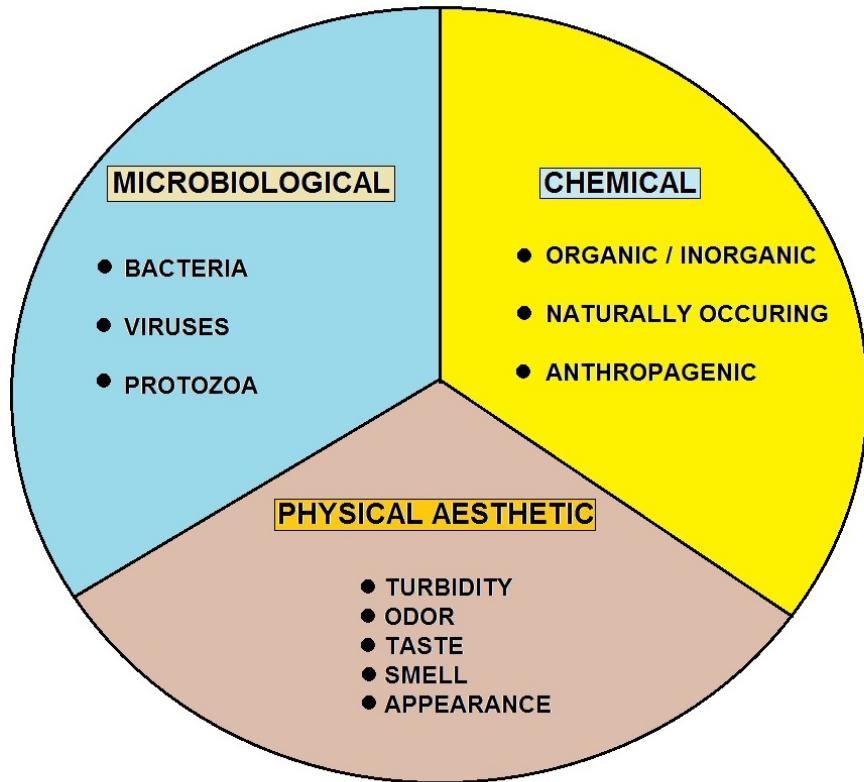

WATER QUALITY BROKEN DOWN INTO 3 BROAD CATEGORIES

Types of Backflow Prevention Methods and Assemblies

Approved Air Gap Separation (AG)

An approved air gap is a physical separation between the free flowing discharge end of a potable water supply pipeline, and the overflow rim of an open or non-pressure receiving vessel. These separations must be vertically orientated a distance of at least twice the inside diameter of the inlet pipe, but never less than one inch.

An obstruction around or near an air gap may restrict the flow of air into the outlet pipe and nullify the effectiveness of the air gap to prevent backsiphonage.

When the air flow is restricted, such as in the case of an air gap located near a wall, the air gap separation must be increased. Also, within a building where the air pressure is artificially increased above atmospheric, such as a sports stadium with a flexible roof kept in place by air blowers, the air gap separation must be increased.

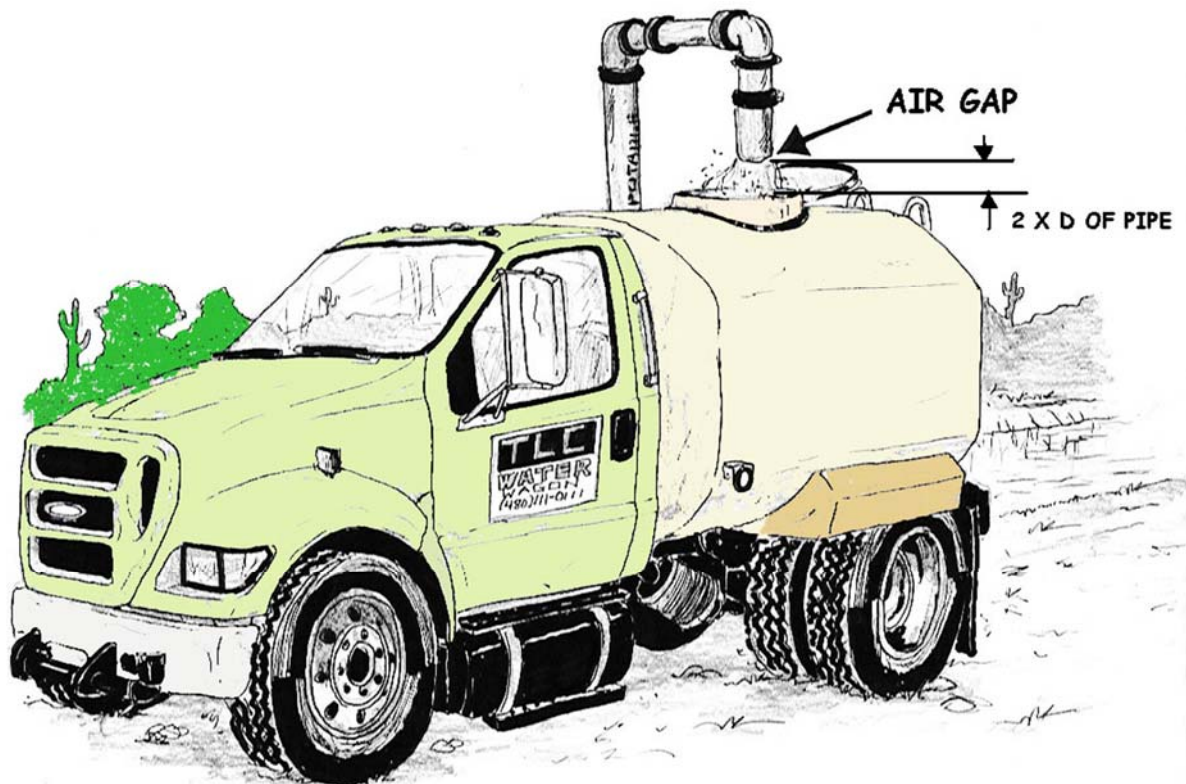

EXAMPLE OF AN AIR GAP



Which of these ice machine drains are approved air gaps?



Notice the larger pipe is an approved air gap, but what about the smaller drain in the rear?

Atmospheric Vacuum Breaker (AVB)

The Atmospheric Vacuum Breaker contains a float check (poppet), a check seat, and an air inlet port. The device allows air to enter the water line when the line pressure is reduced to a gauge pressure of zero or below. The air inlet valve is not internally loaded. To prevent the air inlet from sticking closed, the device must not be installed on the pressure side of a shutoff valve, or wherever it may be under constant pressure more than 12 hours during a 24 hour period.

Atmospheric vacuum breakers are designed only to prevent backflow caused by backsiphonage only from low health hazards.

Atmospheric Vacuum Breaker Uses: Irrigation systems, commercial dishwasher and laundry equipment, chemical tanks and laboratory sinks (backsiphonage only, non-pressurized connections)

(Note: hazard relates to the water purveyor's risk assessment; plumbing codes may allow AVB for high hazard fixture isolation).

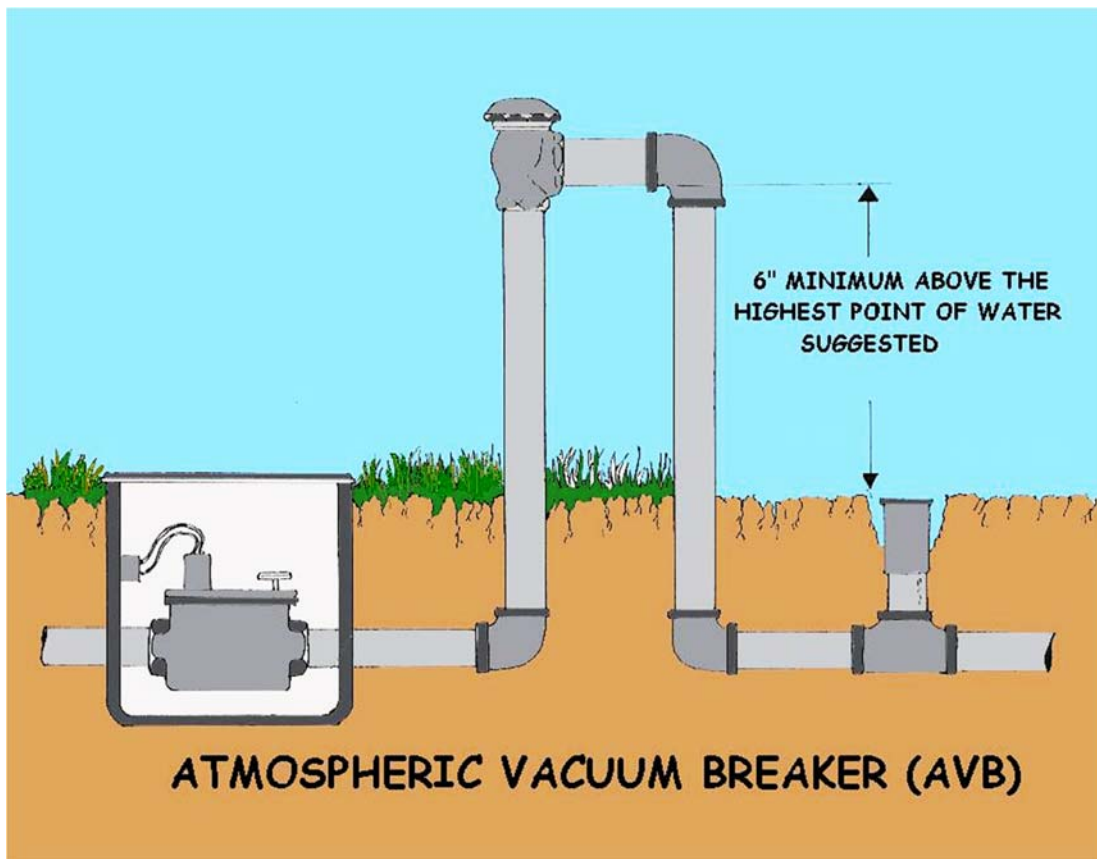

All backflow materials are used by permission from CMB Industries, Inc

Pressure Vacuum Breaker Assembly (PVB)

The Pressure Vacuum Breaker Assembly consists of a spring loaded check valve, an independently operating air inlet valve, two resilient seated shutoff valves, and two properly located resilient seated test cocks. It shall be installed as a unit as shipped by the manufacturer. The air inlet valve is internally loaded to the open position, normally by means of a spring, allowing installation of the assembly on the pressure side of a shutoff valve.

PRESSURE VACUUM BREAKER ASSEMBLY

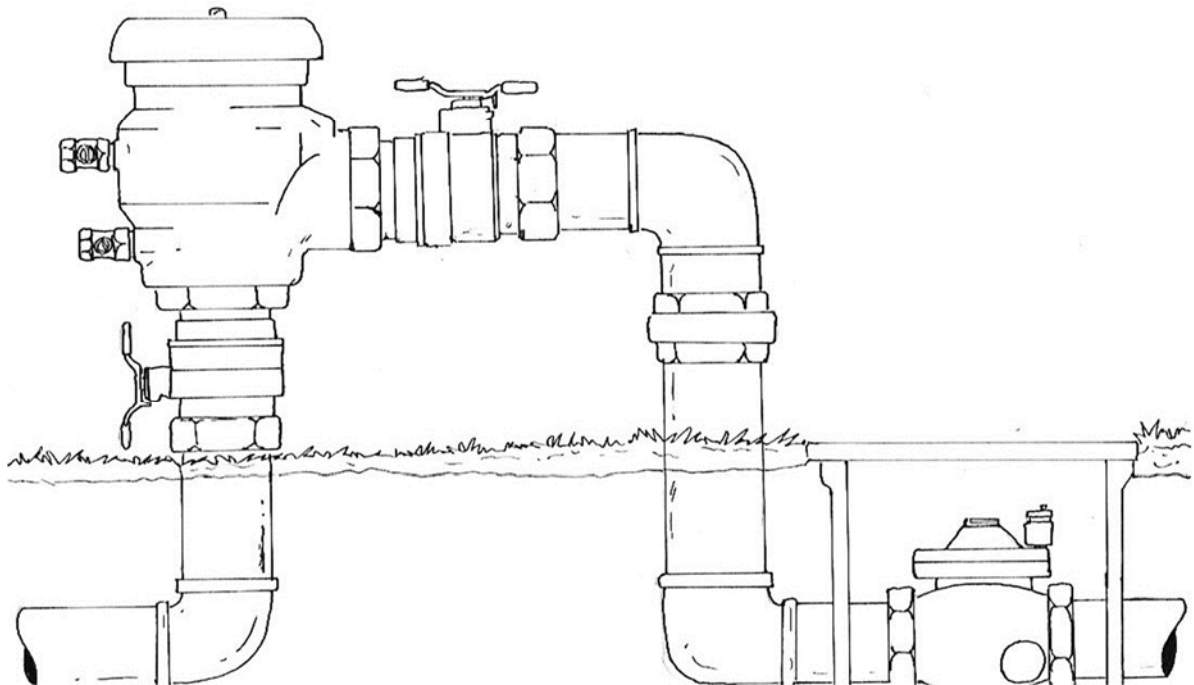

All backflow materials are used by permission from CMB Industries, Inc.

Double Check Valve Assembly (DC)

The Double Check Valve Assembly consists of two internally loaded check valves, either spring loaded or internally weighted, two resilient seated full ported shutoff valves, and four properly located resilient seated test cocks.

This assembly shall be installed as a unit as shipped by the manufacturer. The double check valve assembly is designed to prevent backflow caused by backpressure and backsiphonage from low health hazards.

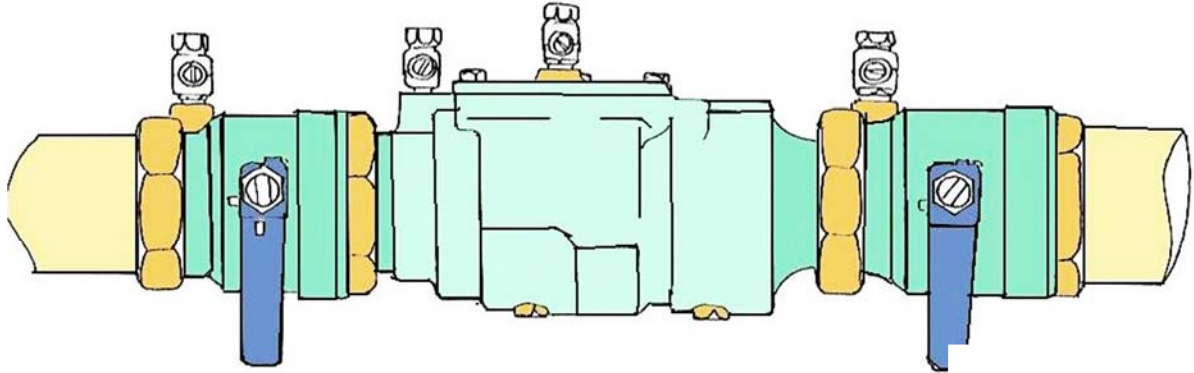

DOUBLE CHECK VALVE ASSEMBLY

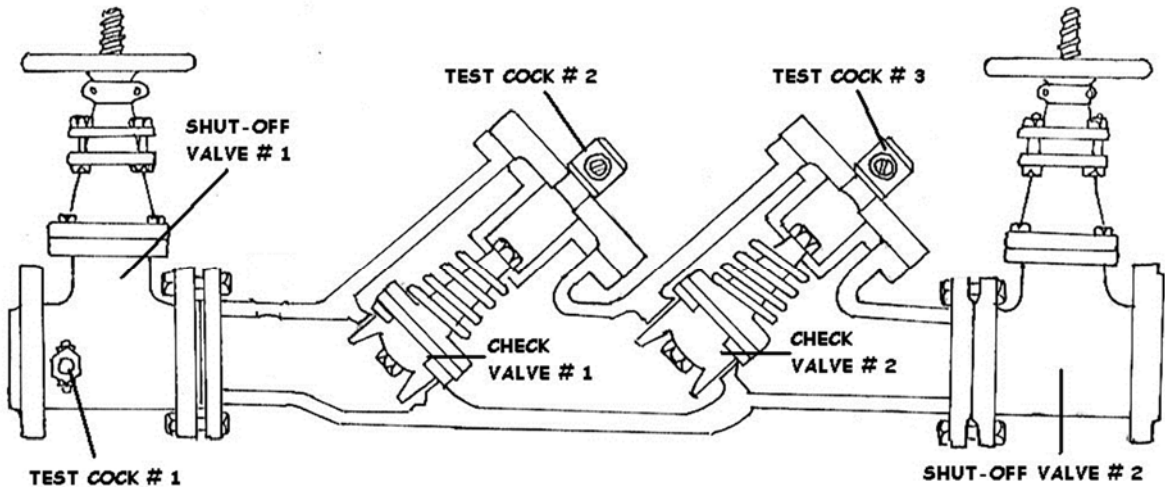

DOUBLE-CHECK BACKFLOW ASSEMBLY

Reduced Pressure Backflow Assembly (RP)

The reduced pressure backflow assembly consists of two independently acting spring loaded check valves separated by a spring loaded differential pressure relief valve, two resilient seated full ported shutoff valves, and four properly located resilient seated test cocks. This assembly shall be installed as a unit shipped by the manufacturer.

During normal operation, the pressure between the two check valves, referred to as the zone of reduced pressure, is maintained at a lower pressure than the supply pressure. If either check valve leaks, the differential pressure relief valve maintains a differential pressure of at least two (2) psi between the supply pressure and the zone between the two check valves by discharging water to atmosphere.

The reduced pressure backflow assembly is designed to prevent backflow caused by backpressure and backsiphonage from low to high health hazards.

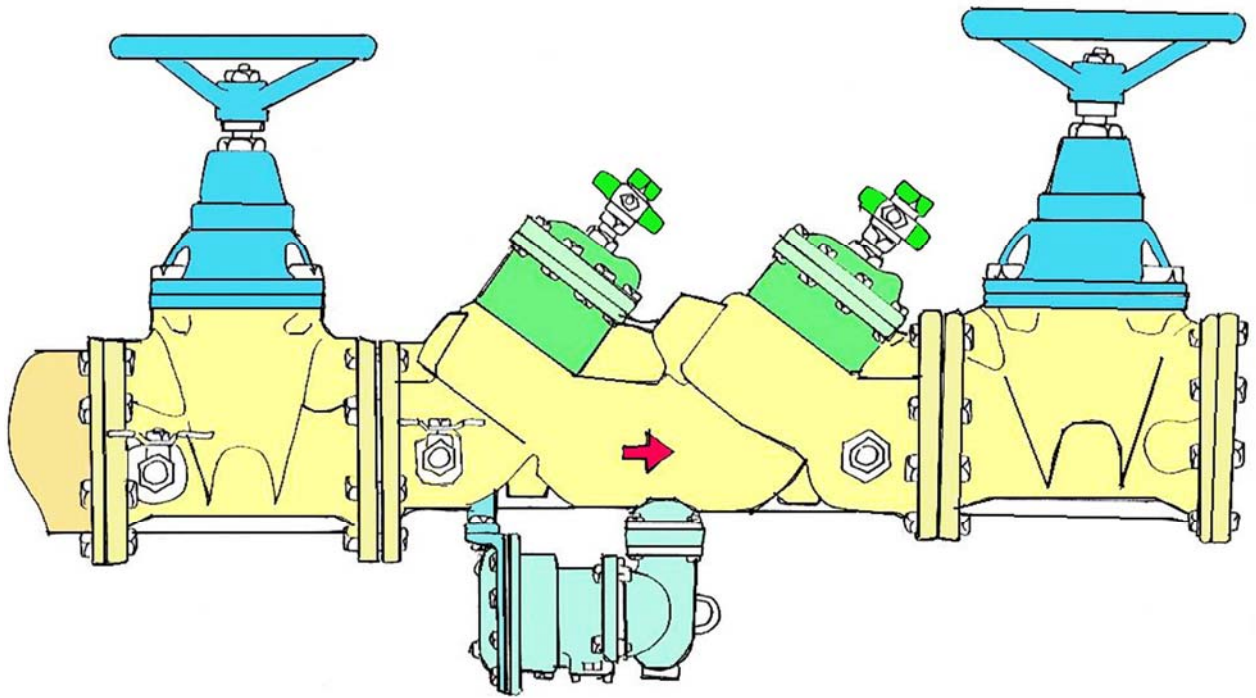

REDUCED PRESSURE BACKFLOW ASSEMBLY

Typical RP Installation

Some Water Purveyors will require the assembly to be a minimum of 12 inches between the bottom of the discharge port and the surface or ground level.

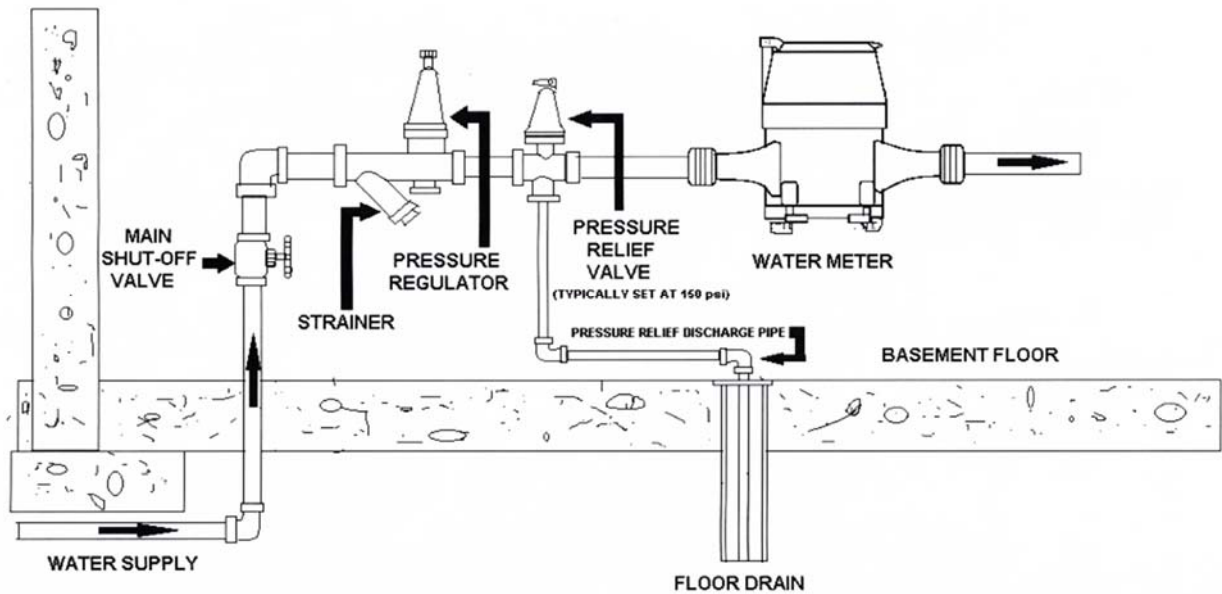
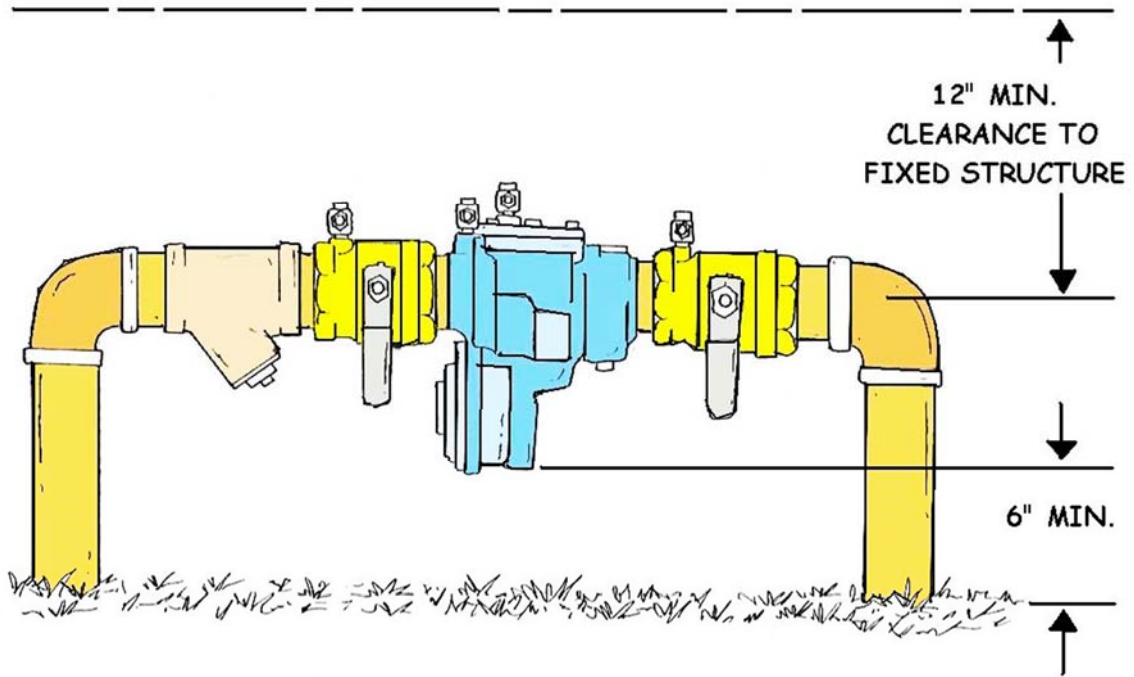

RP Manifold Installation

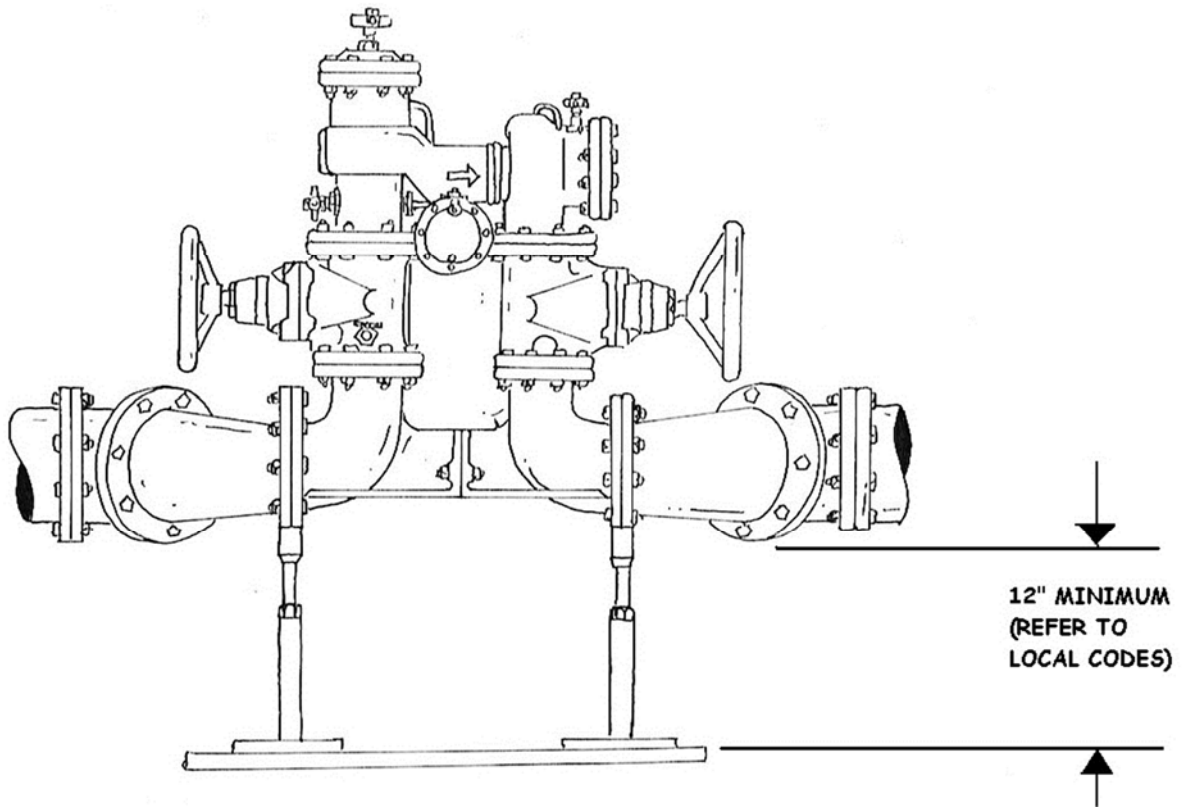

Why do Backflow Preventors have to be Tested periodically?

Mechanical backflow preventors have internal seals, springs, and moving parts that are subject to fouling, wear, or fatigue. Also, mechanical backflow preventors and air gaps can be bypassed. Therefore, all backflow preventors have to be tested periodically to ensure that they are functioning properly. A visual check of air gaps is sufficient, but mechanical backflow preventors have to be tested with properly calibrated gauge equipment.

Backflow prevention devices must be tested annually to ensure that they work properly. It is usually the responsibility of the property owner to have this test done and to make sure that a copy of the test report is sent to the Public Works Department or Water Purveyor.

If a device is not tested annually, Public Works or the Water Purveyor will notify the property owner, asking them to comply. If the property owner does not voluntarily test their device, the City may be forced to turn off water service to that property. State law requires the City to discontinue water service until testing is complete.



Leaky RP, probably has some debris in the pressure differential area or in the hydraulic relief valve area.



If you ever need to prove for a need for backflow protection, visit your local fair grounds or trailer park. I guarantee that you'll find all the cross-connections you need at the concession stand and most health departments and plumbing officials could care less. Here is a photograph of a drinking water and sewer connection in the same meter box with the sewer backing up. The white hose is for drinking water and it is back siphoning the sewage water, the sheen is a reflection of the water pulsating in and out of the meter box.

What is backflow? *Reverse flow condition.*

Backflow is the undesirable reversal of flow of nonpotable water or other substances through a cross-connection and into the piping of a public water system or consumer's potable water system. There are two types of backflow--***backpressure*** and ***backsiphonage***.

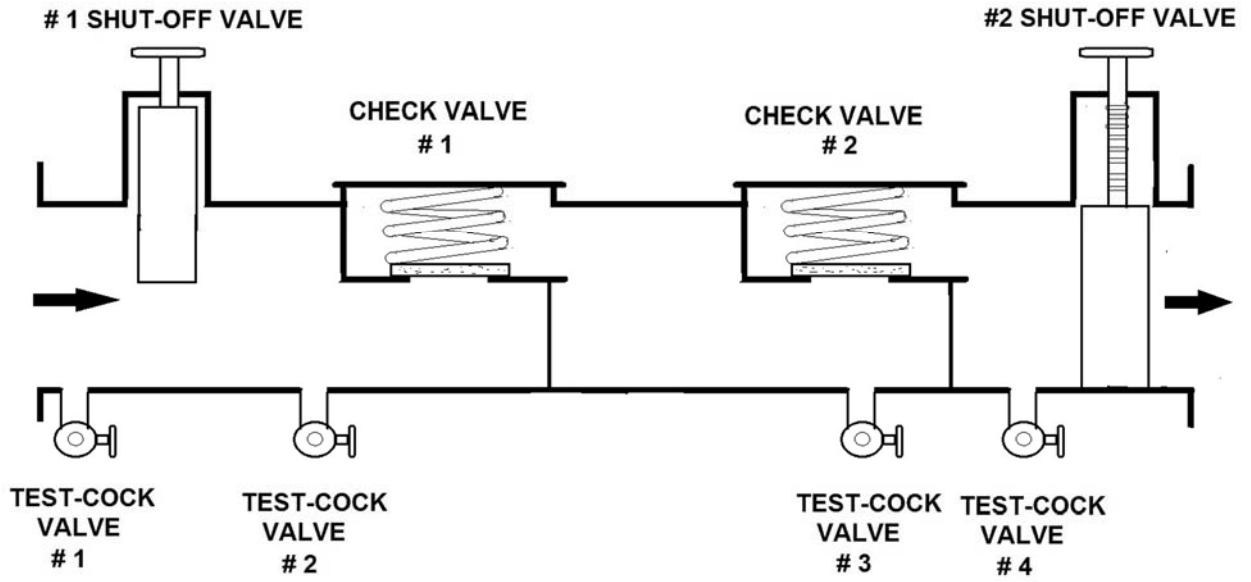

DOUBLE - CHECK VALVE

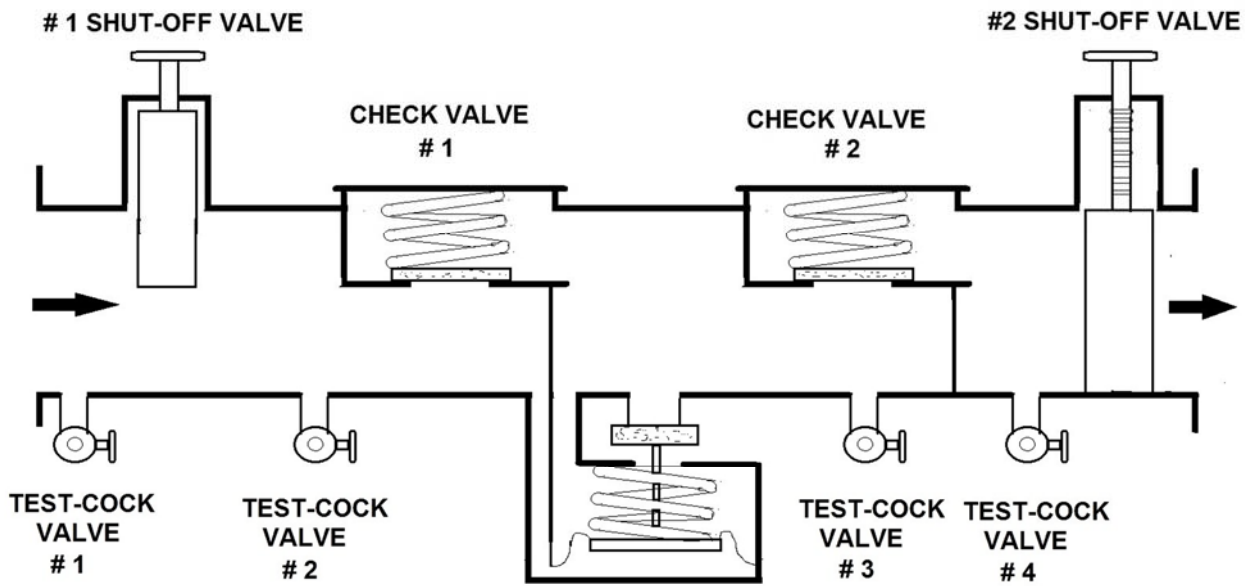

REDUCED PRESSURE ASSEMBLY

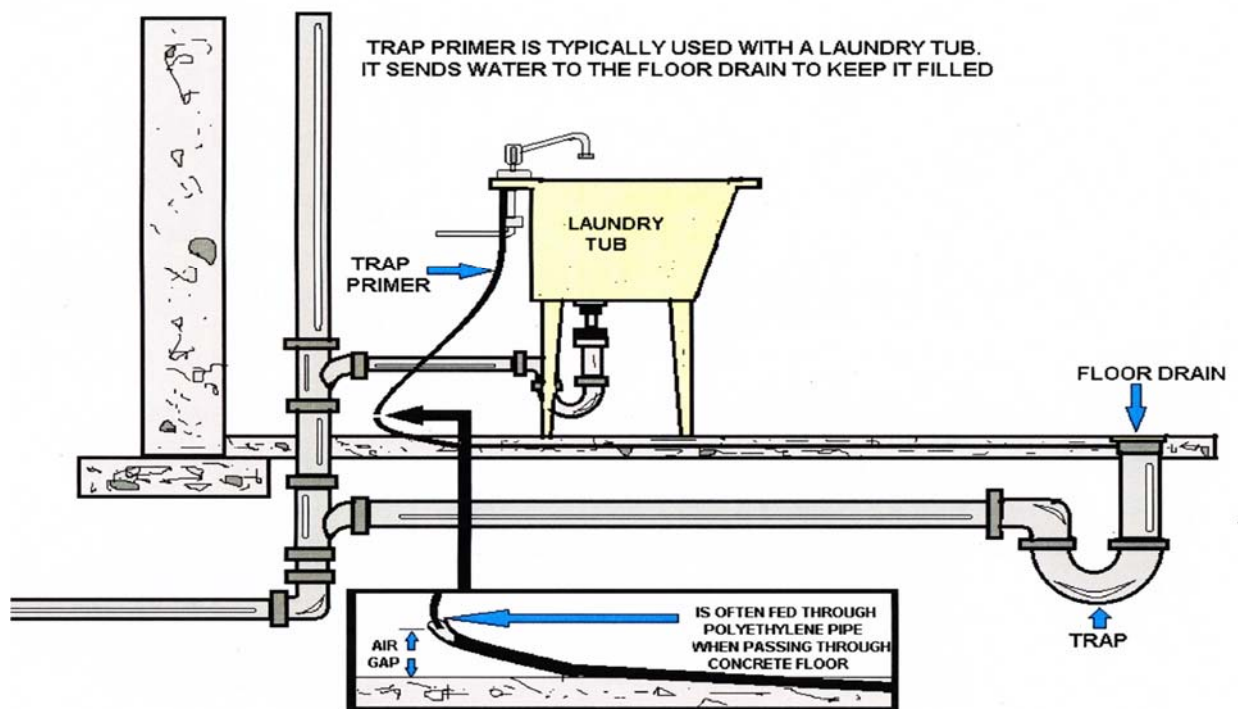
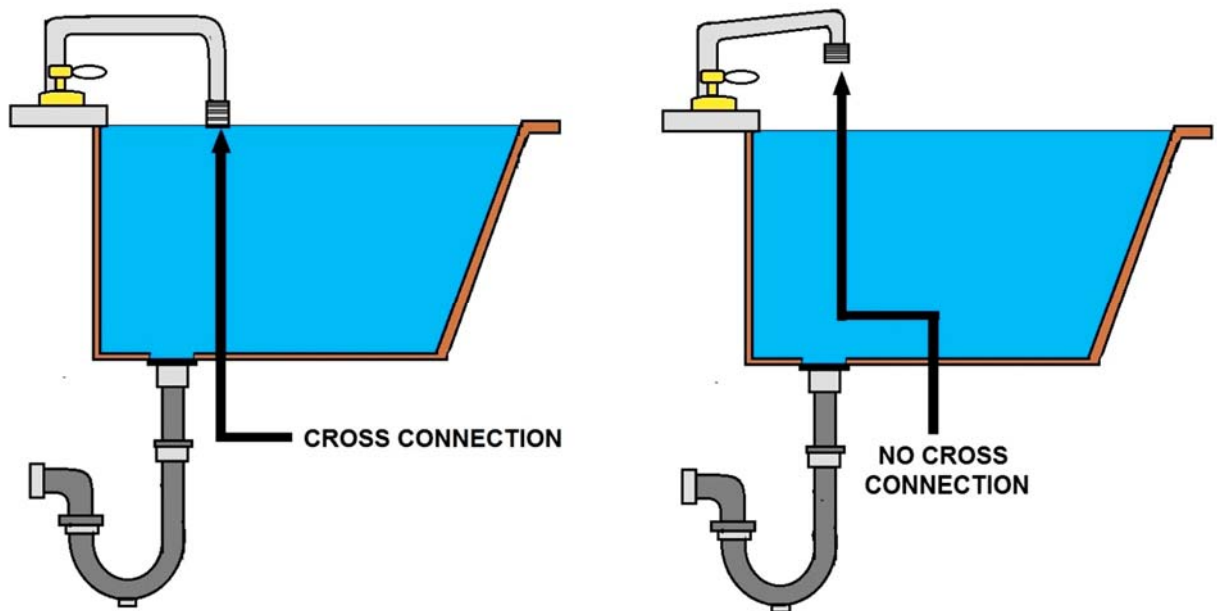

TRAP PRIMER

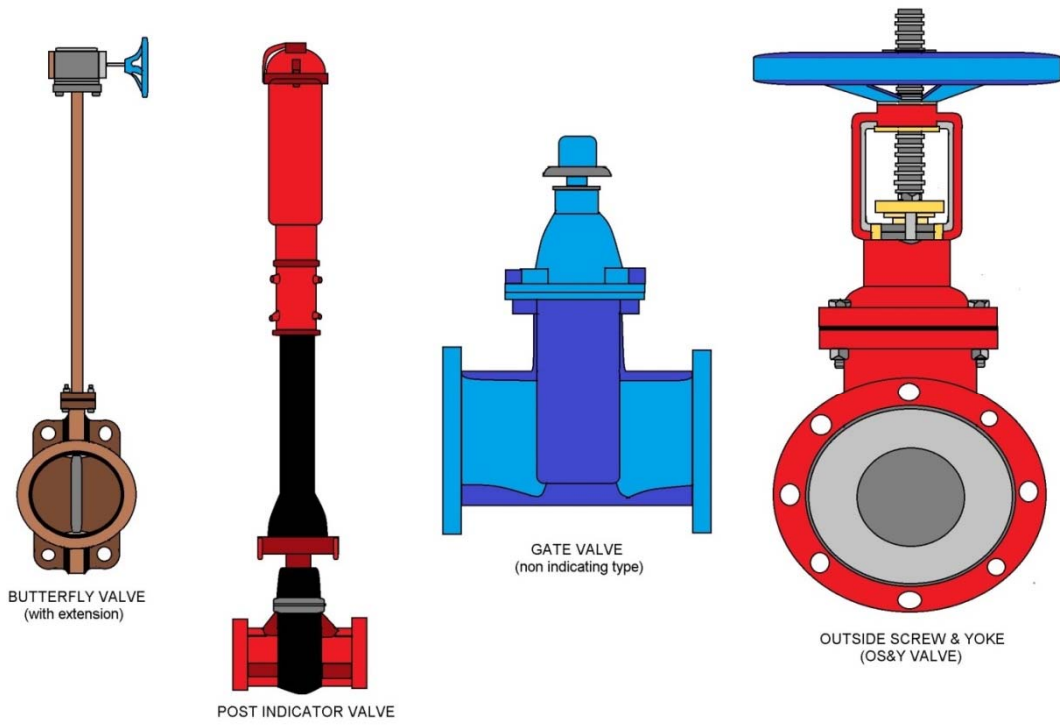

TYPES OF VALVES

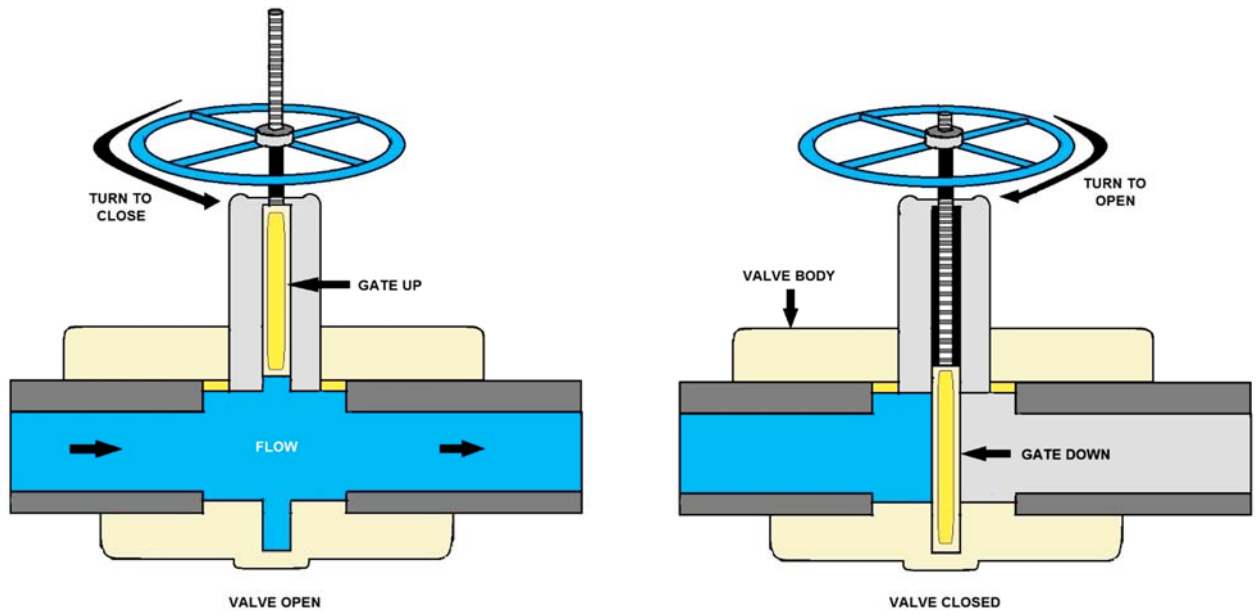

OS&Y VALVE

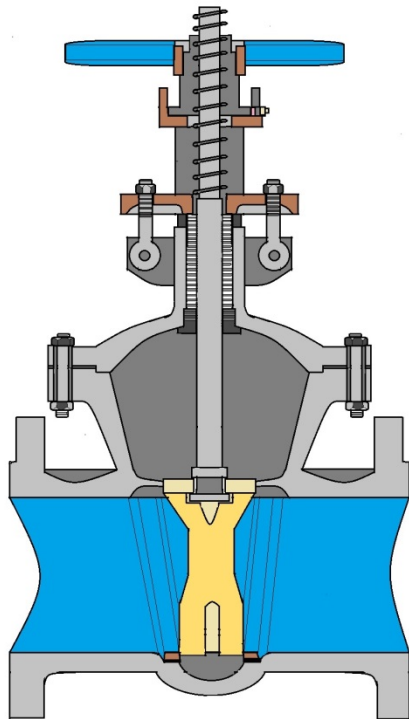

OS&Y VALVE

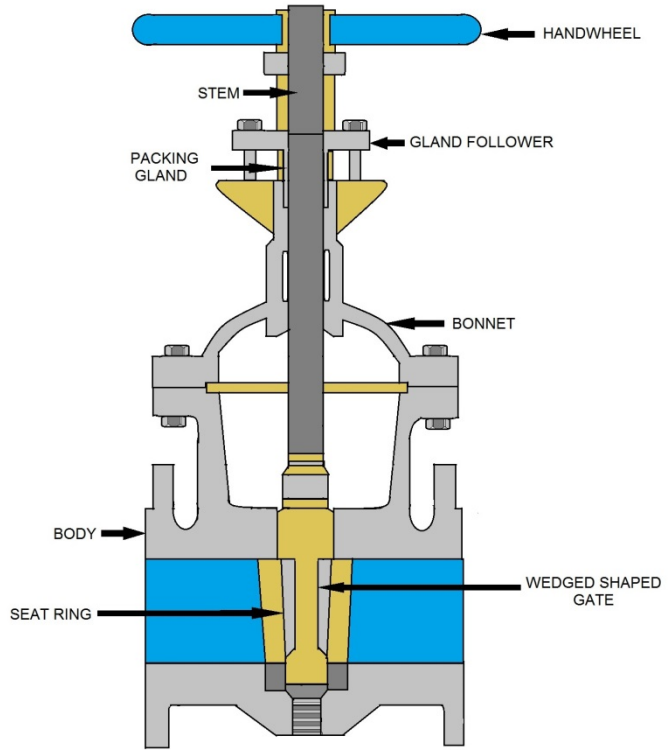

VALVE PARTS

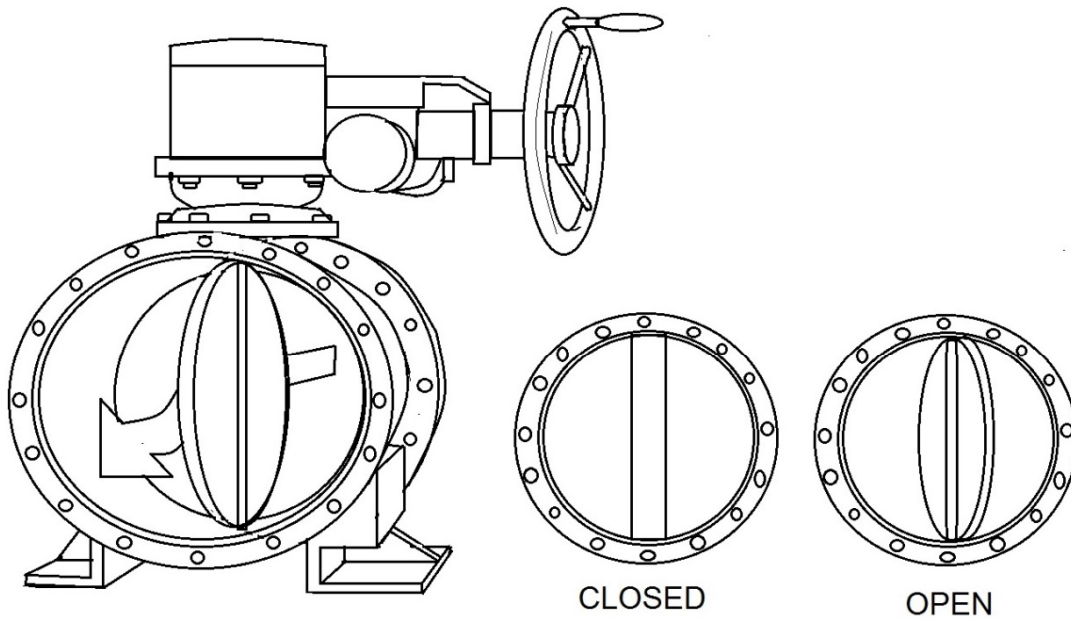

BUTTERFLY VALVE

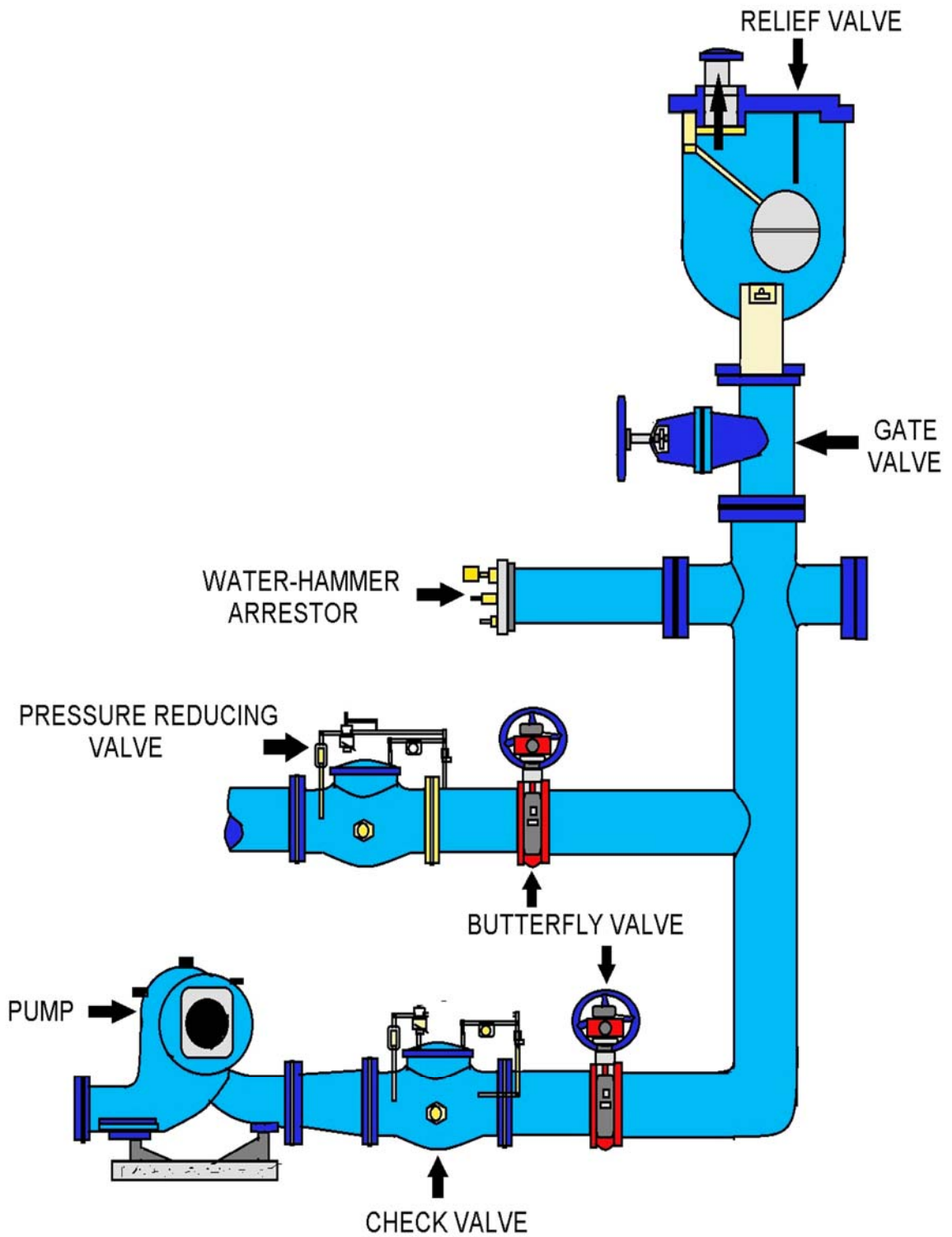

AIR RELIEF VALVE INSTALLATION

43

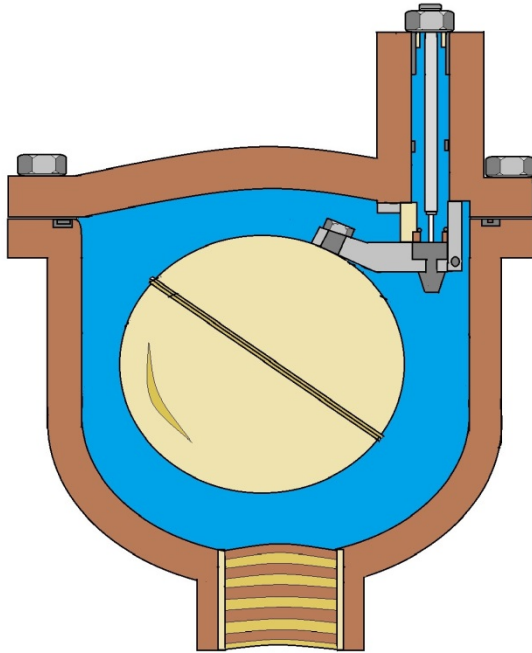

AIR RELIEF VALVE

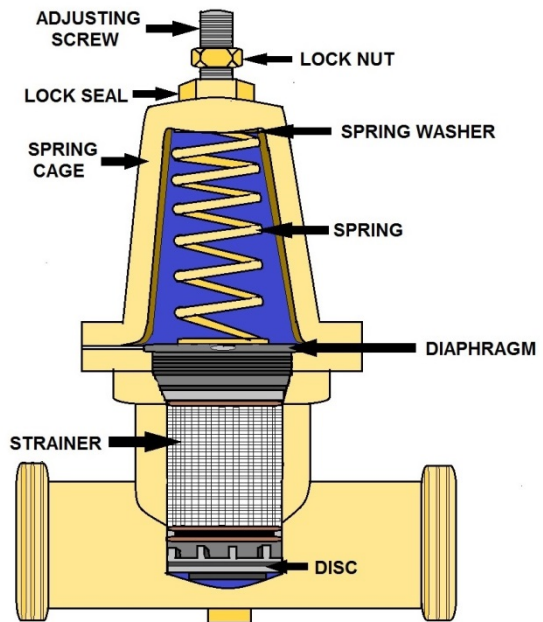

PRESSURE REDUCING VALVE

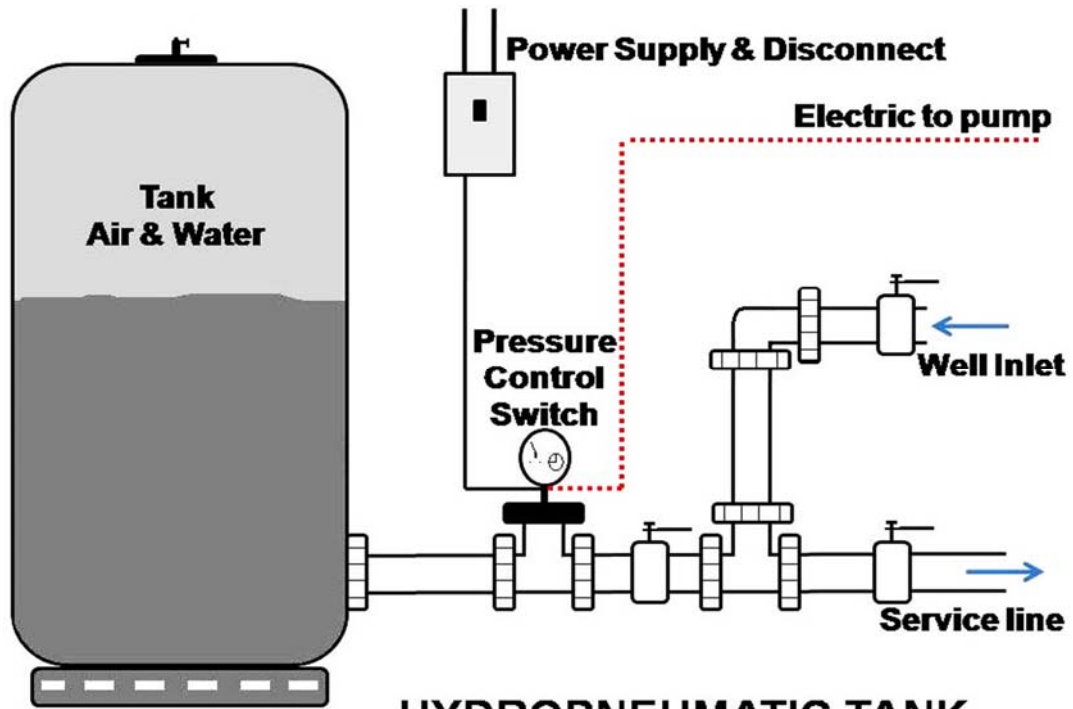

HYDROPNEUMATIC TANK

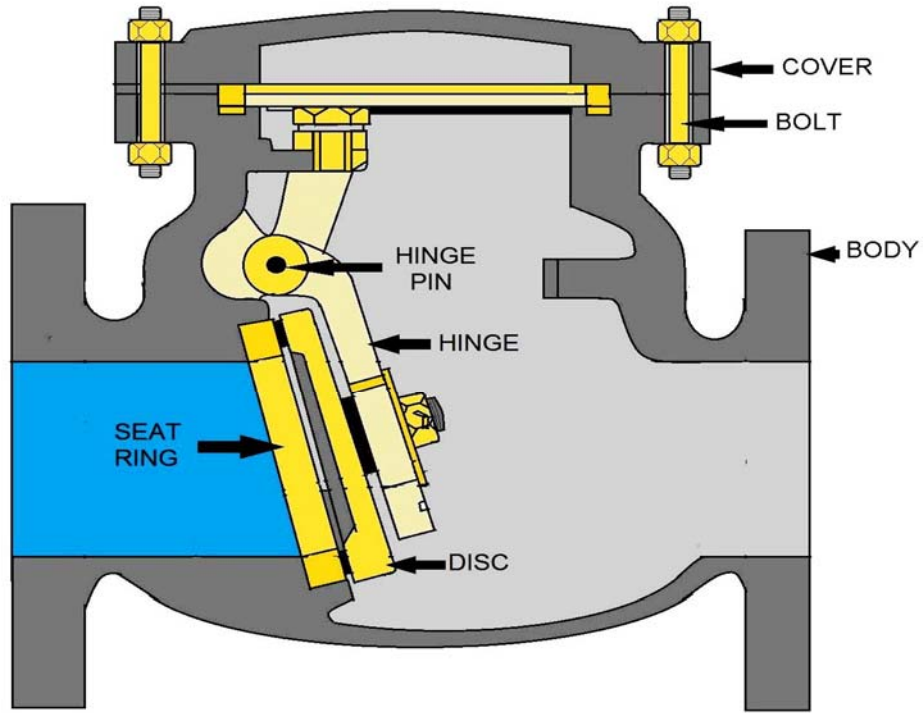

CHECK VALVE

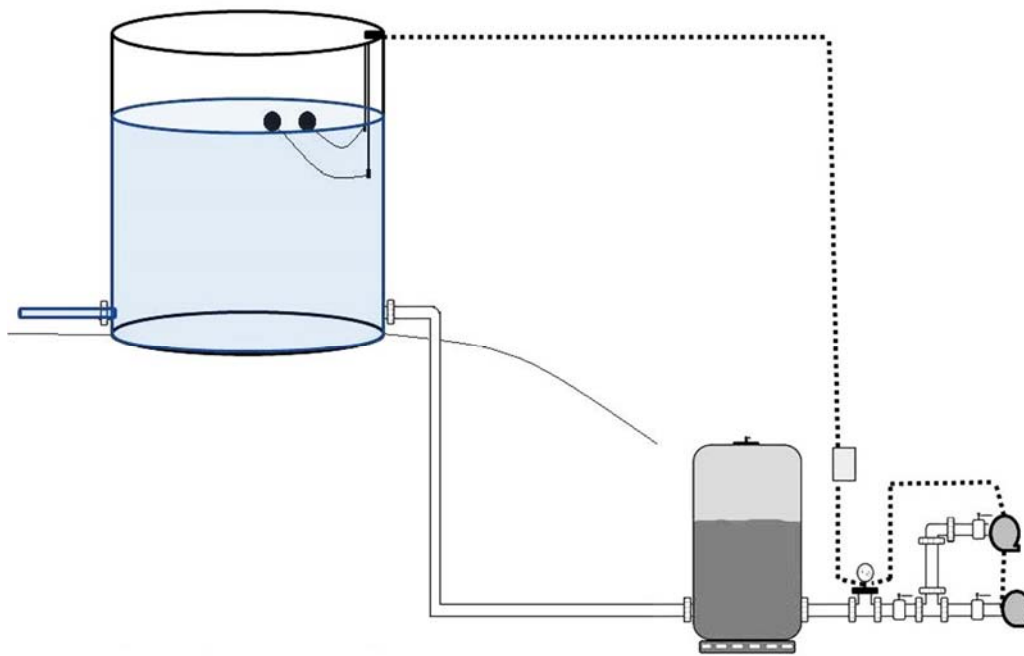

HYDROPNEUMATIC & STORAGE TANK

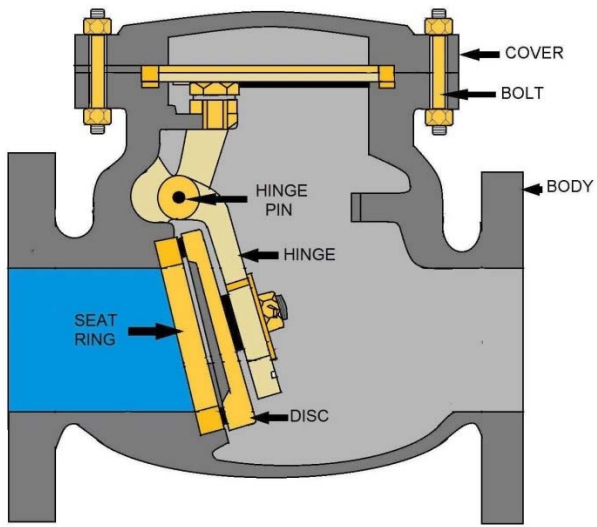

CHECK VALVE

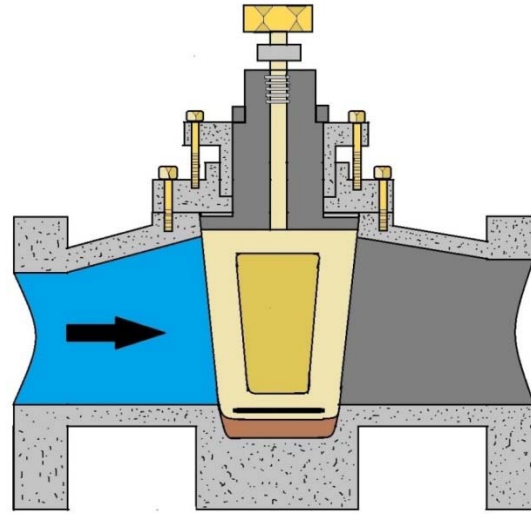

PLUG VALVE

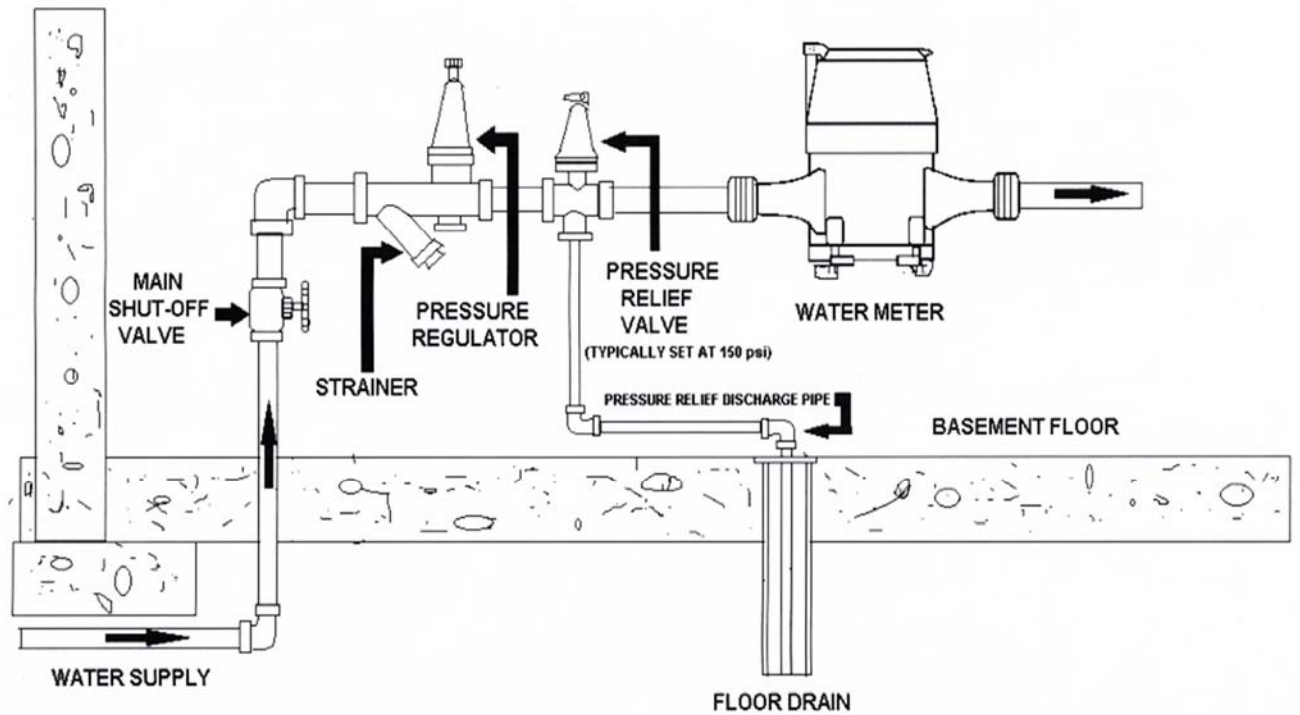

Plumbing Codes

The Plumbing Code

The Code outlines the best and most modern methods to be used in plumbing installations. Since the plumbing in any private or public building is a part of the community water and sewage disposal system, it is vital that such installations should not be left to the discretion of irresponsible individuals. The protection of the public health and safety must be maintained by the establishment of sound code provisions. A plumbing or sanitation code is not a plumber's code. It is rather a set of Rules and Regulations imposed by cities, counties and states on anyone who undertakes any work involving the installation of drinking water, sewer or toilet facilities in homes, offices, factories, schools and hospitals. Regardless of who might do the work, plumbing and sanitation codes require that it be done in a specific, safe manner because it was found that failure to do so caused widespread disease, which can be crippling and deadly-to the community.

Licensing

Plumbers must demonstrate their competence as installers of plumbing systems to an official executing board prior to being issued a license. A plumbing code which is technically perfect is valueless if its provisions are not observed and enforced. The issuance of a license by a community specifies that the license holder is qualified both theoretically and practically and that their technical knowledge is sufficient to maintain the standards of the code.



Building Permit Counter

Inspection and Permits

Through the issuance of permits and the requirements of public inspection, a community can assure itself of proper plumbing code enforcement. The permit allows the plumbing inspector to protect the consumer by assuring plumbing installations are done properly. The inspection of such plumbing work insures that the installation is being completed in accordance with code provisions.

It Pays to Take Care of Our Plumbing

The average household plumbing system represents an investment of about fifteen percent of the value of the house. No part of the house is more important. Nothing in the house is used more often. A smoothly functioning plumbing system is a pin to health and adds to the convenience of modern living.

There are many things that an owner or renter can do; there are many things that should be left to an expert-the plumbing contractor and his staff of journeymen plumbers. Minor repairs should be made promptly. Annoyances such as a clogged drain, dripping faucet or a leaking flush valve in the toilet, are more than a mere bother - they usually waste money. This booklet suggests remedies for these and many other household plumbing problems.

Major repairs, replacements, and new plumbing installations should be left to the supervision of a plumbing contractor. His working methods are based on years of experience - and his guarantee is assurance that all materials and methods are of the highest quality.

For homeowners only:

The permit issued to a homeowner is an authorization for the homeowner to do the plumbing work or to receive assistance from a friend, neighbor, relative or other person when none of the individuals doing such plumbing hold themselves out as engaged in the trade or business of plumbing. In general terms, if you are being authorized by the property owner to apply for the plumbing permit, your signature on the permit application signifies that you have such authorization from the owner of the property. If a professional plumber is contracted with, they must be a registered contractor. Always check with your local administrative authority or development services for more information.

Generally speaking, whenever you are going to install, relocate or change a plumbing system you will need a plumbing permit.

How the plumbing inspectors can help the homeowner

Plumbing inspections ensure that water systems in buildings are connected properly, with no cross-connection to contaminate potable water systems. Fixtures must be properly trapped, to prevent sewer gas from escaping into a buildings. Hot water heaters are also inspected to make sure that they have been installed properly, to prevent an explosion.

Once you have obtained the plumbing permit, you have the option to submit an industry standard drawing (isometric or elevation) of the plumbing system you want to install in your home. Always check with your local administrative authority or development services for more information.

This drawing should include:

- ✓ the type of material (copper, ABS, etc.) to be used;
- ✓ the size of each section of piping;
- ✓ the type of each fitting to be used in the waste and vent system; and
- ✓ the sizing of each section of piping for both the hot and the cold distribution lines.

Step 1. Test the plumbing system for leaks.

Test the drain, waste and vent systems and the water distribution system. The inspector neither performs nor provides the means for conducting the test of the plumbing system.

To test the drain, waste and vent system, make sure that all pipes and fittings are properly glued. Plug all openings tightly and look the system over carefully to make sure all is ready for the test. Fill the system with water to the roof (or at least 10-feet high for a groundwork) and check the entire system for leaks.

To test the water distribution system, make sure the system is completed and ready to hold pressure. Connect the system to the water source of the building so that the system will be tested with the water pressure that will exist in the system under normal operating conditions. Check the entire system for leaks.

The drain, waste and vent system and the water distribution system must be under test and not showing any sign of leakage at the time of inspection.

Step 2. The "groundwork" inspection.

Plumbing systems installed below ground, such as under a concrete floor that needs to be poured before continuing construction, must be tested and inspected prior to cover. Call the inspection line to request a groundwork inspection. Do not cover any of the pipes before the inspector approves the work.

Step 3. The "rough-in" inspection.

This will be an inspection of the entire plumbing system that will be concealed within the construction of the walls, floors or ceilings. Call the inspection request line to request a rough-in inspection. Again, the inspector needs to see all of the system, so do not cover any part of the system prior to inspection.

Note: This inspection must be completed and approved prior to contacting the building inspector for your framing inspection.

Step 4. The "final" inspection.

When the fixtures are installed and operational, you must call the inspection request line and request a final inspection. Although the system will be operational, remember that the system is not approved for normal use until final approval.

Note: This inspection must be completed and approved prior to contacting the building inspector for your final building/occupancy inspection. Always check with your local administrative authority or development services for more information.

Where and How to Shut-Off Water

Knowing where and how to shut off water for the entire house or any part of it can be mighty important in an emergency. That's why it is extremely important for all members of the family to know where the valves are and in which direction they should be turned to shut off the water.

One way to identify the valves is to have a tag on each valve indicating its function, that is, which fixtures or group of fixtures it controls. Valve identifying tags may be obtained from plumbing dealers. Many plumbers are glad to offer a valve tagging service to their customers or prospective customers.

Another method of identification is by means of a valve chart. Because this is somewhat more elaborate, it is usually employed only for houses with several bathrooms. A drawing is made of the basement piping with all the valves indicated. The valves are numbered on the chart and tags with corresponding numbers are placed on the valves. Still another idea which aids in identification is to paint pipes a distinctive color.

Obviously, the most important valve in the house is the main shut-off valve for the entire plumbing system. This valve, generally located on the house side or service of the water meter, usually has a handle like a wheel. If it has not been used in many years, it may require a wrench to turn it. Because the easy operation of this valve in case of emergency is so important, it is advisable to place a few drops of oil around the valve handle once or twice a year. This will prevent the sticking action of corrosion.

The shut-off valve may be the ground-key type with a small hole bored in its side for draining the pipes after the water is shut off, or it may be a drain and stop with a cap nut covering the drain opening. In either case, close the opening before turning the water off. Unless this is done, water will spurt with force.

Where no means has been provided for shutting off a drain opening, drive a small wooden peg into it until the pressure is relieved by draining the piping that is exposed.

In addition to the main shut-off valve at the meter, the well plumbed house has individual shut-off valves on the branch lines leading to individual fixtures, groups of fixtures or equipment such as water heaters, water softeners, automatic washers, etc. Many contractors, when installing plumbing fixtures, provide separate shut-off valves or stops for each individual fixture. These will be found on the supply lines below the fixture. These individual stops are a great convenience to regulate water flow in case of repairs as well as emergencies.



Quality of Water Supply

All premises intended for human habitation or occupancy shall be provided with a potable water supply. The potable water supply shall not be connected to non-potable water and shall be protected from backflow and backsiphonage.

Color Code

Identification of piping. All piping conveying non-potable water shall be permanently identified by a distinctive yellow-colored paint so that such piping is readily distinguishable from piping carrying potable water.

Protection of Potable Water

a) Cross Connection (Submergence). Potable water supply piping and water discharge outlets shall not be submerged in any sewage or toxic substance. Where potable water supply piping or water discharge outlets are submerged in other substances, they shall be provided with backflow protection.

b) Approval of Devices and Maintenance. All reduced pressure principle (RP), reduced pressure detector (RPDA), double check (DCA) and double check detector (DCDA) backflow prevention assemblies shall be tested and approved by a Cross-Connection Control Device Inspector (CCCDI) before initial operation, and at least annually thereafter. Records to verify testing and maintenance shall be available at the site of the installation.

c) Backflow. The water distribution system shall be protected against backflow. Each water outlet shall be protected from backflow by having the outlet end from which the water flows spaced a distance above the flood-level rim of the receptacle into which the water flows sufficient to provide a minimum fixed air gap. Where it is not possible to provide a minimum fixed air gap, the water outlet shall be equipped with an accessible backflow prevention device or assembly.

d) Fire Safety Systems. The installation of any fire safety system involving the potable water supply system shall be protected against backflow as follows:

1) Backflow protection is not required for fire safety systems constructed as follows:

A) The system shall be looped, with no dead ends, to allow circulation, to prevent the stagnation of water in the line;

B) The system shall not have any non-potable connections, or a fire department hose (Siamese) connection;

C) The system shall have 20 sprinkler heads or less; and

2) A double detector check valve or double check valve backflow preventer assembly shall be installed at the fire safety system's point of connection to the potable water supply when a fire safety system has no chemical additives or non-potable connection, but has one or more fire department hose connections (for boosting pressure and flow to the fire safety system) that are served only by fire-fighting apparatus connected to a public water

supply or a fire department that does not use chemical additives or rely upon any non-potable water supply.

3) A fixed air gap with a break tank or other storage vessel or a reduced pressure principle backflow preventer assembly (RPZ) shall be installed at the fire safety system's point of connection to the potable water supply when:

A) The fire safety system contains additives such as antifreeze, fire retardant or other chemicals. (The RPZ may be located at the point of connection to that section of the system containing such additives when the system's connection to the water supply is protected by a double detector check valve backflow preventer assembly); or

B) Non-potable water flows into the fire safety system by gravity; or

C) There is a permanent or emergency connection whereby water can be pumped into the fire safety system from any other non-potable source; or

D) Fire department connections are available that could permit water to be pumped into the fire safety system from a non-potable source capable of serving the fire safety system. (A non-potable source of water shall be considered capable of serving the fire safety system under the following conditions: It must be capable of year-round use, maintained with at least 50,000 gallons of usable water not subject to freezing, accessible to firefighting pumper equipment, and located within 1,700 feet of the facility.)

e) Prohibited Connections.

1) Sewage Lines. There shall be no direct connection between potable water lines and lines, equipment and vessels containing sewage. Such connections shall be made only through a minimum fixed air gap as outlined in Section 890.1140(a).

2) Chemical or Petroleum Pressure Vessels. There shall be no direct connection between any potable water supply and any pressure vessel, i.e., storage tank, tank car, tank truck or trailer or other miscellaneous pressurized tank or cylinder containing or having contained liquefied gaseous petroleum products or other liquefied gaseous chemicals. Where it is necessary to discharge from a potable water line to such a vessel, such discharge shall be through a minimum fixed air gap. Exception: Chemical pressure vessels containing chemicals used in the water treatment process, for uses other than private purposes, are exempt from the provisions of this subsection.

3) If water under pressure is required, as in subsections (e)(1) and (2) of this Section, it shall be supplied by means of an auxiliary pump taking suction from a tank provided for this purpose only with an over rim supply having the required minimum fixed air gap.

4) Refrigerant Condensers. A potable water line to a single wall refrigerant condenser shall be provided with a backflow preventer complying with ASSE 1012 or 1013.

5) No pipe or fitting of the water supply system shall be drilled or tapped nor shall any band or saddle be used except at the water main in the street.

f) Devices for the Protection of the Potable Water Supply. Approved backflow preventers or vacuum breakers shall be installed with all plumbing fixtures and equipment that may have a submerged potable water supply outlet and that are not protected by a minimum fixed air gap. Connection to the potable water supply system for the following fixtures or equipment shall be protected against backflow with one of the appropriate devices as indicated below:

1) Inlet to receptacles containing low hazard substances (steam, compressed air, food, beverages, etc.):

- A) fixed air gap fitting;
- B) reduced pressure principle backflow preventer assembly;
- C) atmospheric vacuum breaker unit;
- D) double check valve backflow preventer assembly;
- E) double check backflow preventer with atmospheric vent assembly; or
- F) dual check valve.

2) Inlet to receptacles containing high hazard substances (vats, storage containers, plumbing fixtures, etc.):

- A) fixed air gap fitting;
- B) reduced pressure principle backflow preventer assembly; or
- C) atmospheric vacuum breaker unit.

3) Coils or jackets used as heat exchangers in compressors, degreasers, and other such equipment involving high hazard substances:

- A) fixed air gap fitting; or
- B) reduced pressure principle backflow preventer assembly.

4) Direct connections which are subject to back pressure:

A) Receptacles containing low hazard substances (vats, storage containers, plumbing fixtures, etc.):

- i) fixed air gap fitting;
- ii) reduced pressure principle backflow preventer assembly;
- iii) double check valve backflow preventer assembly;

- iv) double check backflow preventer with atmospheric vent assembly; or
- v) dual check valve.
- B) Receptacles containing high hazard substances (vats, storage containers, etc.):
 - i) fixed air gap fitting; or
 - ii) a reduced pressure principle backflow preventer assembly.
- 5) Inlet to or direct connection with sewage or lethal substances: fixed air gap fitting.
- 6) Hose and spray units or stations shall be protected by one of the appropriate devices as indicated below:
 - A) Fixed air gap;
 - B) Reduced pressure principle backflow preventer assembly;
 - C) Double check valve backflow preventer assembly;
 - D) Double check valve backflow preventer with atmospheric vent assembly;
 - E) Dual check valve backflow preventer assembly;
 - F) Atmospheric Vacuum Breaker Unit.
 - g) Installation of Devices or Assemblies.
 - 1) Devices of All Types. Backflow preventer assemblies and devices shall be installed to be accessible for observation, maintenance and replacement services. Backflow preventer devices or assemblies shall not be installed where they would be subject to freezing conditions.
 - 2) All in-line backflow/back siphonage preventer assemblies shall have a full port type valve with a resilient seated shut-off valve on each side of the preventer. Relocation of the valve is not permitted.
 - 3) A protective strainer shall be located upstream of the first check valve on all backflow/back siphonage preventers unless the device contains a built-in strainer. Fire safety systems are exempt from the strainer requirement.
 - 4) Atmospheric Vacuum Breakers. Vacuum breakers shall be installed with the critical level above the flood level rim of the fixture they serve, and on the discharge side of the last control valve of the fixture. No shut-off valve or faucet shall be installed beyond the vacuum breaker.
 - 5) Double Check Valve, and Reduced Pressure Principle Backflow Preventer Assemblies. No in-line double check valve backflow preventer assembly (DCV) or reduced pressure principle backflow preventer assembly (RPZ) shall be located more than 5 feet

above a floor, or be installed where it is subject to freezing or flooding conditions. After installation, each DCV and RPZ shall be field tested in-line in accordance with the manufacturer's instructions by a cross-connection control device inspector before initial operation.

6) A dual check backflow preventer with atmospheric vent assembly shall not be installed where it is subject to freezing or flooding conditions.

7) Closed water systems shall have a properly sized thermal expansion tank located in the cold water supply as near to the water heater as possible and with no shut-off valve or other device between the heater and the expansion tank. Exception: In existing buildings with a closed water system, a properly sized pressure relief valve may be substituted in place of a thermal expansion tank. For closed water systems created by backflow protection in manufactured housing, a ballcock with a relief valve may be substituted for the thermal expansion tank.

Special Applications and Installations

a) An atmospheric vacuum breaker shall be installed between the control valve and the fixture and in such a manner that it will not be subject to water pressure, except the pressure incidental to water flowing to the fixture. An atmospheric vacuum breaker shall be installed on the outlet side of the control valve.

b) Flushometer Valve. Flush valves shall be equipped with vacuum breakers installed on the discharge side of the flushing valve with the critical level at least 4 inches above the overflow rim of the bowl or 4 inches above the top of the urinal.

c) Flushing Tanks. Flushing tanks shall be equipped with anti-siphon ball cocks. The ball cock shall be installed with the critical level of the vacuum breaker at least one inch above the full opening of the overflow pipe. In cases where the ball cock has no hush tube, the bottom of the water supply inlet shall be installed one inch above the top of the overflow pipe.

d) Lawn Sprinklers. Any lawn sprinkler system connected to a potable water supply shall be equipped with a reduced pressure principle backflow preventer assembly (RPZ). The RPZ may be located outside provided it is protected from freezing or is removed at the end of the season.

e) Valve Outlets for Hose Attachments.

1) All threaded valve outlets shall have backflow protection. All outside threaded valve outlets shall not be subject to freezing.

2) Yard hydrants shall be installed as follows:

A) Potable Water. All hydrants with threaded spigots shall have backflow protection attached to the hydrant spigot (if threaded) and either:

i) Hydrants with buried drain down (weep) holes shall have the drain down (weep) holes protected from ground water backup by proper open site drainage. A backflow

preventer shall not be used on the buried drain down (weep) hole to protect the hydrant from ground water backup; or

ii) A yard hydrant that automatically drains back to a sealed container when flow is shut off, such as a canister type hydrant.

B) Non-potable Water

One or more hydrants may be installed for non-potable use if they are isolated from the potable water supply by a properly installed backflow preventer device. The hydrants must be clearly identified as non-potable by color and bear a sign that reads as follows: "This water unsafe for drinking."

3) In a campground licensed a backflow protection is not required if the water supply line is directly connected to a recreational vehicle and is under constant pressure.

f) Commercial Laundry Machines. The potable water supply to commercial laundry machines shall be protected against back siphonage by an air gap or backflow protection device. If a vacuum breaker is used, it shall be a minimum of 26 inches above the top of the machine.

g) Commercial Dishwashers. Commercial dishwashers shall be equipped with an approved vacuum breaker located in the rinse water supply line on the discharge side of the final control valve, a minimum distance of 6 inches above the uppermost spray outlets. The cold water or make-up water supply line shall be provided with an air gap or a vacuum breaker located on the discharge side of the final control valve, a minimum distance of 6 inches above the overflow level or flood rim.

h) Aspirators. Water operated aspirators shall meet the following specifications:

1) The water supply line shall be equipped with a shut-off valve.

A) In operating rooms, emergency rooms, recovery rooms, delivery rooms, autopsy rooms, dental offices and laboratories where aspirators are installed for removing blood, pus and/or other fluids, a vacuum breaker shall be installed on the discharge side of the control valve, at ceiling height (a minimum of 7 feet, 6 inches); or a reduced pressure principle backflow preventer assembly shall be used.

B) Water operated aspirators used for dispensing detergent shall be protected against backflow and back siphonage by an atmospheric vacuum breaker or a reduced pressure principle backflow preventer assembly.

2) The aspirator water discharge shall be provided with a 2 inch air gap to the receiving fixture.

UNION FITTING

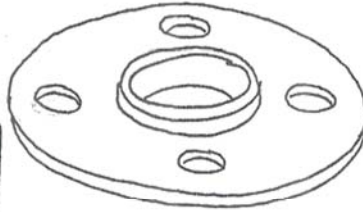
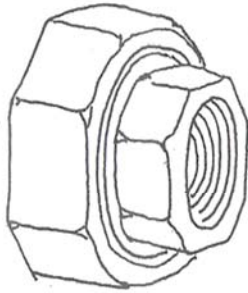

FLANGE

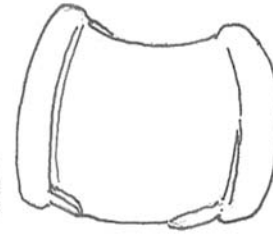

45 DEGREE ELBOW

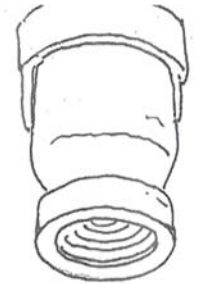

REDUCER

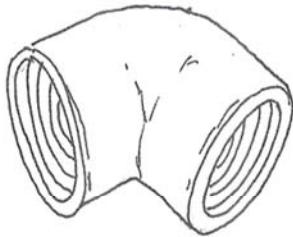

90 DEGREE ELBOW

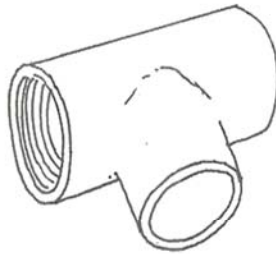

TEE



BUSHING



COUPLING



45 DEGREE STREET ELBOW



REDUCER

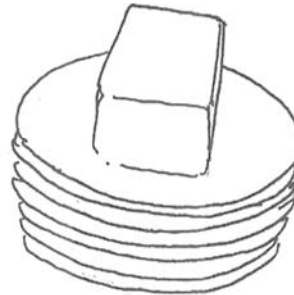

PLUG

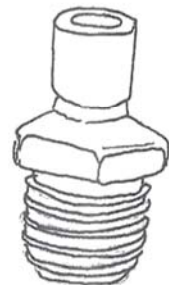

EXTENSION PIECE

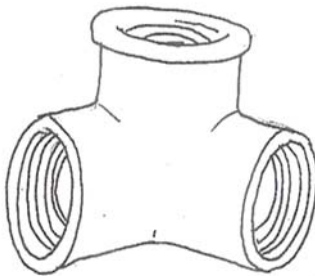

SIDE OUTLET ELBOW

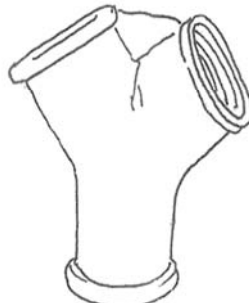

Y ELBOW

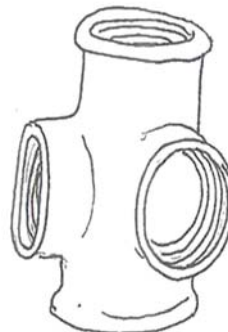

TEE WITH SIDE OUTLET

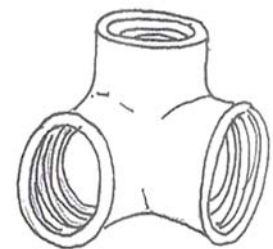

OUTLET ELBOW

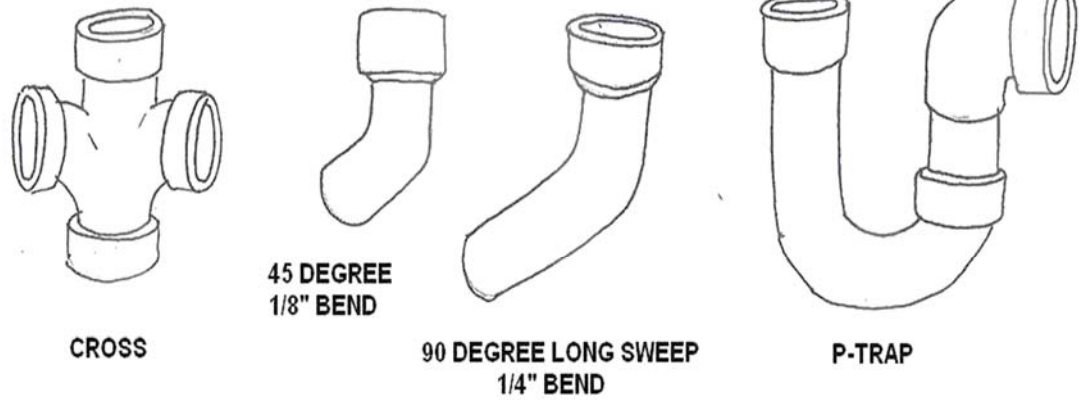
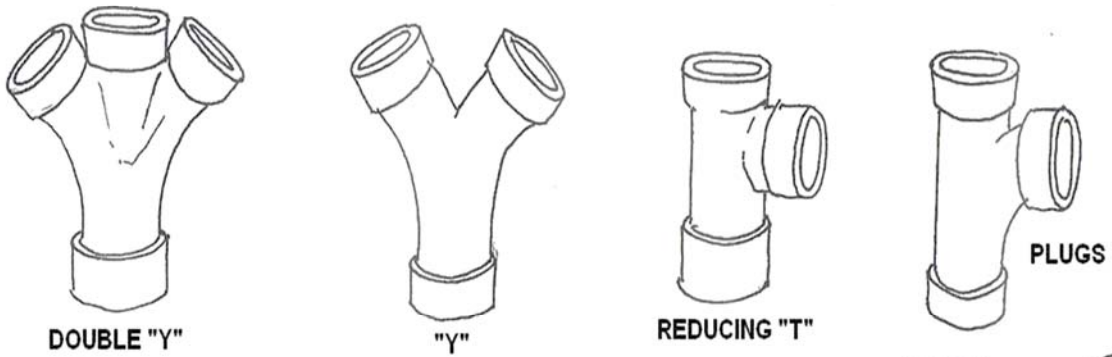
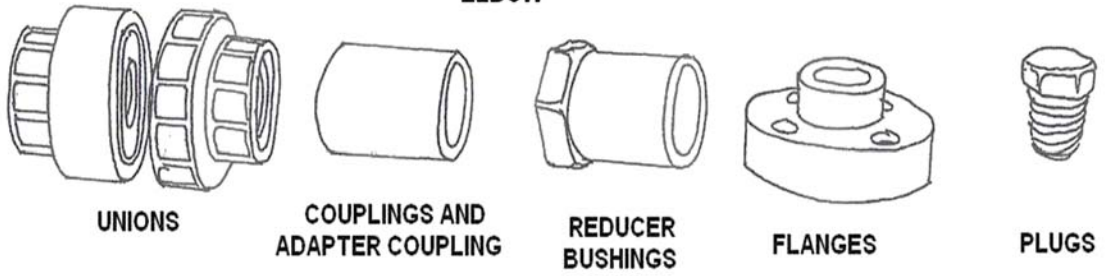
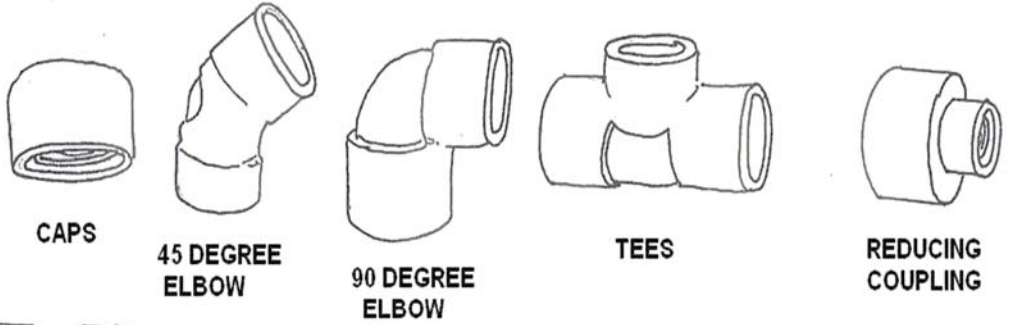

WASTE DRAINAGE FITTINGS



2-Way Cleanout DWV Soil Pipe, needs to be within 2 feet of the house, perpendicular (not parallel) to the footing and the end or grade level needs to be painted to protect from sunlight.



Sewer lateral going into a manhole.

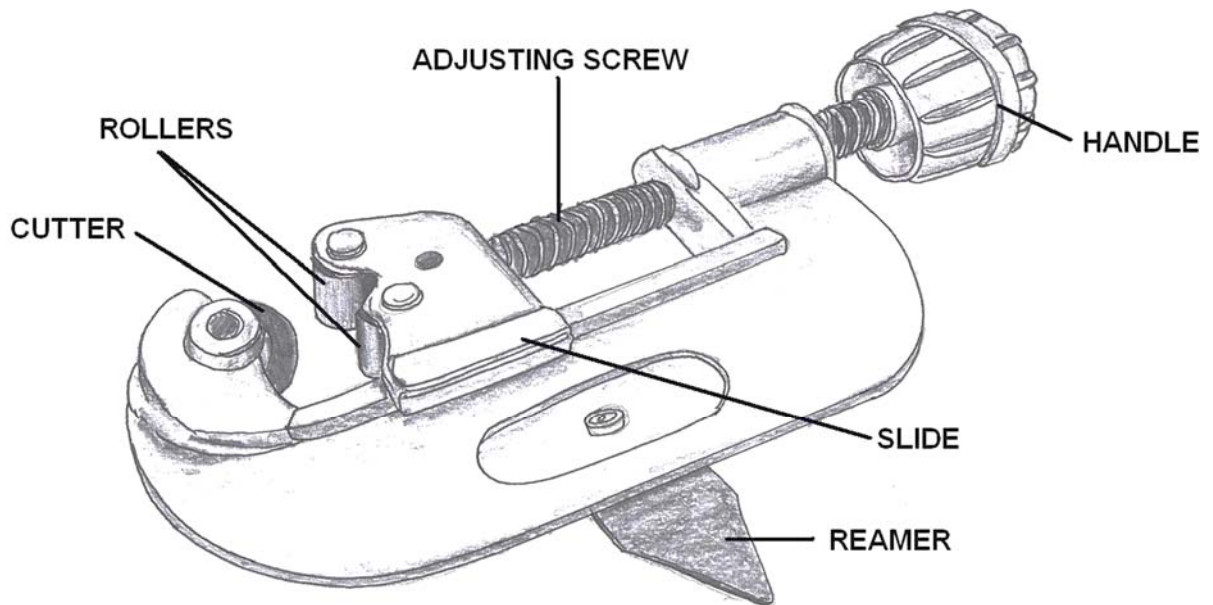
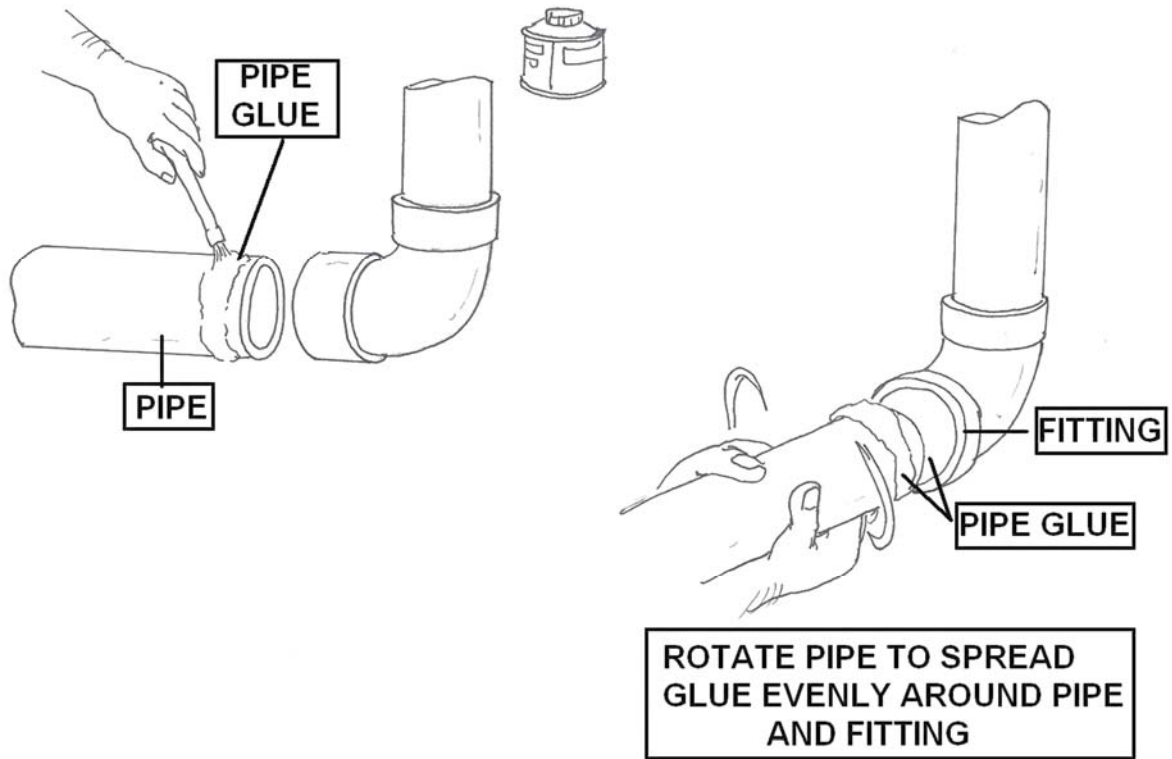

TUBING CUTTER

Plumbing Fittings Chapter 3

Copper is a popular material for water supply line. It's durable pipe that handles high water pressure loads and is relatively easy to work with.

However, copper is expensive and may cost up to three times more than plastic CPVC (chlorinated polyvinyl chloride) pipe.



Soldering pipe, there are several types of copper pipe. Soft and rigid, K-Green, L-Blue, M-Red, and DWV-yellow. You can no longer use lead solder for potable water. Copper lines fit together with lead-free, solid-core solder.

The soldering process involves heating the pipe and is commonly called "sweating."



Lavatory or bathroom set-up with a Dirty Arm and possible water softener loop.

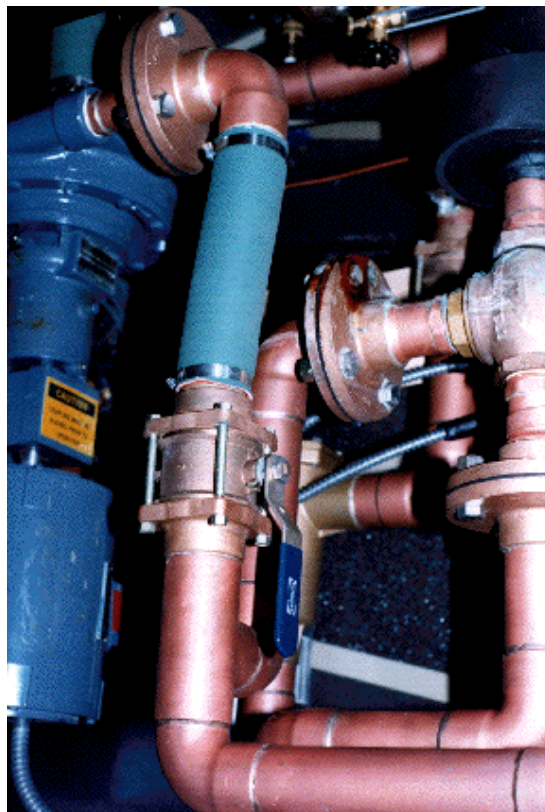

Various copper fittings. I predict that we will no longer see copper fittings utilized in plumbing by the year 2020. The price of copper is going sky high.

Plastic Pipe and Fittings

Proper solvent cementing techniques are fundamental to successful installation. The following techniques provide the basis for strong and durable solvent cement joints.

Considering that the majority of piping installation failures are the result of improper cementing techniques, an understanding of the proper techniques required for joining saves both time and money. A quality solvent cement joint furnishes strength to the entire system. Likewise, no system is fully effective when even a single joint is poorly cemented. Obviously, a fair amount of time devoted to preparation will pay off upon completion.

The first step in solvent cementing consists of inspecting the pipe and fittings for overall appearance and compatibility. Obvious defects such as cracks, burrs and incompatible materials must be addressed as required. The joining surfaces must be clean and dry. In addition, the proper cement for the type and size of pipe and fittings should be determined.

Also, remember both temperature and humidity may be issues to consider. Another detail that is often overlooked is the need to have the correct size applicator for the size of pipe. The general rule is to have an applicator about half the size of the pipe diameter in order to assure proper and timely solvent cement coverage.

Next, proper technique requires that the pipe be cut square with a fine-toothed saw or tube cutters. The use of ratcheting cutters, which grip and shear pipe like strong scissors, can generate cracks in the ends of pipe. A square cut promotes proper beveling and full contact between the pipe and the pipe stop in a fitting.

Following the cutting of the pipe, beveling should be accomplished by using a file or a chamfering tool. A slight beveling of 1/16th inch removes burrs and debris and promotes the formation of a bead of cement at the base of the socket. While beveling the pipe, one should also clear any debris from the waterway of the pipe and clean the area to be primed. A "dry fit" of the pipe and fittings is recommended in order to check for proper fit, depth and alignment.

Moving on to the actual assembly of the components, the first order of business is to apply the appropriate primer. Primer is used to clean, dissolve and penetrate the surfaces of the pipe and fittings. It is important to consider the use of a properly sized applicator, preferably a brush at least one-half the size of the pipe being primed.

The primer should be liberally applied to the fitting socket and to that portion of the pipe, which will fit into the socket. Repeated applications of primer may be required.

Immediately after the application of the primer, the solvent cement should be freely applied to both the fitting and the pipe. Again, not only may repeated applications be required but an appropriately sized applicator should be used. With the surfaces still wet, the pipe should be inserted into the fitting socket with a quarter turn twisting motion, bottoming out the pipe.

The importance of assembling fittings and pipe while the solvent cement is still wet cannot be underestimated. If the job requires it, two people should be involved in the priming and cementing process. Finally, the cemented joint should be held together for at least thirty seconds to prevent the parts from separating and the parts should be allowed to set an appropriate period of time before further work or pressurization is attempted.

If the preceding steps are followed, the confidence in the level of durability and strength of the solvent-cemented joints should be very high.



Picture provided by Spears Manufacturing Company

Tee Slip



Picture provided by Spears Manufacturing Company

Reducer Tee



Picture provided by Spears Manufacturing Company

90° Reducer Elbow



Picture provided by Spears Manufacturing Company

Ball Valve Slip Fitting



Picture provided by Spears Manufacturing Company

Flange Butterfly Valve

Solvent Cementing Section

This section was developed to aid the installer in the proper techniques needed for the joining of plastic pipe and fittings.



Solvent Cementing is the most popular kind of CPVC joining method.

Remember, always wear eye protection and gloves.

Here are the solvent cementing procedures:

1. Cut the pipe with cutter or saw. Cut the pipe in square to provide optimal bonding area. See the above picture on the right.
2. De-bur the pipe with chamfering tool or file to ensure proper contact between pipe and fitting. Remove all burrs from both the inside and outside of the pipe with a knife, file or reamer. Burrs can scrape channels into pre-softened surfaces or create hang-ups inside surface walls. Remove dirt, grease and moisture. A thorough wipe with a clean dry rag is usually sufficient. (Moisture will retard cure and dirt or grease can prevent adhesion).



3. Apply a heavy, even coat of CPVC primer (if necessary) to the fitting. Remember, Ladies first. Use the right applicator for the size of pipe or fittings being joined.

The applicator size should be equal to 1/2 the pipe diameter. It is important that a satisfactory size applicator be used to help ensure that sufficient layers of cement are applied.

4. Apply a heavy, even coat of primer (if necessary) to the pipe end. The purpose of a primer is to penetrate and soften the surfaces so they can fuse together. The proper use of a primer and checking its softening effect provides assurance that the surfaces are prepared for fusion in a wide variety of conditions. Check the penetration or softening on a piece of scrap before you start the installation or if the weather changes during the day. Using a knife or other sharp object, drag the edge over the coated surface. Proper penetration has been made if you can scratch or scrape a few thousandths of the primed surfaces away. Because weather conditions do affect priming and cementing action, repeated applications to either or both surfaces may be necessary. In cold weather, more time is required for proper penetration.



5. Apply a heavy, even coat of CPVC cement (if necessary) to the fitting. Remember, Ladies first; then apply to the pipe end. Stir the cement or shake can before using. Using the proper size applicator for the pipe size, aggressively work a full even layer of cement onto the pipe end equal to the depth of the fitting socket -do not brush it out to a thin paint type layer, as this will dry within a few seconds.

6. Insert the pipe into the fitting socket, rotating ¼ to ½ turn. Hold the pipe for 10 seconds, allowing the joint to set-up. A nice thing about plastic pipe is that if you make a mistake, you can cut the section out and re-do it.

7. The joining is finished. Cure time depends on pipe size, temperature and relative humidity. If local codes permit, successful joints can be made without a primer using cement alone, but extra care must be given to the installation. It is important that a good interference fit exists between the pipe and fittings. It is for this reason we recommend that joints being made without a primer be limited to systems 2" and smaller for pressure applications (water systems only) or 6" and smaller for DWV or non-pressure applications. Extra care must also be given in applying the cements to make sure proper penetration and softening of the pipe and fitting surfaces is achieved.

8. Joint strength develops as the cement dries. In the tight part of the joint the surfaces will tend to fuse together; in the loose part, the cement will bond to both surfaces. These areas must be softened and penetrated. Penetration and softening can be achieved by the cement itself, by using a suitable primer or by the use of both primer and cement. For certain materials and in certain situations, it is necessary to use a primer. A suitable primer will usually penetrate and soften the surfaces more quickly than cement alone.

Plumbing Fittings

Fittings (faucets and valves) are used more often than any other part of the plumbing system. They get plenty of use but are built to take it, under normal conditions.

The best modern fittings are all chrome plated brass and will last a lifetime under everyday use. They clean easily with soap and warm water.

Caution: The metal chromium is easily dissolved in hydrochloric acid and sulfuric acid. Muriatic acid has for years been considered a good tile cleaner, but only where there are nickel plated plumbing fittings. Where chrome plating is present, clean bathroom tile with warm oxalic acid, never with Muriatic or sulfuric acids. Even covering the chromium surfaces with cloths will not prevent the acid fumes from inflicting permanent damage.

Gaining in popularity are polished brass fittings and trim. These will hold up well, as long as certain precautions are observed. NEVER use any abrasive cleaner on polished brass. This can scratch the protective coating on the brass finish resulting in a deterioration or pitting of the brass plating. Also avoid use of solvent based cleaners because they can be deleterious to the polished brass finish.

New technologies have brought about the development of improved finishes that can withstand more wear, but check the manufacturer's warranty to determine whether or not you have the "new and improved" lifetime warranty finish.



Picture provided by Spears Manufacturing Company

Diaphragm Valve with flow indicator.



Picture provided by Spears Manufacturing Company

Gate Valve



Picture provided by Spears Manufacturing Company

Swing Check Valve



Picture provided by Spears Manufacturing Company

Three-Way Valve Slip



Picture provided by Spears Manufacturing Company

Thread FIP Cap



Picture provided by Spears Manufacturing Company

Reducer



Picture provided by Spears Manufacturing Company

CTS Drop FIP to Slip 90°

Chapter Summary

By understanding the nature of waterborne diseases, the importance of properly constructed, operated and maintained public water systems becomes obvious. While water treatment cannot achieve sterile water (no microorganisms), the goal of treatment must clearly be to produce drinking water that is as pathogen-free as possible at all times.

"Sweating" pipes and plumbing fixtures in summer-time or during seasonal changes are not a sign of faulty plumbing. Due to condensation of water vapor in the air, beads of moisture will form in warm weather on any pipes and fixtures containing cold water.

Normally, when not in use, the water and fixtures will warm rapidly to room temperature and the condensation will stop. When a closet tank or other fixture continues to sweat for hours after it has been used, it is a sign that cold water is continuing to flow through it, possibly due to an improper adjustment of the tank valve or a leak.

Sweating pipes can be wrapped with an insulation material which prevents the condensation and formation of moisture.

There are several types of copper pipe. Soft and rigid, K-Green, L-Blue, M-Red, and DWV-yellow.

You cannot use lead solder for potable water.

Cut plastic pipe to length with a hacksaw, or abrasive disk of a miter saw/chop saw. After each cut, clean out the small burrs/shavings that remain inside the pipe with a knife, rag or emery cloth.



Check small pipes and fittings for plumb/level with a torpedo level. Also, double check the drain flow; about 1/4" per 1' as a general guide.

A fitting that's glued crooked can sometimes throw off the whole run and/or won't fit properly with the next piece. Discover these problems during the dry fit rather than after the pipe is glued.

To glue ABS pipe, check that any cut ends are fairly straight. Remove any burrs with a knife or emery cloth and clean both pieces with a rag. Apply ABS glue to both the pipe and fitting.

Push the joints together with a twisting motion to spread the glue. Hold the joints together for a few seconds so they won't push apart while the fast-drying glue sets.

Gluing PVC pipe is a similar process, but a cleaning chemical (primer) that prepares the plastic goes on before the glue. CPVC pipe also has its own type of glue so be sure to purchase the glue that matches the plastic you're working with. Once the joint is primed, apply the glue to the joints, push and twist the pipe or fitting and hold them in place for a few minutes.

Types of Joints - Assignment Question 78

- a) **Caulked joints.** Caulked joints for (drain, waste and vent systems only) cast iron hub-and-spigot pipe shall be firmly packed with oakum or hemp and filled with molten lead at least one inch deep and be firmly caulked not to extend more than 1" below the rim of the hub. Paint, varnish, or other coatings shall not be permitted on the jointing material until after a plumbing inspector has been given the opportunity to test and approve or disapprove the joint.
- b) **Threaded/Screwed Joints.** Threaded joints shall conform to American National Taper Pipe Thread, ASME B.1.20.1-1983 (General Purpose). All burrs shall be removed; pipe ends shall be reamed or filed to size of the bore and all chips shall be removed. Pipe joints compound shall be insoluble in water and non-toxic.
- c) **Wiped Joints.** Joints in lead pipe or fittings, or between lead pipe fittings and brass or copper pipe ferrules, solder nipples, or traps shall be full-wiped joints. Wiped joints shall have exposed surface on each side of the joint at least $\frac{3}{4}$ " and at least as thick as the material being joined. Wall or floor flange lead-wiped joints shall be made by using a lead ring or flange placed behind the joints at the wall or floor. Joints between lead pipe and cast iron, steel or wrought iron shall be made by means of a caulking ferrule, soldering nipple, or bushing. Note: Lead joints and lead fixtures have been banned.
- d) **Soldered Joints.** The surface to be soldered shall be cleaned bright. The joints shall be properly fluxed (lead free) and made with approved lead free solder conforming to ASTM Standard B32-1989. Joints in copper water tubing shall be made with approved cast bronze or wrought copper pressure fittings, properly soldered together. All solders or flux containing more than 0.2% lead shall bear a warning label which states that the solder or flux is not approved for private or potable water use as required by Section 4 of the federal Hazardous Substances Act (15 USC 1263). Use of this product in the making of joints or fittings in any private or public potable water system is prohibited. No part of a DWV (drain, waste and vent) system shall be joined or fitted with a solder or flux containing more than 0.2% lead. Note: Lead joints and lead fixtures have been banned.
- e) **Flared Joints.** Flared joints for plastic pipe and tubing and soft copper water tubing shall be made with approved fittings. The tubing shall be expanded with a proper flaring tool.
- f) **Hot-Poured Joints.** Hot-poured compound for clay or concrete sewer pipe shall not be water absorbent and when poured against a dry surface shall have a bond of at least 100 pounds per square inch (p.s.i.). All surfaces of the joint shall be cleaned and dried before pouring. If wet surfaces are unavoidable, a suitable primer such as oil or tar shall be applied. The compound shall not soften sufficiently to destroy effectiveness of the joint when subjected to a temperature of 160°F, and not be soluble in any of the waste carried by the drainage system. Approximately 25 percent of the joint space at the base of the socket shall be filled with jute or hemp. A pouring collar rope or other device shall be used to hold the hot compound during pouring. Each joint shall be poured in one operation until the joint is filled. Joints shall not be tested until one hour after pouring. Note: Lead joints and lead fixtures have been banned.

- g) **Precast Joints.** Precast collars shall be formed in both the spigot and bell of the pipe in advance of use. Prior to making joint contact, surfaces shall be cleaned. When the spigot end is inserted in the collar, it shall bind before contacting the base of the socket.
- h) **Brazed Joints.** Brazed joints shall be made by first cleaning the surface to be joined down to the base metal, applying flux approved for such joints and for the filler metal to be used, and making the joints by heating to a temperature sufficient to melt the approved brazing filler metal on contact. An extracted mechanical joint may be made in copper tube types K or L only for water distribution. The joint shall be made with a mechanical extraction tool and joined by brazing. To prevent the branch tube from being inserted beyond the depth of the extracted joint, depth stops shall be provided. This joint shall be for above ground use only.
- i) **Cement Mortar Joints.** Except for repairs, cement mortar joints are prohibited.
- j) **Burned Lead (Welded).** (For drain, waste and vent system only) Every burned (welded) joint shall be made in such manner that the 2 or more sections to be joined shall be uniformly fused together into one continuous piece. The thickness of the weld shall be at least as thick as the lead being joined. Note: Lead joints and lead fixtures have been banned.
- k) **Bituminized Fiber Pipe Joints.** Joints in bituminized fiber pipe shall be made with tapered type couplings of the same composition as the pipe. Joints between bituminized fiber pipe and metal pipe shall be made by means of an adaptor coupling caulked as required in subsection (a) of this Section.

Plastic Pipe Joints - Assignment Question 97

- 1) Every joint in plastic piping shall be made with approved fittings by either solvent welded or fusion welded connections, compression fittings, approved insert fittings, metal clamps and screws of corrosion resistant material, or threaded joints.
- 2) **Joints and Fittings in Plastic Pipe.** Potable water piping fittings and joints shall be in accordance with the manufacturer's recommendations.
- A) Polyethylene (PE) pipe shall be installed only with compression fittings, insert and clamp type fittings or thermal welded joints and fittings. All clamps shall be of corrosion resistant material. The inside diameter (I.D.) of any insert fitting shall not be less than the minimum allowable size for water service/distribution piping.
- B) Polyvinyl chloride (PVC) pipe shall be installed with solvent welded or flanged joints only. The pipe shall not be threaded. Transition to metallic or other piping shall be made with the use of adaptor fittings. The fittings shall be molded from polyvinyl chloride. The primer and solvent cement used shall be in accordance with the manufacturer's recommendation for polyvinyl chloride piping.

C) Polybutylene (PB) pipe shall be installed only with insert and clamp type fittings, compression type, flanged type, or thermal welded joints and fittings. All clamps shall be of corrosion resistant material. The inside diameter (I.D.) of any insert fitting shall not be less than the minimum allowable size for water service/distribution piping.

3) Joints in Plastic Drainage. Joints in plastic drainage piping or vent piping within a building shall be solvent welded. Threaded or flanged joints may be used with adaptor fittings. The solvent cement shall be specific for the type of piping material. O-ring expansion joints are acceptable if accessible.

m) Ground Joint Connections. Ground joint connections (when accessible) may be used on the inlet or outlet side of a fixture trap or within the trap seal. Ground joint connections shall not be used in any inaccessible drainage piping.

n) No-Hub Soil Pipe Joints. Shielded joints for no-hub cast iron soil pipe shall be made with an elastomeric gasket covered by either a stainless steel shield secured by 2 or more stainless steel bands or clamps, or covered by cast iron couplings secured with stainless steel nuts and bolts. When a stainless steel shield is used, the shield and clamps shall be corrosion resistant and homogeneous throughout.

o) Compression Type Joints.

1) Compression type joints for hub and spigot cast iron soil pipe shall be made with neoprene insert gaskets in accordance with ASTM C564. The pipe shall comply with the specifications contained in ASTM A-74 with regard to hub and spigot dimensions and tolerances.

2) Compression type joints for copper water tube or brass tube shall be made with brass ferrules and ground joint connections.

p) Grooved Type Mechanical Couplings.

1) Cut grooved type mechanical couplings, fittings and valves used on standard weight galvanized steel pipe, cast iron pipe or ductile iron pipe shall comply with the grooving dimensions of the AWWA specifications C606-78, limited to water distribution piping and downspout pipe above ground.

2) Rolled grooved type mechanical couplings, fittings and valves used on standard weight galvanized steel pipe or type K or L copper tubing shall comply with the manufacturer's standard, limited to water distribution piping above ground. Fittings, couplings and valves shall be compatible with the pipe material. Transition adapters shall be dielectric type.

3) Gaskets for use with potable water piping shall be fabricated from material that is non-toxic, durable and impervious.

q) Copper Press Fittings. Copper press fittings for joining copper water tubing shall have an elastomeric o-ring that forms the joint. The fitting shall be made by pressing the socket joint under pressure in accordance with the manufacturer's installation requirements and NSF Standard 61.

Tightness Joints and Connections

Joints and connections shall be gas-tight and water-tight.

Special Joints

- a) Copper Tubing to Screwed Pipe Joints. Joints from copper tubing to threaded pipe shall be made by the use of a cast bronze or wrought copper adaptor fitting. The joint between copper tubing and the fitting shall be soldered or, if flared or compression, must be accessible.
- b) Welding or Brazing. Brazing or welding shall be in accordance with the provisions of Section 6 of the Code for Pressure Piping, ANSI B.3.1 and ANSI B.3.L.1.
- c) Slip Joints. In drainage and water piping, slip joints may be used on the inlet side of the trap or in the trap seal, and on the exposed fixture supply. Slip joints shall not be used in any inaccessible piping. Push-on angle stop valves are permitted, provided they meet the following specifications: they are installed by being pushed onto copper or CPVC; they are mechanically secured by metal tabs which grip the piping; they are sealed with o-rings; and they are capable of withstanding a water pressure of 150 pounds per square inch and a temperature of 210 degrees Fahrenheit.
- d) Expansion Joints. Expansion joints must be accessible and may be used where necessary to provide for expansion or contraction of the piping. The expansion joint material shall conform to the type piping on which it is installed.
- e) Compression type couplings shall not be used in unexposed water piping except for water services, water meter yokes and stop box connections.
- f) Grooved Type Mechanical Couplings. Grooved type mechanical couplings, in accordance with Section 890.320(p), may be used in potable water and roof drain piping. Such couplings shall not be used in waste, soil or vent piping.
- g) Plastic Pipe to Non-Plastic Pipe Joints. Joints between plastic pipe and non-plastic pipe shall be made only by one of the following methods:
 - 1) Pressure piping.
 - A) Approved insert fittings.
 - B) Threaded adaptors.
 - C) Flanges.
 - D) Flared fittings.
 - 2) Non-pressure piping - Drain Waste Vent (DWV)
 - A) Caulked lead joints with caulked adaptors.

- B) No-hub soil pipe shielded couplings with approved adaptor having a raised bead.
- C) Compression type joints for hub and spigot cast iron pipe.
- D) Threaded adaptors.

Use of Joints – Question 117

- a) Clay Sewer Pipe. Joints in vitrified clay pipe or between such pipe and metal pipe shall be made with a neoprene gasket and stainless steel bands.
- b) Concrete Sewer Pipe. Joints in concrete sewer pipe or between such pipe and metal pipe shall be made with a neoprene gasket and stainless steel bands.
- c) Cast Iron Pipe. A joint in cast iron water supply pipe shall be made in accordance with Section 890.320(a) and (b) or shall be a mechanical joint.
- d) Screw Pipe to Cast Iron. Joints between wrought iron, steel, brass, or copper pipe, and cast iron pipe shall be either caulked or threaded joints which are made as provided in Section 890.320 (a) or (b) and shall be made with proper adaptor fittings.
- e) Lead to Cast Iron, Wrought Iron or Steel. Joints between lead and cast iron, wrought iron, or steel pipe shall be made by means of wiped joints to a caulking ferrule, soldering nipple, or brushing.
- f) Copper Water Tube. Joints in copper tubing shall be made with cast bronze or wrought copper pressure fittings, properly soldered or brazed, or by means of compression or flared joints. Flared joints and compression fittings shall not be installed underground except for water services, water meter yokes and stop box connections.
- g) Plastic Pipe. Joints between plastic pipe and non-plastic material shall be made only with an appropriate type adaptor.
 - 1) Plastic-Commingling. There shall be no commingling of plastic materials within the same plumbing system except through the use of proper adaptors.
 - 2) Plastic Pipe. Plastic pipe shall not be installed in any tunnel or chase that contains uninsulated hot water, hot air or steam piping which causes the ambient air temperature in the tunnel or chase to exceed 180°F.
- h) Building Sewer Connections. An elastomeric coupling seal conforming to ASTM C 425 (1988), ASTM C 443 (1985), ASTM C 564 (1988), ASTM D 4161 (1986), ASTM F 477 (1985), or ASTM D 3139 (1989), ASTM D 3212 (1989), or ASTM D 412 (1980) tests may be used to adapt any 2 building sewer pipes for different materials or size changes. The flexible couplings shall be attached to the pipe with stainless steel clamps or bolts. The manufacturer's recommended method of installation shall be followed.

Unions

Unions may be used in the drainage and venting system when accessibly located above ground. Unions shall be installed in a water supply system within 5 feet of regulating equipment, water heaters, water conditioning tanks, water conditioning equipment, pumps, and similar equipment which may require service by removal or replacement. Where small equipment may be unscrewed, only one union shall be required.

a) Drainage System. Unions may be used in the trap seal and on the inlet and outlet side of the trap. Unions shall have metal to metal seats except that plastic unions may have plastic to plastic seats.

b) Water Supply System. Unions in the water supply system shall be metal to metal with ground seats, except that plastic to metal unions may utilize durable, non-toxic, impervious gaskets. Unions between copper pipe/tubing and dissimilar metals shall either be made with a brass converter fitting or be a dielectric type union.

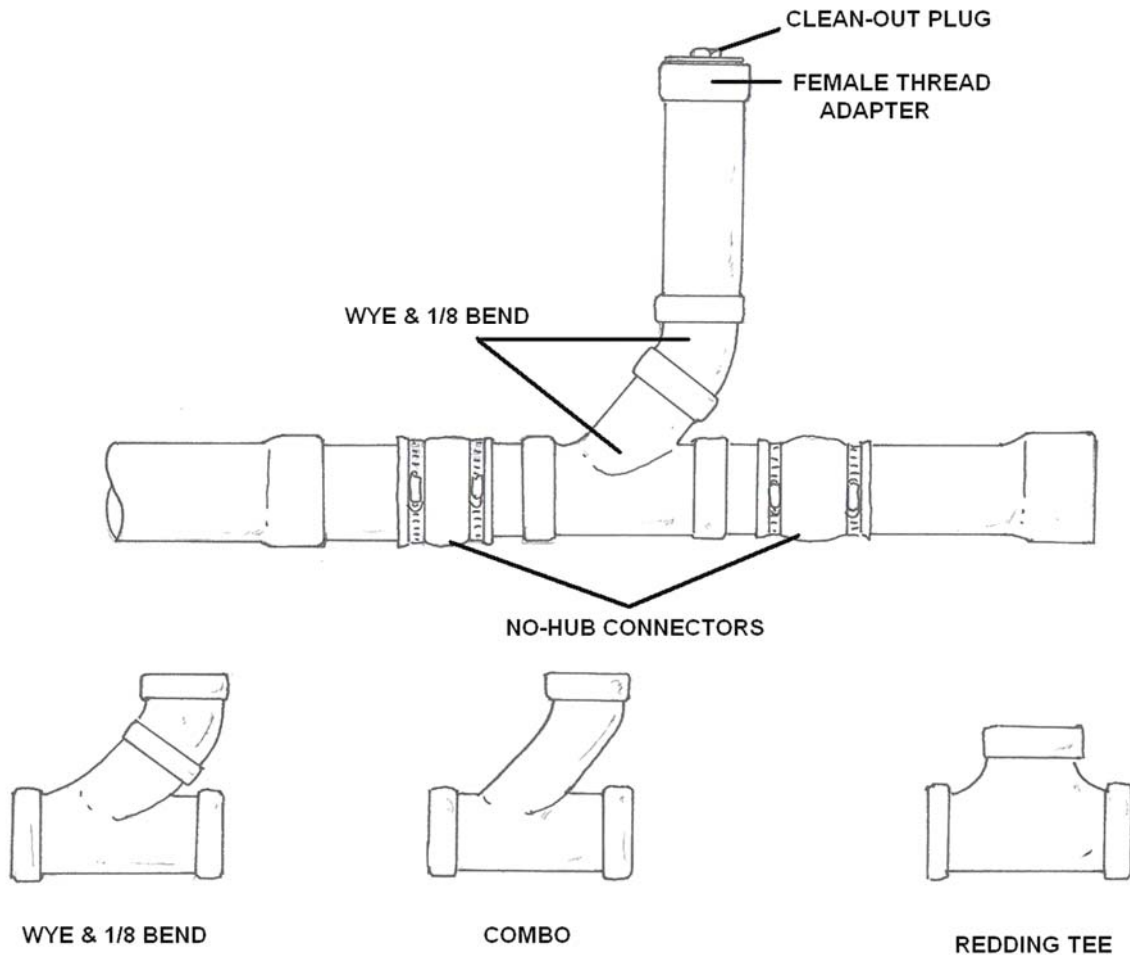

Plumbing Repairs Chapter 4

Faucets

Today, most faucets can be categorized as being washerless (port-type faucets), or of the Compression (washer) type.

Repairing Faucets

There are a few different types and combinations of faucets: single-handle or two-handled shut-offs that are compression or washerless (cartridge, ball or disc mechanism).

A compression faucet stops water by tightening down a rubber washer to block water flow.



A washerless faucet uses a rotating mechanism -- like a ball or valve -- to open and shut water flow.

A compression faucet usually has threaded brass stems that open/close firmly. A cartridge faucet has brass or plastic valves with holes in them and operate more easily.

Tips Before You Start

- Close the sink drain to avoid losing any parts.
- After locating the leak, shut off both water supplies before removing any parts.
- Tape wrench jaws to avoid marring the faucet's finish.
- Write down and/or lay out parts to remember their order.
- Buy a repair kit that includes a special adjusting ring wrench, seals, springs and O-rings rather than one or two pieces. Washer assortment kits may also be better than more expensive single washer packaging.
- If the faucet still leaks after installing a kit, the outer housing is probably cracked and buying a new faucet is probably the only way to fix the leak.

Washerless Faucets

Washerless faucets can be either single handle or the two handle type. In washerless faucets, the control of the water flow is done by a replaceable cartridge or arrangement of seals that allow water flow when the holes or ports are lined up in the proper configuration.

Giving the handle an extra hard twist to stop water flow will be ineffective. This type of faucet does not use compression strength to stop water flow.



Various Seats and Stems. Here is a money maker.

A washer-less faucet does not mean it will never leak, but rather because of the way it is designed, the parts will last much longer, as their design minimizes friction and wear.

When repairing this type of faucet or requesting service on one, it is vital that you know the brand name, or have a sample of the part you require, as there are hundreds of faucet cartridges and parts kits on the market today.

Compression Faucets

Like sink and lavatory faucets, wall mounted faucets fall into two categories: compression and non-compression types. Two-handle compression types feature O-rings and washers that you can replace. The non-compression version usually has a single handle pull-on, push off configuration, with a cartridge assembly beneath, when it leaks, the whole cartridge assembly usually requires replacement.

In a compression type faucet, you will find the conventional setup - a faucet washer on the end of the stem. Replacing the washer usually will correct a dripping faucet.

However, when removing the stem, always check the seat inside the faucet body - the brass ring that the washer grinds against. The faucet seat can be worn or grooved, making the washer replacement ineffective within days. The washer and seat are the two parts of a compression type faucet that receive the greatest amount of wear. It is not difficult to replace a washer. First, shut off the water supply.

Usually, the shut-off valve is under the sink in the kitchen, or in the bathroom, under the lavatory basin. If there is none, shut off the branch-line valve in the basement or the main valve where the water supply enters the house.

Pad a smooth jawed wrench with a cloth, then, using the padded wrench, unscrew the large packing nut and turn out the faucet stem. Then, with a screw driver that fits the screw slot closely, remove the screw from the bottom of the stem and pry out the worn washer. If the screw is tight or stubborn, tap its head lightly or apply penetrating oil (WD-40).

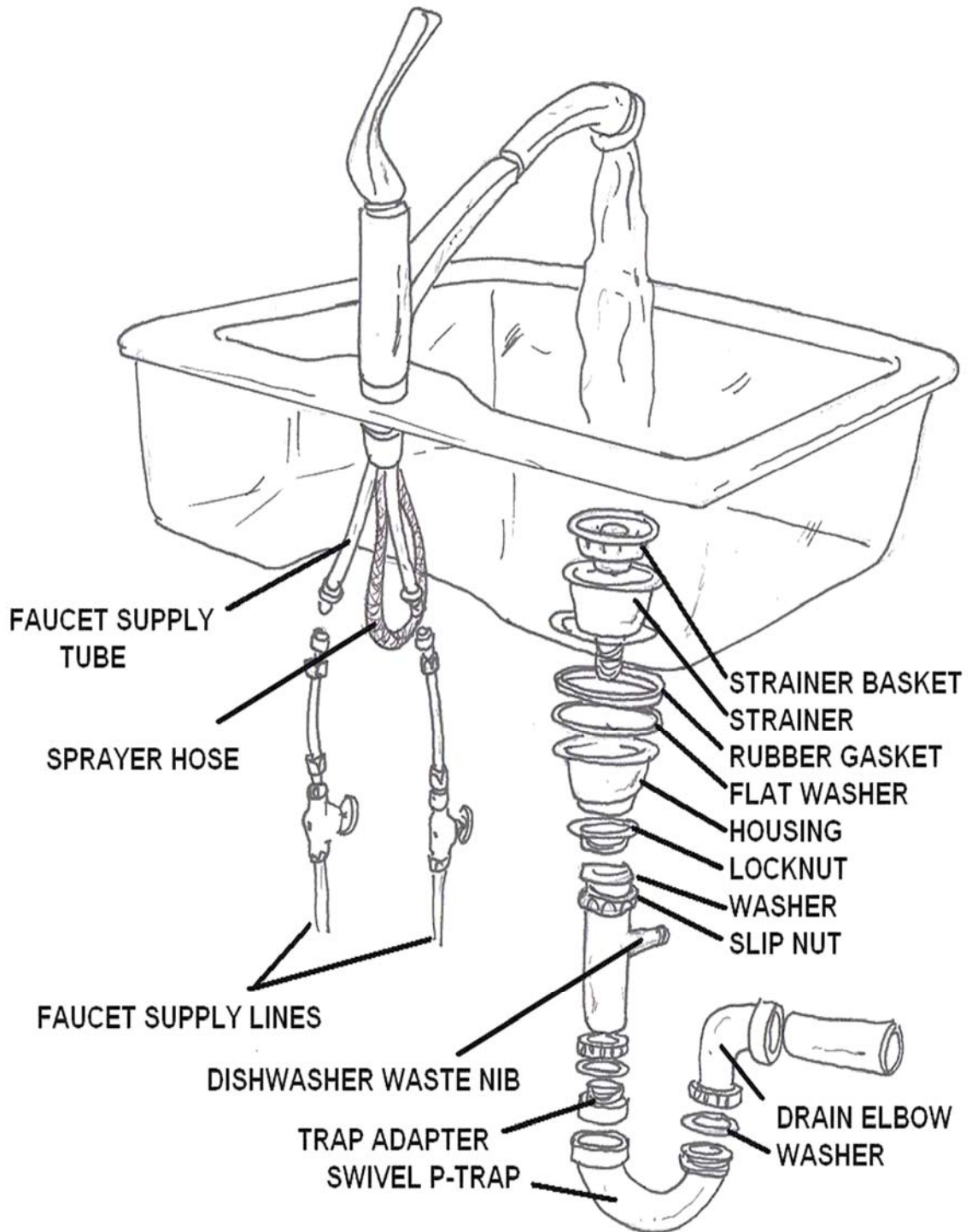

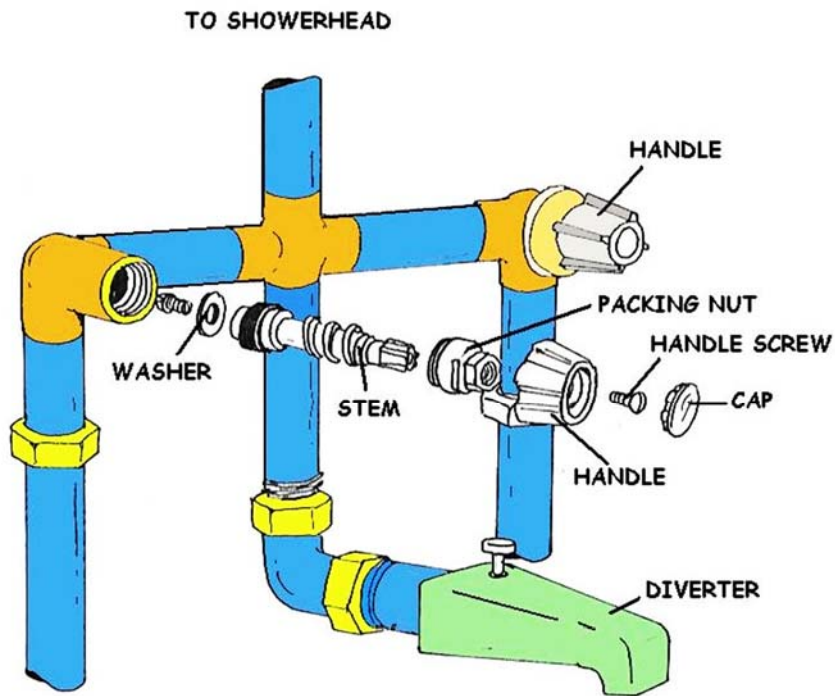

COMPRESSION FAUCET

Next, clean out the washer seat or compartment. When this is done, insert the new washer of the correct size and composition for hot or cold water.

Some of the newer, soft neoprene washers are for both hot and cold water and have a long life. The washer should fit snugly without having to be forced into position. After inserting, replace the screw and tighten.



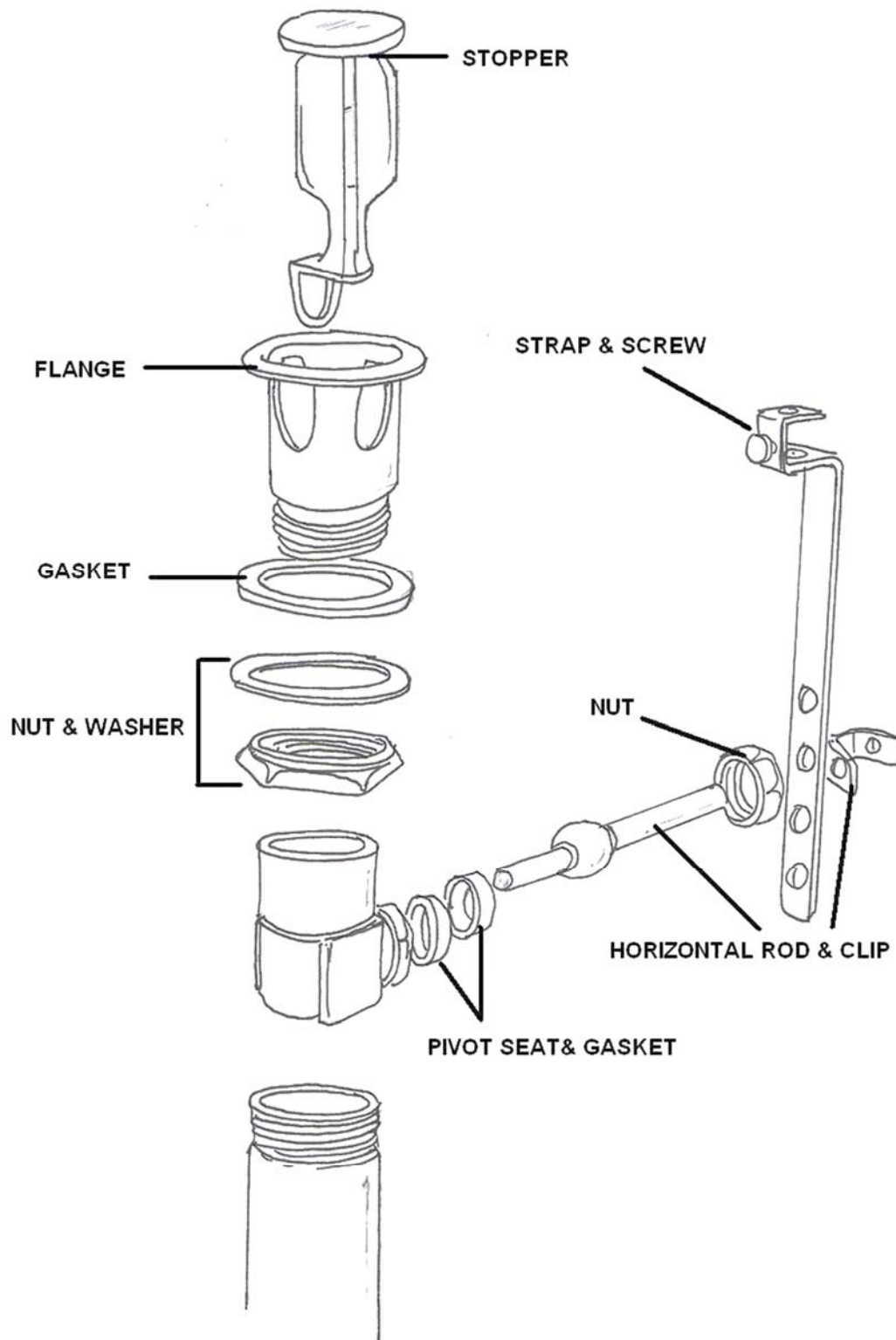

BASIC DRAIN STOP PARTS

Plumbing 101 9/1/2016©TLC (866) 557-1746 Fax (928) 272-0747

Worn Faucet

It is usually just as expensive to renew a seat as it is to buy a new faucet, unless it has been made with a renewable seat. Check with your plumbing supply store about a badly worn faucet.

With cloth over finger, clean the valve seat inside the faucet. The edge should be smooth and free from deep nicks. If you find it badly worn, you will probably need to replace the seat or have the entire faucet replaced by the plumber. Otherwise, it will leak again.

Next, replace the faucet stem and turn it in. Tighten the packing nut. Be careful not to tighten the nut more than necessary to stop seepage around the faucet stem.

A faucet leaking 60 drops a minute (not unusual) will waste 2,299 gallons of water every year. Homeowners should repair leaky faucets at once. You pay twice - once for the water going through the meter, and then again on your sewer bill, which is based on water usage.

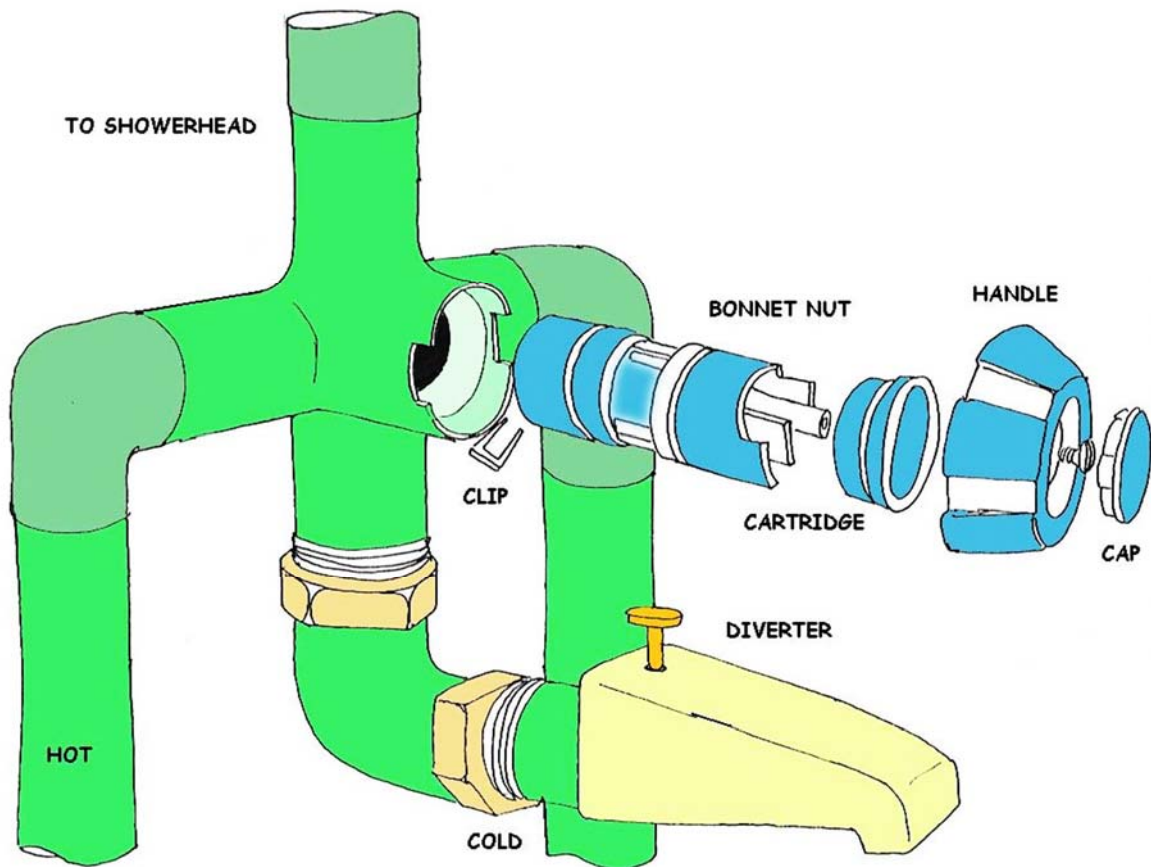

Repairing Double-Handled Faucets

If a faucet is leaking, a washer (for compression) or O-ring (for cartridge) probably needs to be replaced.

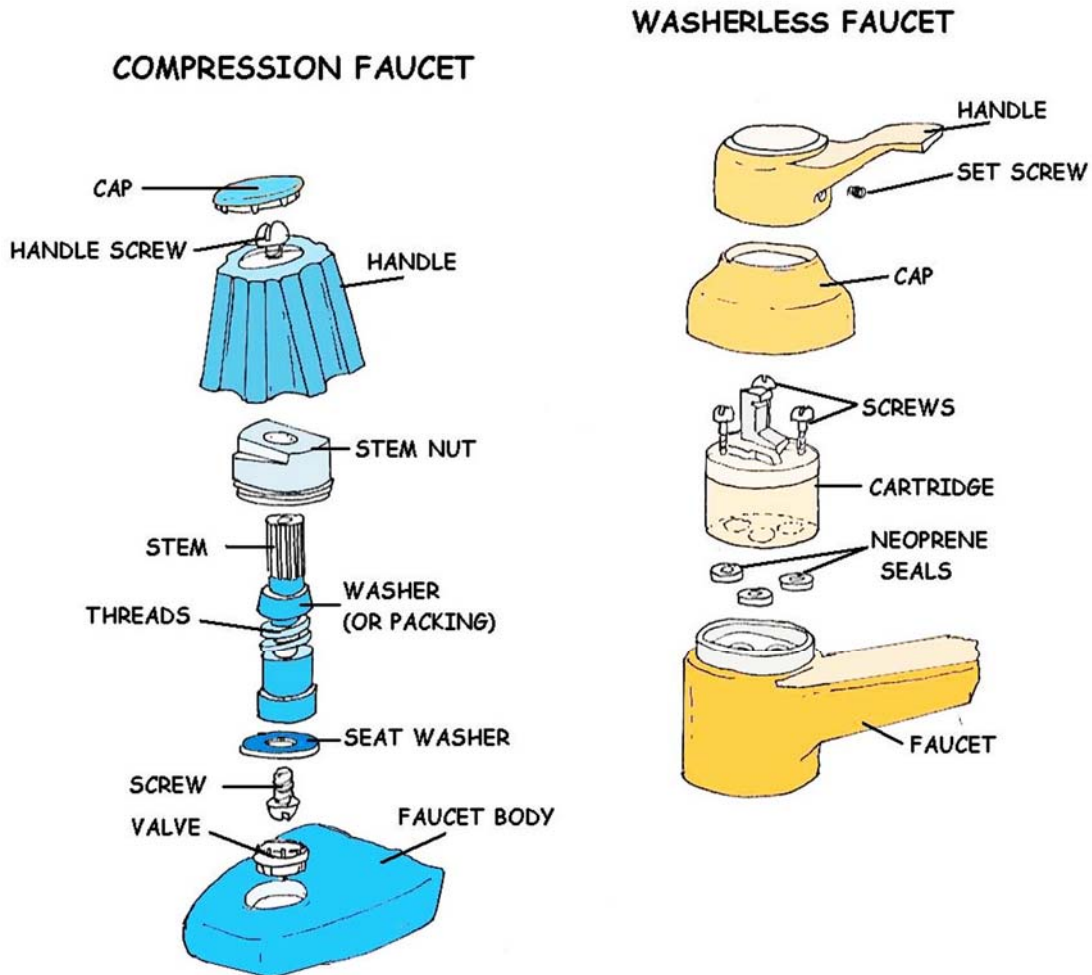

Pry off the handle's decorative cap to access the knob screw. Unscrew and remove the knob to expose the stem. Make sure the water is turned off. For a compression handle, loosen the "packing" nut holding the stem. Remove the stem, flip it over and check the condition of the washer and O-ring. Replace the washer and O-ring if they show any wear or fraying. A cartridge handle is repaired about the same way. Lift out the cartridge, check the O-rings and replace them as needed. As a last resort, replace the cartridge if the leak persists. Re-install the assembly, turn on the water and check for drips. If a compression faucet still leaks, the seat where the valve seals may need to be cleaned, or re-cut with a seat cutter tool.

To stop a leak around the handle, add a packing washer over the stem. If an old compression type handle still leaks, remove the packing nut and wind packing (a string gauze) around the nut to seal the assembly.

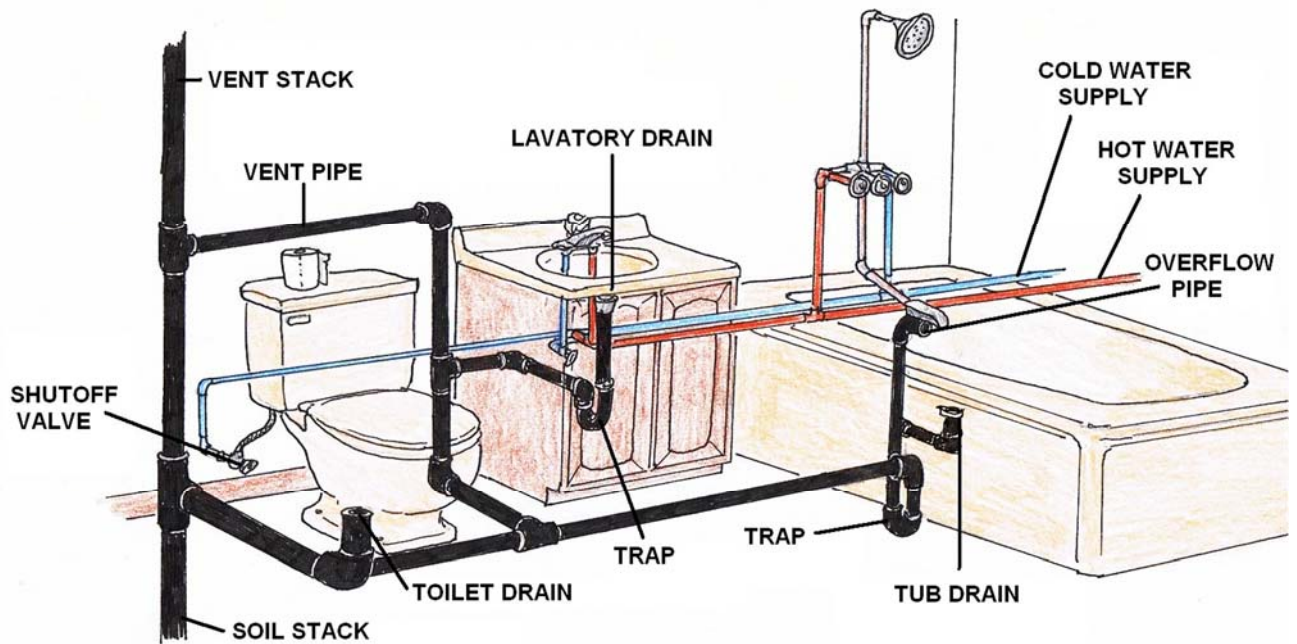

BASIC BATHROOM PLUMBING

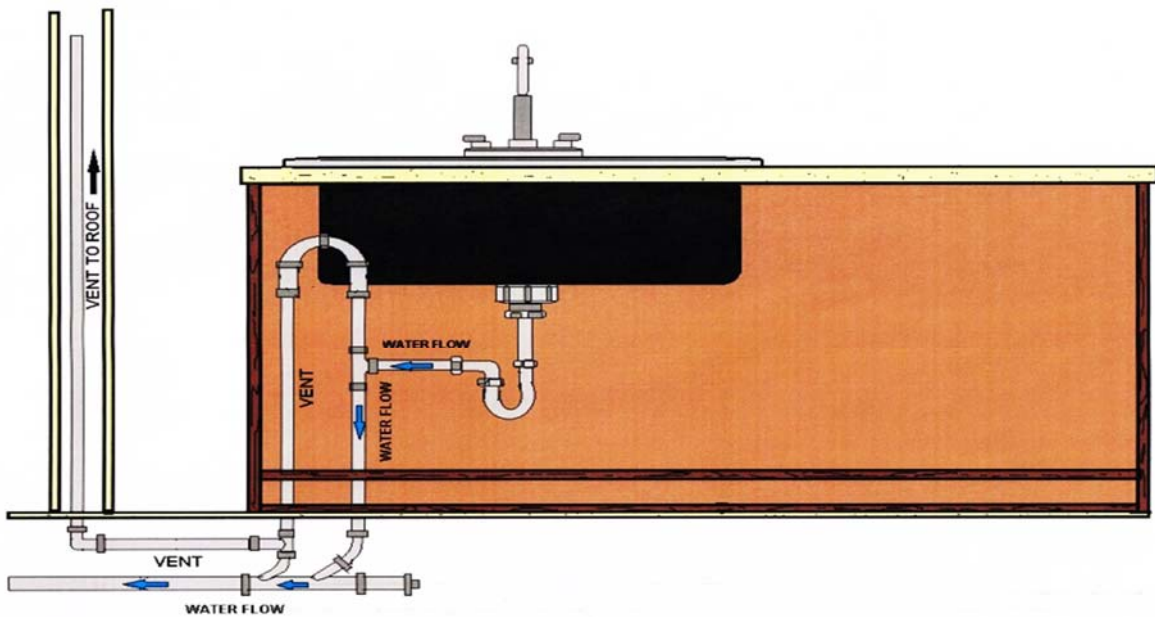

KITCHEN ISLAND PIPING

Fixing Ball-Type Faucets

A ball faucet can leak in several places: around the handle, spout, collar, or base. We'll describe how to repair the whole works. Yet, fixing your faucet may only involve one of these steps.



Locate the leak and shut off the water. Remove the set screw holding the handle. Using the kit's wrench, snug down the adjusting ring if it's loose and slowly turn the water back on to see if the leak has stopped.

If the ring is already tight or the leak persists, turn off the water and remove the adjusting ring.

Take off the plastic or ceramic cam piece and its seal that sets on the ball valve. Replace the seal if needed. Make a note of how the ball valve slot lines up with its small alignment pin then remove the ball.

Most models have two rubber seals and springs that set under the ball. Remove them, clean out any deposits and replace with new seals and springs.

On the outside of the housing, cut off the rubber O-rings and roll on new ones and re-install the faucet.

Repairing A Single-Handle Cartridge Faucet

After locating the leak and shutting off the water, pry off the faucet's top cap, remove the screw and lift off the handle piece.

Remove the lock nut and retaining clip holding the cartridge in place. Lift out the cartridge and inspect its seals. In most cases, the cartridge piece doesn't need replacing, but any worn or frayed seals should be replaced.

While the cartridge is out, inspect and replace the O-rings on the outside of the housing. Just cut them off and roll on new ones.

Re-insert the cartridge, align it as removed, and pop on the retaining clip. Fit the faucet back on and tighten down the lock nut. Re-position the handle, screw it down and put the cap back on.

General Care of Kitchen Sinks

Today, kitchen sink bowls come in many different materials. Although enameled cast iron remains an attractive and durable product, many people today are choosing bowls made of stainless steel, and other solid surface materials for their added durability and stain resistance.

Bowls are available in Corian, Moenstone, Swanstone, Surrell, and others. The important thing to remember is to follow the manufacturer's instructions pertaining to the material of which your bowl is constructed. With some of the solid surface materials, scratches can be removed when lightly sanded because the color goes throughout the thickness of the material.

To prolong the life and appearance of enameled cast iron sinks, clean the bowl immediately after use. Use a non-abrasive cleaner. Constant use of abrasive cleaners can eventually wear the finish down, making it much more porous and susceptible to stains. This can also happen with enameled, cast iron tubs over a long period.

Don't allow fruit or vegetable juices or cleaning acids to stand on surface. An acid-resisting sink will safely resist lemon, orange, and other citrus fruit juices, tomato juice, mayonnaise, and other vinegar preparations if these are not permitted to remain more than a few hours. A regular enamel finish is not impervious to acids.

Teas and coffee grounds will also stain enameled surfaces, if allowed to remain very long.

Photographic solutions are even more harmful to enamel, and the amateur photographer should not be allowed to use the sink, because a fixture once damaged in this way can never be corrected. When cleaning the sink, use hot water and soap. Water and soap are not as hard on the enameled finish as strong cleaning solutions like washing soda or a gritty abrasive. If a cleaner is used, it should be one that specifically states that it is non-abrasive.

Lavatories

The same precautions mentioned above for kitchen sink care pertain to lavatory bowls. Clean them often with hot water and soap. If a cleaner or cleanser is necessary, use one that is non-abrasive. Today, it is easy to eliminate the use of glass bottles and jars from the bathroom. This prevents the possibility of chipping the lavatory bowl if dropped. If acids or medicine spill on the surface, wash the spills immediately.

Bathtubs

Modern bathtubs and showers can be made from a myriad of materials ranging from the conventional enameled, cast iron and steel, to fiberglass, acrylic, and man-made materials such as cultured marble. Many one piece tub or tub and shower combination units are made from gel coated fiberglass or acrylic plastic.

Never use abrasives on any of these materials. They can cause scratches to the surface. Usually they will clean with hot water and soap.

If that is not sufficient, a cleaning product recommended by the manufacturer of the fixture, or your plumber, can be used to handle heavier cleaning tasks.

Fiberglass and Acrylic

With fiberglass and acrylic units, special polishes with no abrasives are available to protect their finishes by sealing the pores in the material, which makes subsequent cleaning easier. When decorating the bathroom or repairing something near the bathtub, place a heavy cloth over every inch of the bathtub surface so paint, falling tools, etc., will not mar or chip the enameled surface. Do not stand in the bathtub with shoes, as the nails and grit in the soles will scratch the enameled surface. Fiberglass and acrylic hubs should be cleaned with non-abrasive cleansers recommended by manufacturers.

Water Heaters

You can't get along without hot water. Therefore, take care of the source--the water heater. If you have a gas or electric water heater, keep the temperature dial setting at or below the suggested Factory Energy Savings Settings listed on the water heater. Above that mark means excessive wear on the water heater and the potential for scalding.

The burner of a gas-fired water heater is easily accessible and should be checked by your plumber periodically to keep it clear of dust or sediment. The flame at full fire should be a light to dark blue. If the flame is more orange or yellow, the gas pressure or air flow needs to be adjusted. You can keep your water bills low by tempering all hot water as it is used. Letting the hot water faucet run on and on wastes not only water but fuel as well. With all water heaters, plan your hot water needs and you'll be delighted with the savings you get



All domestic water heaters are required to be equipped with a relief valve as a safety feature to prevent damage from excessive pressure and temperature. There is always danger that this valve may become frozen or corroded from long disuse.

For this reason, it is advisable to trip the lever of this valve manually every two or three months to be sure it will operate freely if an emergency arises.

Note: The discharge will be hot water that will need to be contained in a pan or bucket or allowed to drain to a floor drain.

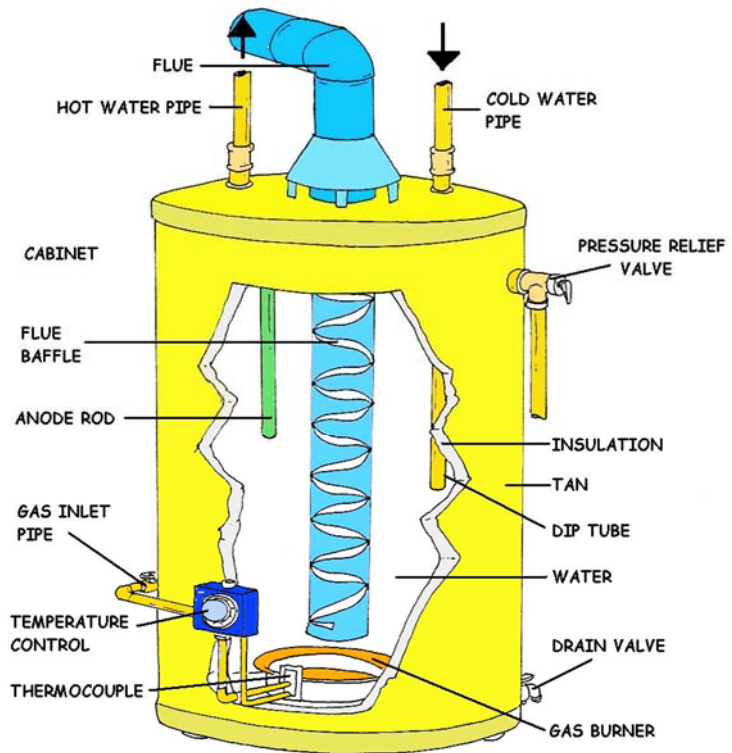

GAS WATER HEATER

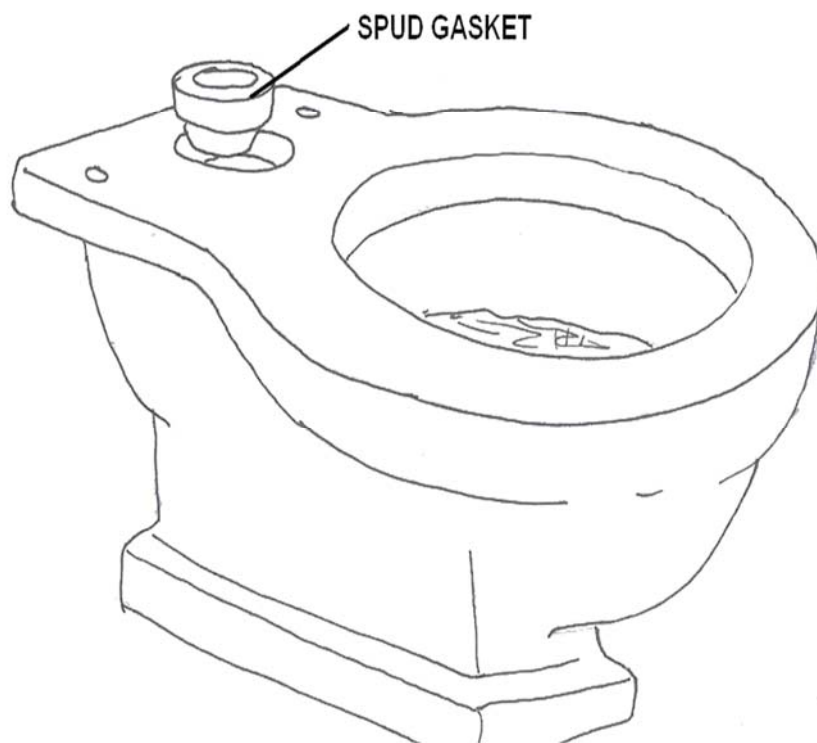
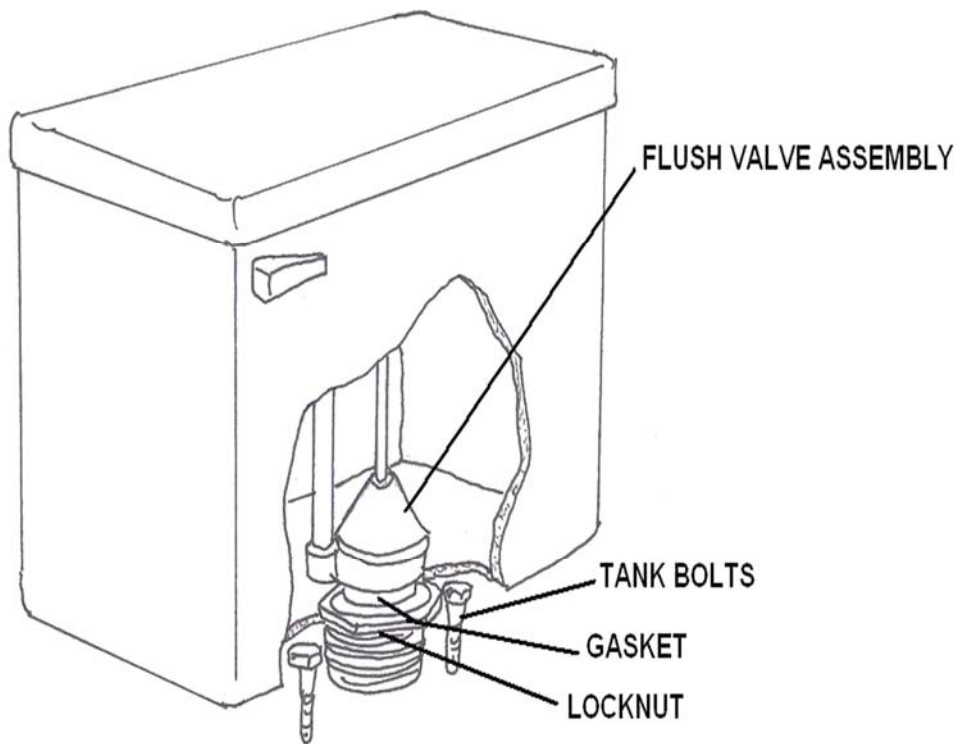

Water Closets (Toilets)

Closet tanks and bowls are made of vitreous china and are impervious to ordinary household acids. If something more than hot water and soap is needed to clean them, apply a non-abrasive powder or cleaner recommended by your plumber. Many good bowl cleaners are on the market today.

Most plumbers however, have found that the "blue water" continuous bowl cleaners tend to accelerate the deterioration of the rubber and neoprene parts in the tank, due to the chemicals they contain.

Seat bumpers should be replaced if worn. Defective bumpers may cause breakage of the seat or hinges.

Stains

Stains or moisture at the base of the closet bowl indicate that the joint or seal between the closet and its outlet have failed and should be reset immediately to prevent rotting of the floor, damage to the plaster of the ceiling below, and possible leakage of sewer gas into the home.

Types of Toilets

Water Closet Tanks

If water continues to run into the closet bowl after the toilet is flushed, it is obvious that some part of the mechanism is out of order.

When the tank has refilled, if water continues to seep into the bowl or if there is a low humming noise, this indicates leakage from the tank. This leakage can occur from either the supply valve or the improper seating of the rubber tank ball or (flapper) on the discharge opening.

A small amount of food coloring added to the tank water will help you determine whether the tank ball in the bottom of the tank is leaking. Add it to the water after the tank is filled. Watch for the coloring to seep into the toilet bowl, and if it does, the ball or flapper over the discharge opening is not water tight. If the rubber tank ball does not fit tightly over the discharge opening, a defective ball, irregular seat or bent lift wires may be responsible. If the ball is worn out, miss-shaped or has lost its elasticity and fails to drop tightly into the hollowed seat, it should be replaced with a new one. Sometimes the ball is covered with a slimy coating which can easily be wiped off.

To replace the ball, shut off the water supply (a stop is installed underneath the tank where the water may be conveniently shut off at this point) and empty the tank or place a stick under the ball float lever-arm to hold it up, thereby shutting off the intake cock and preventing the tank from refilling. Then unscrew the ball from the lower lift wire and attach a new ball of the same diameter as the old one. (Note: some old tank balls swell from age and absorption of water.)

If the collar or seat of the discharge opening is corroded or grit-covered, it should be scraped and sand-papered until it is smooth and forms a uniform bearing for the stopper.

Straighten or replace bent lift wires so that the ball drops squarely into the hollowed seat.

A leaky, waterlogged float ball holds the supply valve open and does not completely shut off the water. If the rod which connects the tank float to the supply valve has become bent, it may prevent the float from reaching its full height, thus leaving the valve open and allowing leakage. This rod should be straightened and a little oil applied to the lever joints to insure smooth action.

Sometimes the tank will not fill sufficiently or will fill to overflowing. These difficulties may be corrected without disturbing the supply valve by bending the rod attached to the tank float upward or downward. If the rod is bent upward, the water will rise higher in the tank, and if downward, the water level will be lowered.

An overflow tube or pipe is provided in the closet tank to take care of the water in case it should rise above its accustomed level which should be at least 3/4 of an inch below the top of the overflow. While there is not much danger of its becoming stopped up, it might be well to examine it occasionally to see that it is in working order.

If water rises to the top of the overflow pipe an adjustment or new fill-valve assembly is necessary.



Testing 1.6 gallon toilets against each other.
Toilet retrofit programs have save thousands of gallons of water.

How a Toilet Works

The toilet is essentially a **"trap"** just like the one under the kitchen sink but only larger (for obvious reasons). And like a trap, the fact that water is always present in the bottom (the bowl) it **"traps"** or prevents sewer gases from backing up into the house.



Below are a couple of the principles involved in how a toilet works:

- Water seeks its own level.
- A simple siphon
- Flush or Flood
- Momentum

Simply speaking, we **"flood"** a toilet to make it work.





When we press the handle on the tank (not shown here), the flapper valve is opened and the water stored in the tank is released into the bowl at a very fast rate causing the water level in the bowl to rise and overflow rapidly. The rising water seeks its own level and overflows down the trap creating a siphon that literally sucks the water out of the bowl.

The siphoning continues until the water level in the bowl falls below the lip at the bottom of the bowl.

When this happens air enters the drain path and **"breaks"** the siphon and the flush stops. But since the siphon created such momentum in the moving water the new level in the bowl is considerably lower than before the flush.



This is where the standpipe comes in. With the flapper valve closed, the tank starts to fill again and a separate tube directs water down into the standpipe directly into the bowl through a bypass under the flapper valve.

This filling of the bowl will stop automatically when the tank is filled.

If for some reason the tank float valve (*not shown here*) fails to shut off the water filling the tank, the water will continue to rise until it reaches the top of the standpipe which will drain the overflow from the tank into the bowl of the toilet.

Under these circumstances though, the toilet will not flush because the volume of water being discharged into it is minimal. It merely overflows in a trickle down the back end of the (trap) of the toilet.



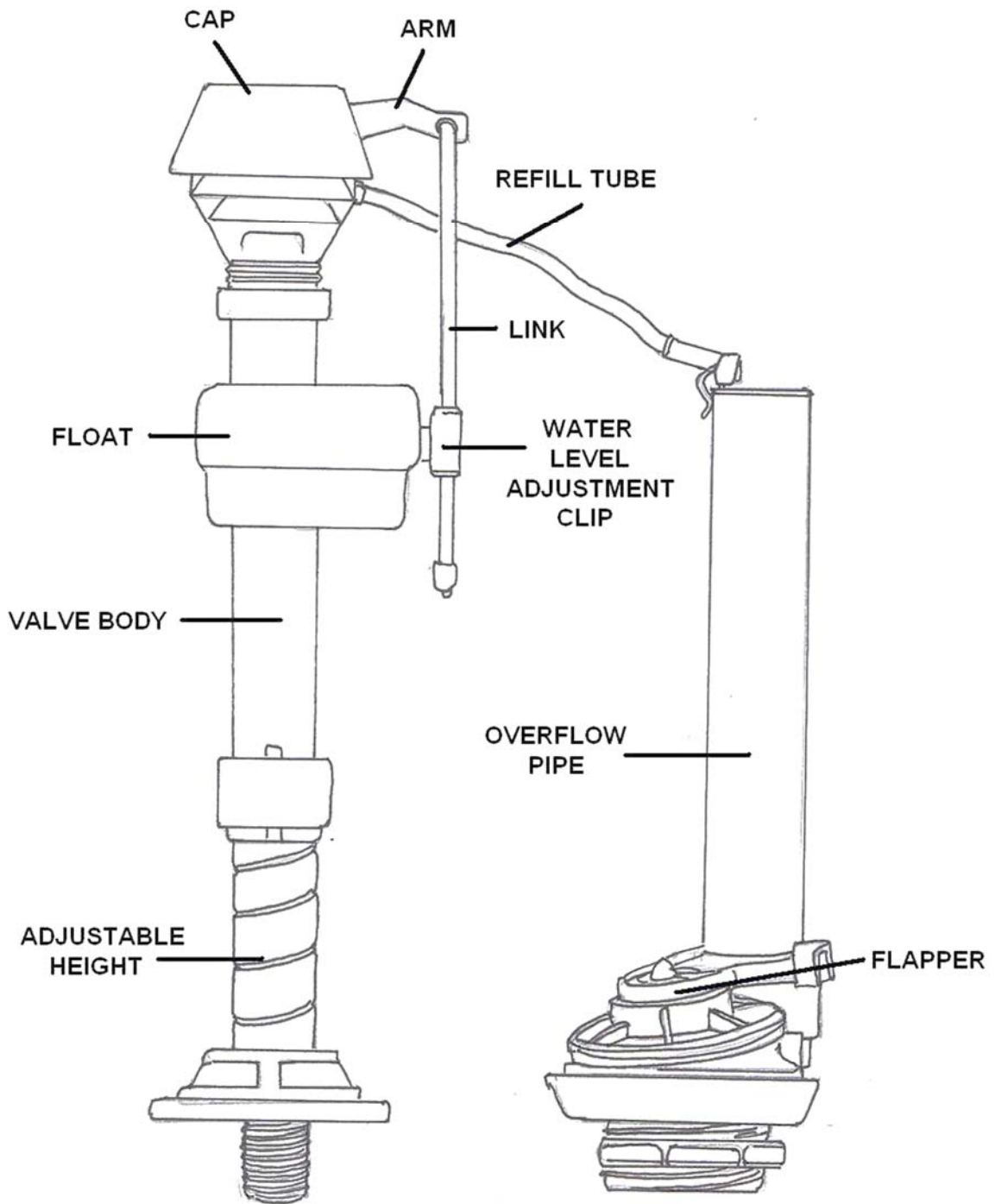

TOILET FLUSHING ASSEMBLY

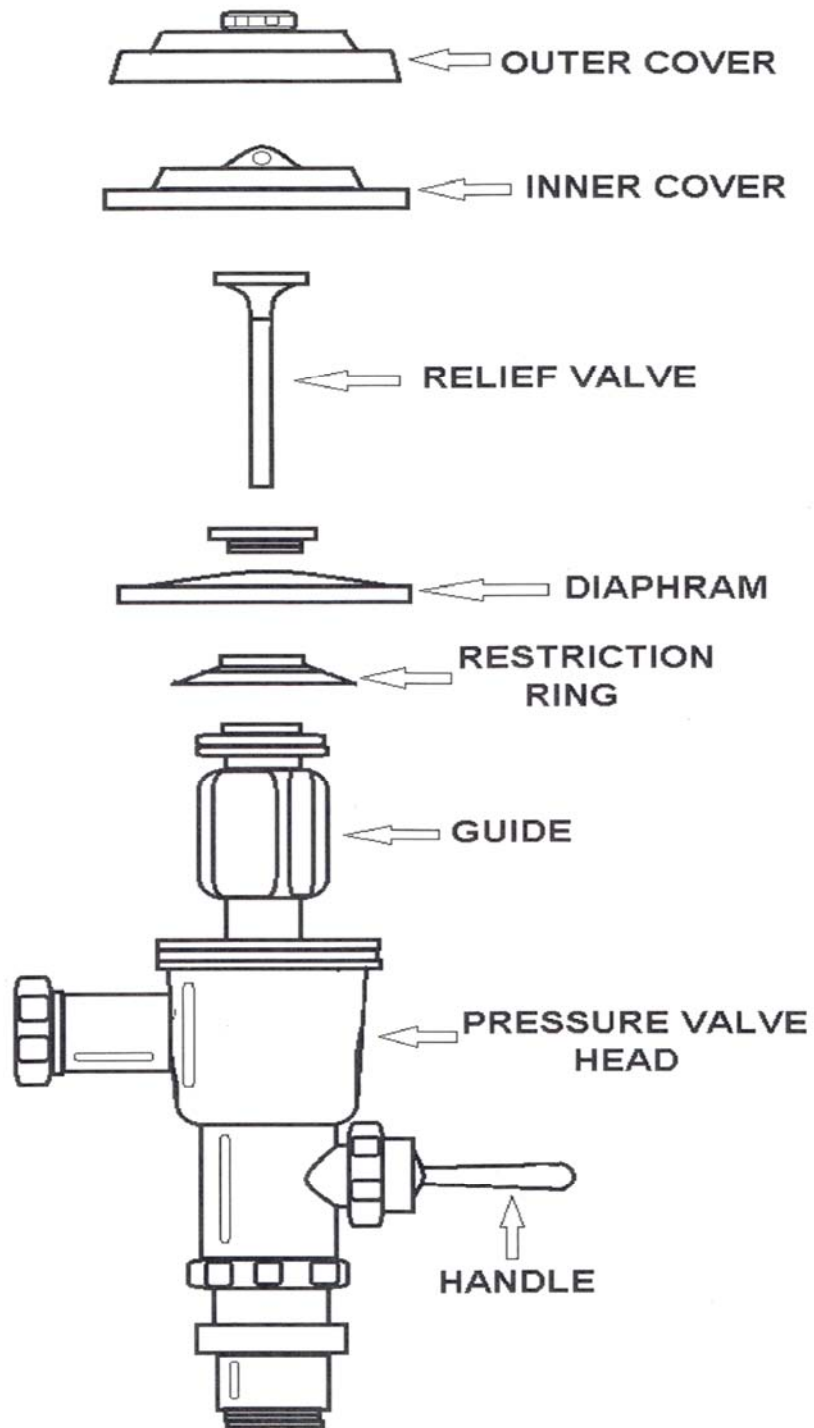

FLUSHOMETER

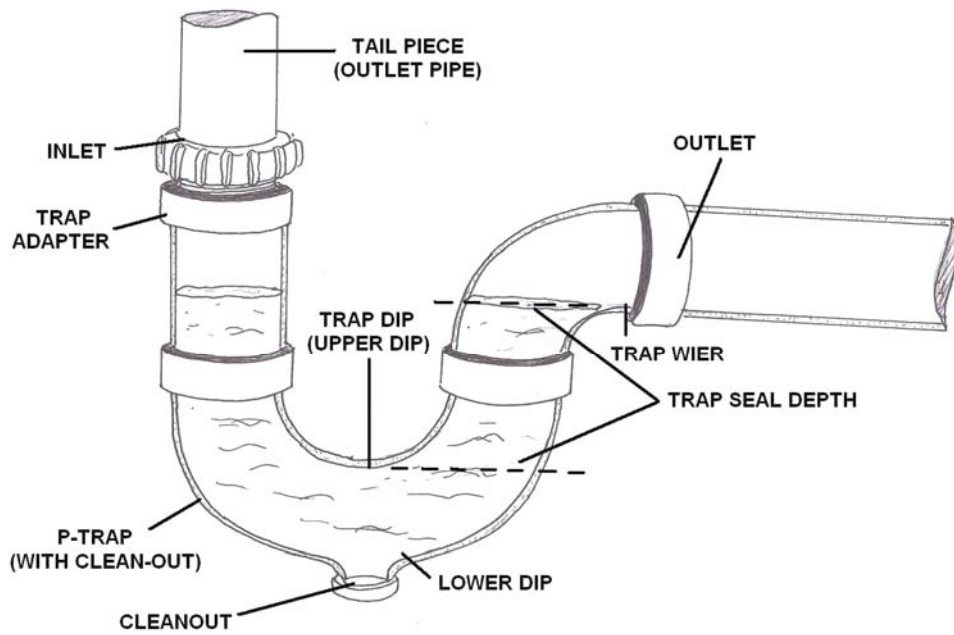
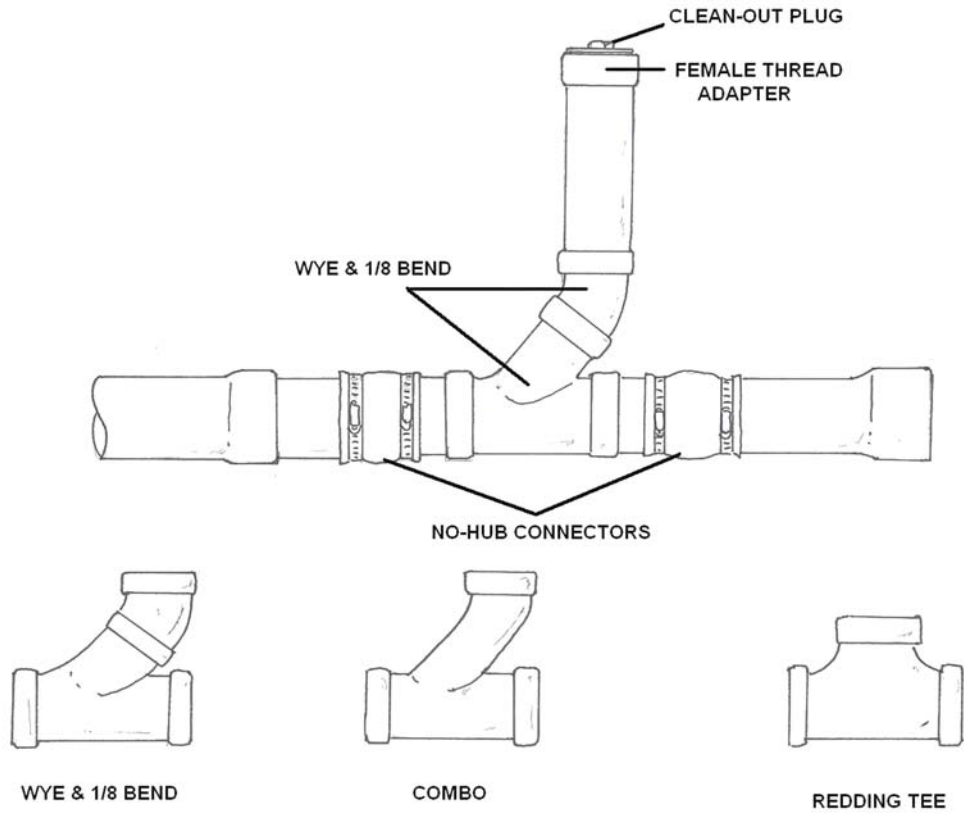

TRAP TERMINOLOGY

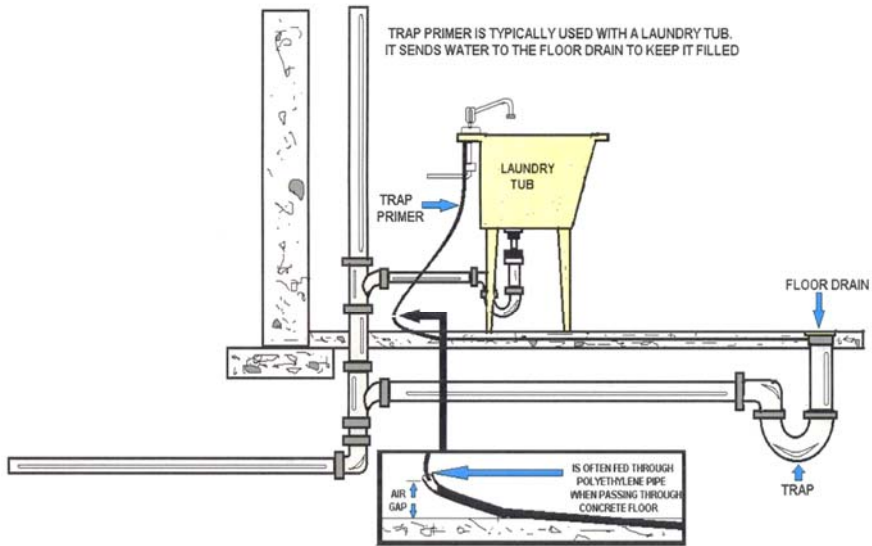

TRAP PRIMER

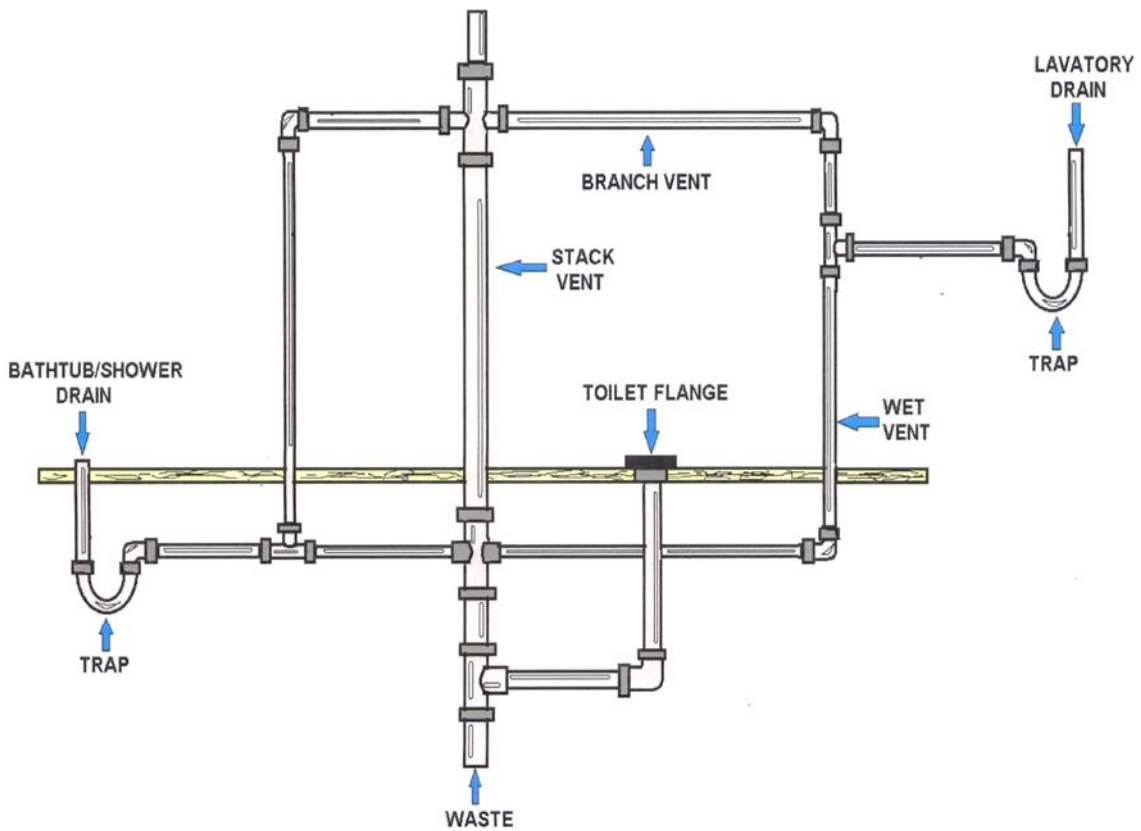

VENT TERMINOLOGY

Press Release

Town Installs Waterless Urinals

We haven't had much rain lately and need to think of ways to conserve water. Because of the current drought and social responsibility of saving our natural resources, the Town of Sunflower's Water Department is excited to announce the Waterless Urinal Retro-fit Pilot Program has begun. The Water Department has implemented this along with several other new water conservation methods and technologies to help reduce our daily water demand.

The Town has installed 17 of these completely waterless urinals in public facilities throughout the Town. These urinals are expected to save 750,000 gallons per year. This type of urinal replacement program is successful in 30 cities throughout Arizona.

Waterless urinals work completely without water. Waterless urinals can be easily installed to all restroom applications. This fixture saves up to 45,000 gallons of water and more per year per fixture. It greatly reduces typical urinal maintenance and improves restroom sanitation.

Waterless urinals eliminate and/or minimize these common problems:

Urinal Odors	Vandalism
Flush Valve Repairs	Line Encrustations
Low Water Pressure	Leaking Flush Valves
Costly Flush Sensors	Water & Sewer Costs
Stoppages and Overflows	Rest Room Shut Downs
High Demand on Septic Tanks	Mitigation for Water Usage

The Water Department will closely analyze and test these and other water conservation devices and hopefully install more devices throughout public facilities. Water saving devices, along with water conservation awareness are major components of the Town's Water Conservation Program.

HOW THEY WORK:

No-Flush urinals resemble conventional fixtures, and easily replace them. They install to the regular waste lines, but eliminate the flush water supply lines. Flush valves are eliminated as well; there are no handles to touch, no sensors, and no moving parts! The urinal bowl surfaces are urine repellent; urine is 99% liquid and its drainage is affected without flush water. Daily cleaning procedures are the same as for flushed urinals.

Bill Fields, Water Resource Specialist, "**After a balanced consideration the Waterless urinal seems to be a water conservation fixture whose time has come. It clearly reduces maintenance costs, and may do so dramatically and immediately for some installations.**"

The best part is an automatic savings of 1 - 3 gallons of water per usage, depending on the model of flush urinal you're replacing. "**In any new construction, or whenever you plan to replace a flush urinal, Waterless urinals should be given serious consideration and possibly be required in the near future.**"

You can come and see this new technology in action and get a "free" water saving kit at the Water Department.





Prepare for extensive wall damage when retrofitting to a waterless urinal. You may need to replace tiles and drywall. Notice the square box on the right hand side, this is a trap primer for the floor drain. The trap primer keep a small amount of water to keep the drain's trap wet to prevent sewer odors from coming up.



Shower Equipment

Some Plumbing Codes require the use of pressure balanced bath/shower valves to prevent scalding in new homes and during remodeling.

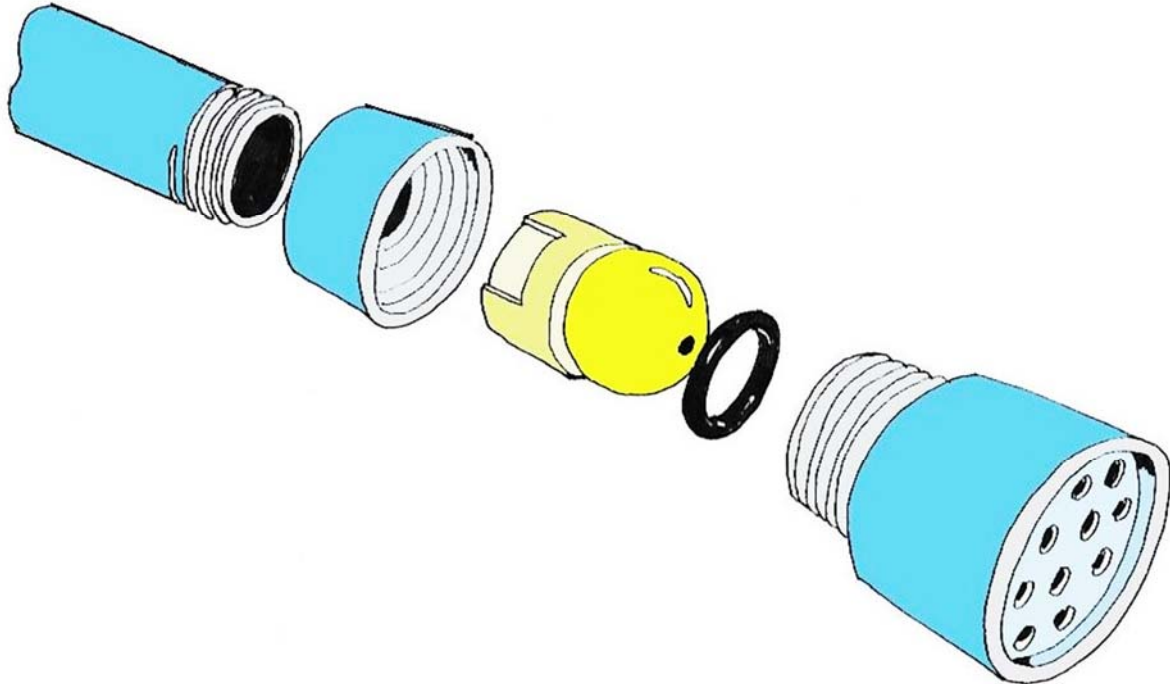

There is more potential for the scalding of a person showering if the pressure fluctuates. Most people aren't aware that young children and older persons can be scalded much sooner than adults. Lowering the water temperature at the water heater will minimize the potential danger at the tub spout or shower head and is the best preventive action which can be taken to prevent scalding. A small child doesn't have to soak in overly hot tap water to get scalded. Tragically, injury can happen literally in the blink of an eye. 150 degree water can scald in just 1/2 second, 140 degrees scalds in just 1 second, but it takes four minutes for water at 120 degrees to scald.

POINT OF CAUTION - - Never let a child bathe unattended, because of the danger of scalding and injury. In addition, always turn cold water on first, followed by the hot water until the desired temperature is achieved. That way, no one is exposed to straight hot water.

You need not rush to buy another shower head if the one you have suddenly gives off an uneven spray. It's probably clogged with mineral deposits which build up in the shower head and distort the shower stream. If the shower head holes are clogged, remove the face of the shower head, clean the back surface and free holes with a coarse needle. The latest shower heads on the market are all self-cleaning and need no such attention. The only positive preventive measure is investing in a water softener. When changing shower heads, wrap adhesive tape around the packing nut or pad the wrench jaws with a cloth so you won't mar the finish.

Chrome Plating

Chrome plating is a hard and durable finish that requires little attention except for the occasional washing with soap and water.

Salt air or other corrosive atmospheres have a destructive effect on chrome. Where chromium-plated fittings are exposed to these agents, it is important to wash them frequently. After they are washed and dried, it is advisable to apply a protective coating such as ordinary furniture wax.

Green spots may appear on chromium plating. If this happens, prevent the rust from spreading by scouring the spots with the same kind of powder which manufacturers recommend for enameled, cast iron fixtures. When the spots have been removed, apply a finish of wax.

Thawing Frozen Pipes

Frozen plumbing pipes, although inconvenient, do not constitute a calamity. The calamity may come if the pipes are thawed with a blow torch, and if the open flame or the torch is allowed to come too close to combustible material, such as insulation, wooden joists or flooring.

Another danger from the use of a torch arises when both ends of a pipe are clogged with ice and when the heat is applied in the center. The application of the heat of the torch at the center of the pipe is likely to cause the water to flash into steam, potentially causing an explosion with disastrous results for the user of the torch.

It is far better to adopt the slower and more conservative procedure of melting ice by the use of a blow dryer, or heat gun.

Preventing Frozen Pipes

Before the cold freezing weather sets in, make sure that all the garden hoses outside your home are disconnected. Failing to do so can cause not only the hose but also the hose bib to which it is connected, to freeze and be damaged.

This is especially important with anti-freeze hydrants. The hose must be disconnected to make the faucet freeze-proof. Failure to do so will trap water in the faucet body, which then can freeze. If the hose is disconnected, the anti-freeze faucet can properly drain, and this will prevent freezing.

Water pipes which are exposed to freezing temperatures or drafts should be covered with insulation. Whenever possible it is best to drain systems not being used in severely cold weather. Small water pipes will freeze quicker than will waste or sewer pipes.

Never leave a garage door open in severely cold weather if there is plumbing in the garage. The cold and draft can freeze water lines in minutes. Pipes located in unheated basements or garages should be insulated with a commercial covering. When pipes are laid underground they should be below the frost line to prevent freezing.

Noises in the Plumbing System

In designing the plumbing system for a new house, a plumbing contractor will endeavor to make it as noiseless as possible. Manufacturers of plumbing fixings are making every effort to reduce the noise connected with the operation of their equipment, and contractors have been very successful in eliminating much of the noise formerly associated with plumbing systems.

Because so much of the noise is due to water traveling at a high velocity, it follows that whatever can be done to reduce the velocity of the water will correspondingly reduce the noise in the system. It is for this reason that it is so important not to skimp on the size of the water supply piping. Larger pipe will not only provide a more adequate supply of water but will reduce noise.

There are three general types of noises found in some of the older plumbing systems. These are water hammer, whistling and chattering.

Water Hammer

Water hammer is the thump in the piping heard when faucets or valves are turned off abruptly.

There is no excuse for water hammer. It can usually be eliminated by the installation of an air chamber or short length of pipe in the wall where each supply pipe enters a plumbing fixture.

In some cases, however, the ordinary type of air chamber will not prevent water hammer. In such cases, special devices known as shock arrestors should be installed on the main line near the meter or as close as possible to the cause of the noise.

Sometimes water hammer is due not to the plumbing in the house in which it is heard but to a condition outside of the house, either along the water main or in a neighboring house. In such cases, skillful detective work by an experienced master plumber is necessary to ferret out the source of the trouble and to plan corrective methods.

Water hammer should not be permitted to go on indefinitely. The noise is only an audible symptom of what is going on in the piping. The piping is being subjected to the wear and tear of a multitude of shock waves. The result will be leaks in piping, tanks or fixtures unless the condition is corrected.

Chattering in the piping may be caused by loose pipes, by pipes rubbing against a metal projection, by worn faucet washers or looseness of other inside parts.

Whistling is caused by the speed of water flowing through piping which is usually too small. A pressure reducing valve will help as will a general straightening out of the plumbing system.

Whistling is most common at bends and tees in the pipe.

Draining Plumbing in a Vacant House

If your house is to be vacated during cold weather and the heating system turned off, follow this procedure:

Shut off the water supply at the main shut-off valve at the street. Then beginning with those on the top floor, open all faucets and leave them open. When water stops running from these faucets, open the cap on the main shut off valve in the basement and drain the remaining water into a pail or tub. Remember that this cap must be closed after the faucets have run dry or the house water supply will flow from this valve and flood the basement.

Remove all water in the traps under sinks, water closets, bathtubs, and lavatories by opening the clean out plugs at the bottom of traps and draining them into a pail. If no plugs are provided, use a force pump or other method to siphon the water out. Sponge all the water out of the water closet bowl. Clean out all water in the flush tank.

Fill all traps with a non-freezing solution such as mineral oil, windshield washing fluid or RV type anti-freeze.

Drain all hot water tanks. Most water tanks are equipped with a vented tube at the top which lets air in and allows the water to drain out the faucet at the bottom. Make sure all horizontal pipes drain properly.

Air pressure will get rid of trapped water in these pipes, but occasionally the piping may have to be disconnected and drained. To be safe, have your plumber check your entire plumbing system.

If your house is heated by hot water or steam, drain the heating pipes and boiler before leaving. Burners and pilots should be completely out and the main water supply turned off at the basement wall or street.

Draw off the water from the boiler by opening the draw-off valve at the lowest point in the system.

Open the water supply valve to the boiler so no water will be trapped above it. If you have a hot water system, begin with the highest radiators and open the air valve on each as fast as the water lowers. Every radiator valve must be opened on a one inch pipe system to release condensation.

Note: When you return home, refill all the systems **BEFORE** lighting the hot water heater or boilers.



Water Closet and Pedestal Urinal

Fixture connections between drainage pipes and water closets, floor outlet service sinks and pedestal urinals, and earthenware trap standards shall be made by means of brass, copper, hard lead, plastic, or iron flanges; caulked, soldered, screwed or solvent welded to the drainage pipe. Flanges of hard lead, plastic and iron flanges for no-hub or compression joints shall be secured to the floor. The connection shall be bolted, with a gasket, washer or setting compound, between the earthenware and the flange. The floor flange shall be set on an approved firm base. The use of putty or non-drying plumber's putty manufactured specifically for plumbing installation is acceptable.

Water Closets

a) Public Use.

1) Water closet bowls for public use shall be the elongated type and the seat shall be an antimicrobial plastic open-front seat. Exception: Water closet bowls for public use may have closed front seats provided the seat is encased with a continuous plastic sleeve capable of providing a clean surface for every user.

2) The activating handle, button or mechanism of the flush valve shall be at least 10 inches above the overflow rim of the bowl and not more than 44 inches above the floor.

3) In schools that are not licensed as day care centers or homes, water closets provided for the use of children under 5 years of age shall be of size and height suitable for children's use, either child or juvenile type.

4) Water closets designed for institutional use may be used in intensive care facilities and intensive coronary care facilities provided the water closet swings only horizontally and has an integral trap. A water closet flushometer shall be used to flush the fixture. The plans and specifications shall be submitted to the Department for approval prior to installation, and such approval shall be in writing from the Department provided the above requirements are met.

b) Water Closet Tanks. Water closet tanks shall have a volume sufficient to properly flush the water closet bowls with which they are connected.

c) Ball cocks. Ball cocks for flush tanks shall be of the anti-siphon type, properly installed, and have a provision for trap refill.

d) Flushing Device. The flush valve seat in all water closet tanks shall be 1 inch or more above the flood level rim of the water closet bowl, with the exception of one-piece water closets.

e) Flushometer Valve. Flushometer valves shall comply with ANSI/ASSE 1037-1990. Flushometer valves shall be installed so that they are readily accessible for repair. When the valve is operated, it shall complete the cycle of operation automatically, opening fully and closing completely under the service pressure. At each operation the valve shall deliver water in sufficient volume and at a rate that will thoroughly flush the

fixture and refill the fixture trap. Means shall be provided for regulating flush valve flow. Protection against backflow shall be provided by an approved vacuum breaker installed on the discharge side of the flushing valve. The bottom of the vacuum breaker, or the critical level line shown on the vacuum breaker, shall be at least 4 inches above the overflow rim of the bowl (see Section 890.1140(a) and (b)). Not more than one water closet shall be served by a single flushometer valve.

f) Seats. Water closets shall be equipped with seats of smooth non-absorbent material. All seats of water closets provided for public use shall be an antimicrobial plastic material and an open-front style, except closed-front seats may be provided if the seat is encased with a continuous plastic sleeve ensuring a clean surface for every user. No water closet seat shall be more than 1½ inches thick.

g) A flushometer tank (or pressurized flushometer valve in accordance with ANSI/ASSE 1037-1990) shall be used only with a water closet bowl specifically designed for that type tank/flushing device (i.e., in accordance with ASME/ANSI A112.19.2M-1998) and where the flow pressure at the fixture meets the manufacturer's minimum recommendations.

h) Water closets which rely on substances other than water for proper operation shall comply with requirements of the Private Sewage Disposal Code (77 Ill. Adm. Code 905). Privies and chemical toilets shall not be used inside any building.

i) Bidet. A bidet shall be equipped with hot and cold, tempered and cold, or tempered water only. An atmospheric vacuum breaker shall be installed on the discharge side of the flushing valve. The bottom of the vacuum breaker, or the critical level line shown on the vacuum breaker, shall be at least 4 inches above the overflow rim of the bidet.

j) Prohibited Water Closets. Hopper-style water closets and water closets with concealed couplings or submerged side inlets are prohibited.

Urinals

a) Automatic Flushing Tank.

1) Flushing tanks shall be used for washout urinals only. Tanks flushing more than one (1) urinal shall be automatic, shall provide a sufficient volume of water to flush all urinals simultaneously, and shall flush at least four (4) times per hour. One automatic flushing tank may serve no more than three (3) washout urinals.

2) Float Valves. Float valves or ball cocks, if provided for flushing tanks, shall be of the anti-siphon type and of sufficient capacity to refill the trap.

b) Urinal Flush Valves. No valve shall be used to flush more than one (1) blow-out, siphon-jet or pedestal urinal. One (1) properly sized automatic flush valve may serve more than one (1), but not more than a battery of three (3) washout urinals, and shall flush at least four (4) times per hour. The water supply line to each urinal flush valve shall be as required by the manufacturer, but not less than three-fourths (3/4) inch. Protection against backflow shall be provided by an approved vacuum breaker.

- c) Trough urinals are prohibited.

Strainers and Fixture Outlets

- a) **Strainers.** All plumbing fixtures other than water closets, urinals with integral traps, and any sink outlet having a disposal unit shall be provided with a strainer. A pop-up waste shall be considered a strainer.
- b) **Bathtubs - Waste Outlets.** The waste outlet for a bathtub shall have a strainer or stopper and shall have an outlet at least one and one-half (1 1/2) inches in diameter.

Lavatories

- a) **Waste Outlets.** Wastes shall have a strainer or stopper and have a waste outlet at least 1¼ inches in diameter.
- b) **Lavatory Faucets.** All lavatory faucets shall have air gaps.
- c) **When metering faucets are located on lavatories in public restrooms, they shall be adjusted to remain open for a minimum of 10 seconds, and shall comply with the water consumption requirements of ASME/ANSI 112.18.1-2000. Metering faucets shall be designed for hot and cold, tempered and cold, or tempered water only.**
- d) **Fixture Calculation.** Eighteen lineal inches of wash sink or 18 inches of a circular basin, when provided with water outlets for such space, shall be considered equivalent to one lavatory.
- e) **Water Temperature.** All lavatory faucets for public use shall be provided with an automatic safety water mixing device to prevent sudden unanticipated changes in water temperature or excessive water temperatures. The automatic safety water mixing device shall comply with ANSI/ASSE 1016-1996 or 1017-1998 in accordance with Section 890.210, and shall be adjusted to a maximum setting of 110°F, at the time of installation. Exception: Units constructed in accordance with Section 890.1220(a)(10)(B) may be used in lieu of an automatic safety water mixing device to provide hot or tempered water to public lavatories.

Shower Receptors and Compartments

- a) **Shower Installation.** All shower compartments, except those built directly on a slab floor or having receptors constructed of precast stone, terrazzo, concrete, molded stone, molded fiberglass, or an equally durable material such as cultured stone or synthetic stone, shall have a lead, copper, ABS, PVC or fiberglass shower pan. All sides of the shower pan shall turn up at least 2 inches above the finished shower floor level. Precast molded receptors shall have a minimum ¼ inch thick flange. Traps shall be constructed so that the pan is fastened to the trap at the seepage entrance, making a water-tight joint between the pan and the trap. Shower receptacle waste outlets shall be at least 2 inches in diameter and have a removable strainer.
- b) **Water Temperature Safety.** All shower compartments and shower-bath combinations shall be provided with an automatic safety water mixing device to prevent

sudden unanticipated changes in water temperature or excessive water temperatures. The automatic safety water mixing device shall comply with ANSI/ASSE 1016-1996, in accordance with Section 890.210, and be designed with a maximum handle rotation limit/stop, or comply with ASSE 1017-1998, in accordance with Section 890.210. The automatic safety water mixing device shall be adjusted to a maximum setting of 115° F at the time of installation. The temperature of mixed water provided to multi-shower units or gang showers shall be controlled by a master automatic safety water mixing device or the mixed water temperature for such showers shall be individually regulated by automatic safety mixing valves for each shower unit. A hot water heater thermostat shall not be an acceptable alternative water temperature control device.

c) Dimensions. Single family shower compartments or stalls shall have at least 1,024 square inches outside dimension (O.D.) floor area and shall be at least 32 inches in shortest outside dimension. All other shower compartments or stalls shall have no less than 1,296 square inches outside dimension floor area and shall be at least 32 inches in shortest outside dimension.

d) Materials. Shower walls shall be constructed of durable, smooth, non-absorbent, non-corrosive, and waterproof materials, such as fiberglass, enameled metal, plastic sheeting, etc. All shower compartments or stalls shall have a slip resistant floor (bottom) surface.

e) Public or Institution Showers. Floors of public shower rooms shall be drained so that no waste water from any bather will pass over areas occupied by other bathers. This will not prohibit the use of column showers.

Sinks

a) Waste Outlets. Kitchen sinks shall be provided with waste outlets at least 1½ inches in diameter. Other special purpose sinks such as bar sinks, lab sinks, and dipper wells may have smaller waste outlets. Waste outlets shall be of the flat or basket (cup) strainer type.

b) Food Grinders. Sinks in which food grinders are installed shall have a waste opening inlet for the food grinder at least 3½ inches in diameter.

c) No special purpose sink shall be substituted for kitchen purposes.

Food Waste Disposal Units

a) Installation. Food waste disposal units shall be trapped separately from any other fixture or compartment, shall be connected directly to the sanitary drainage system, and shall be properly vented. Dishwashers shall not discharge into food waste disposal units. Units may have either automatic or hand-operated water supply control.

b) Commercial-Type Grinders. Commercial-type food grinders shall be provided with a waste line at least 2 inches in diameter.

Drinking Fountains

- a) Design and Construction. Drinking fountains shall conform to the standard Specifications for Drinking Fountains. No modification of the mouth guard or nozzle shall be made.
- b) Protection of the Water Supply.
 - 1) All drinking fountain nozzles, including those which may at times extend through a water surface, with an orifice not greater than $\frac{7}{16}$ or 0.440 of an inch diameter or 0.150 square inches area, shall be placed so that the lower edge of the nozzle orifice is at an elevation at least $\frac{3}{4}$ of an inch above the flood level rim of the receptacle.
 - 2) The $\frac{3}{4}$ inch elevation shall also apply to nozzles with more than one orifice, provided that the sum of the area of all orifices shall not exceed the area of a circle $\frac{7}{16}$ of an inch in diameter or shall not exceed 0.150 square inches area.
 - 3) The nozzle shall be set at an angle from vertical such as to prevent the return of water in the jet to the orifice.
- c) Material. The fountain shall be constructed of impervious materials such as vitreous china, porcelain, enameled cast iron, stainless steel, or other metals or stoneware.
- d) Flow Regulator. The water supply for the drinking fountain shall be provided with an adjustable valve fitted with a loose key stop or an automatic valve regulating the rate of flow of water through the fountain so that the valve manipulated by the user of the fountain will merely turn the water on or off.
- e) Installation and Location. Drinking fountains shall not be installed as an integral part of or connected to any other plumbing fixture, such as a lavatory or sink, nor shall a drinking fountain be installed in a restroom or toilet room, except those in correctional facilities.
- f) Substitution. Whenever a drinking fountain is required by this Part, bottled drinking water or a water dispensing faucet (water station) may be substituted for a drinking fountain, provided drinking water is accessible to the public.

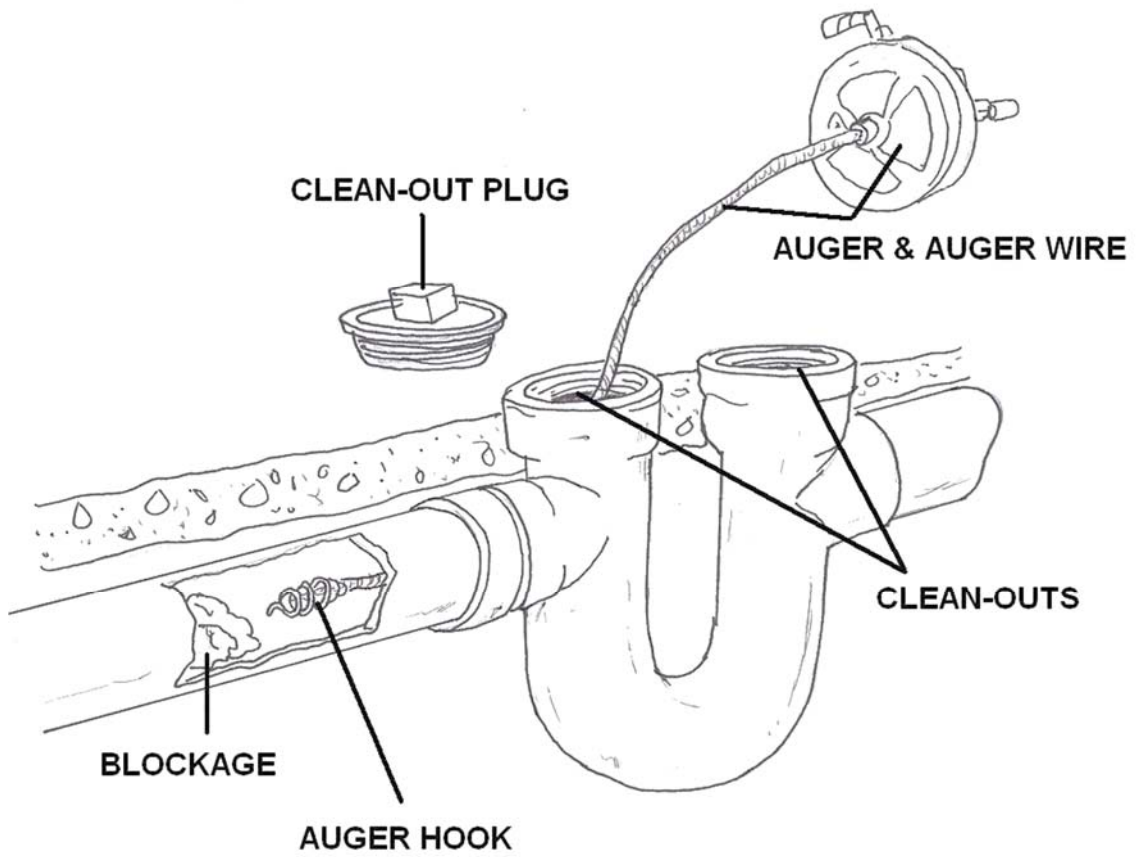

Collection System Diagrams

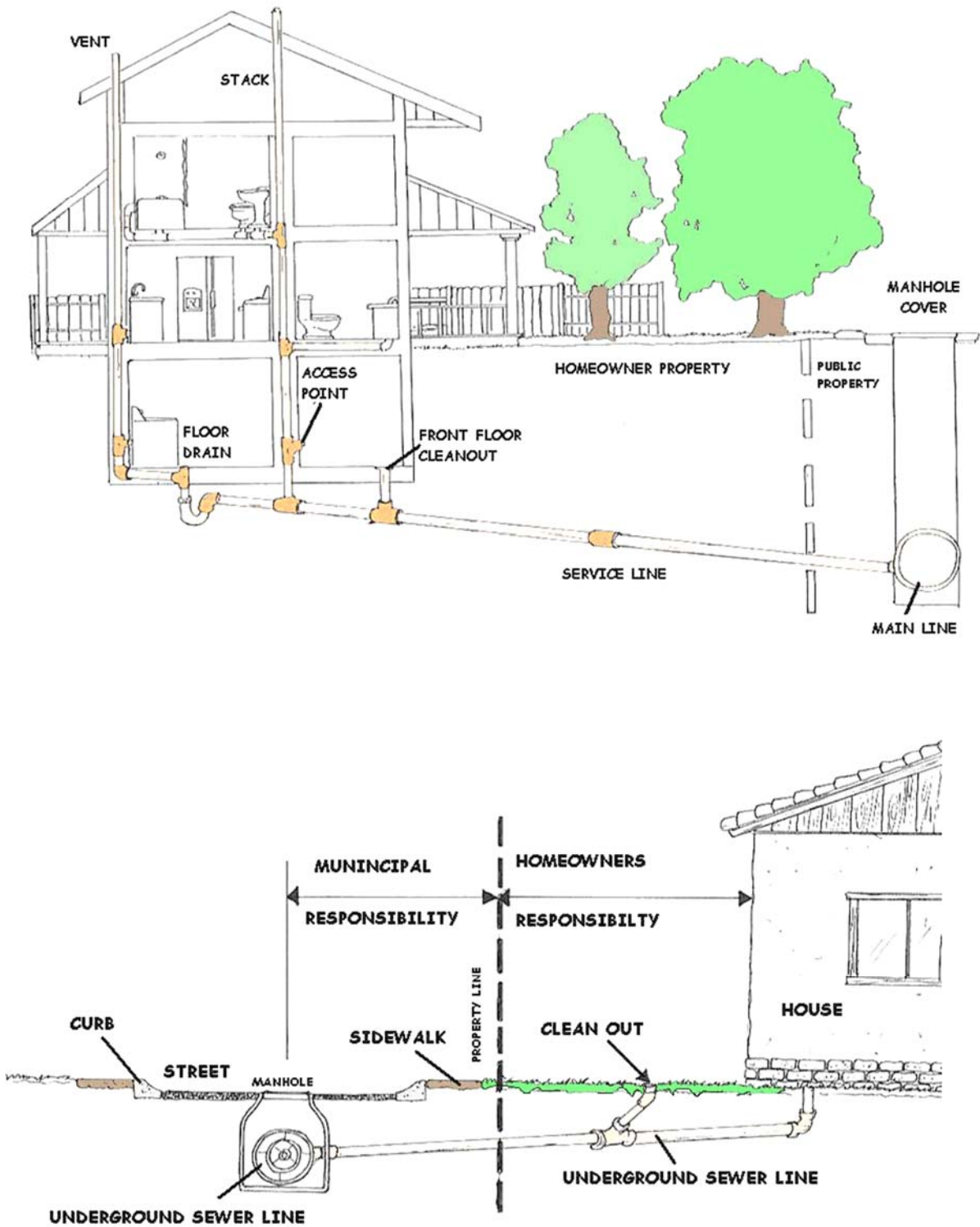

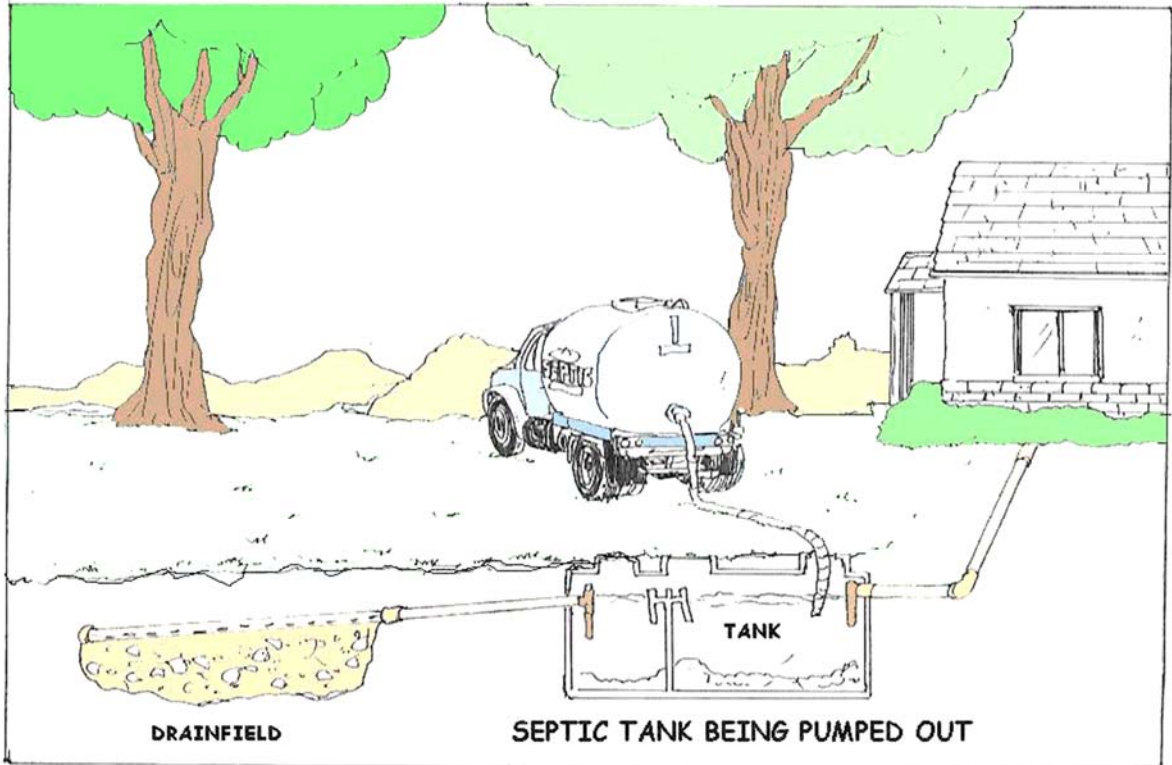
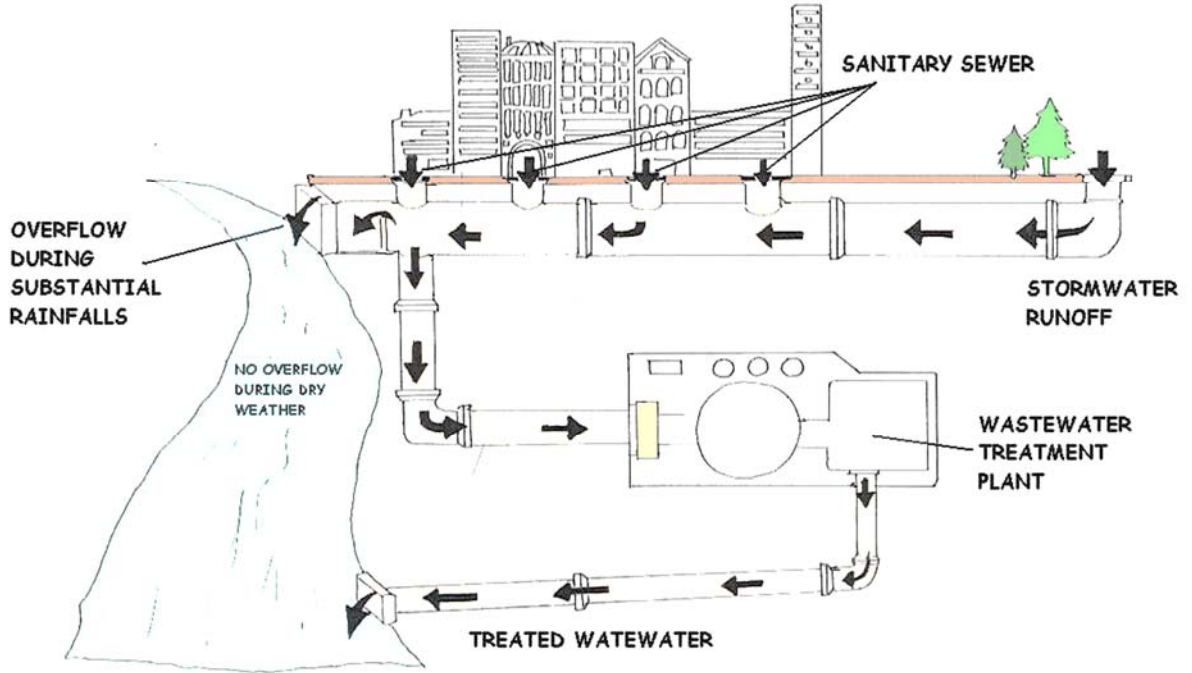

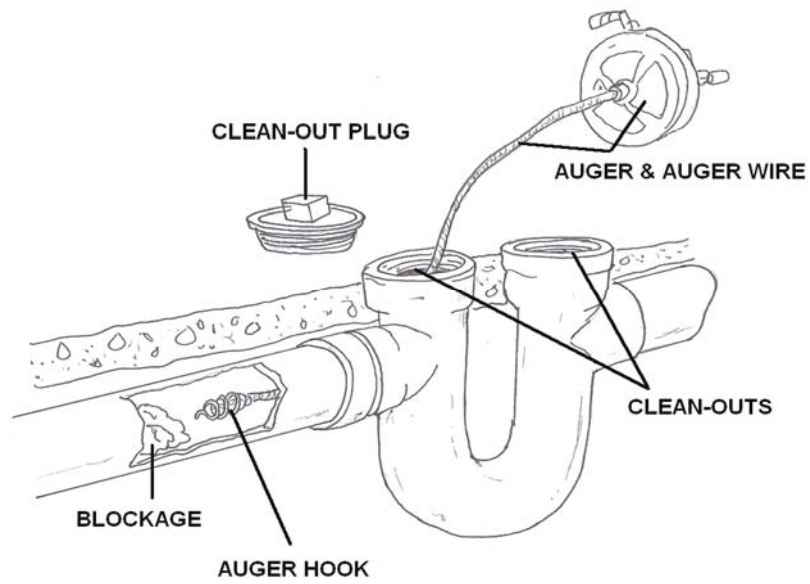
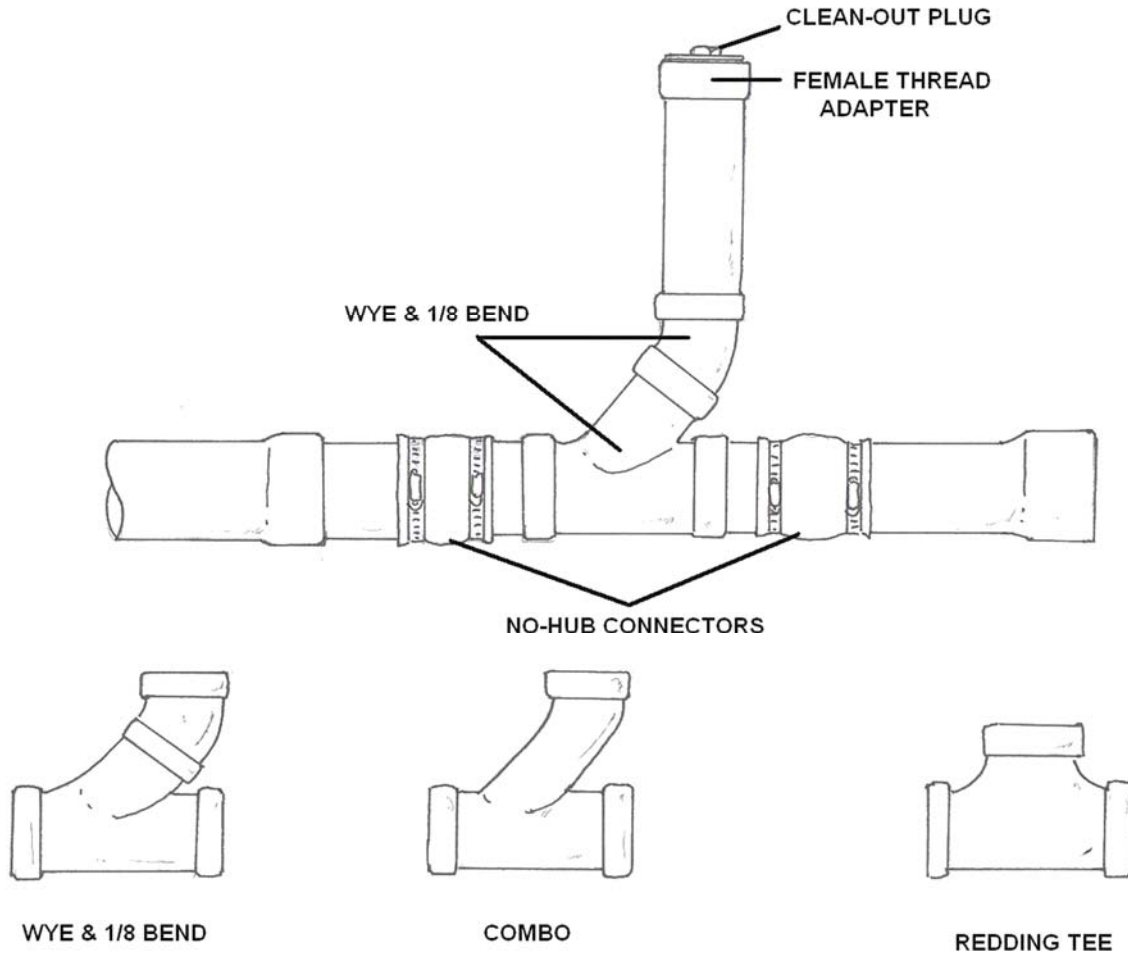

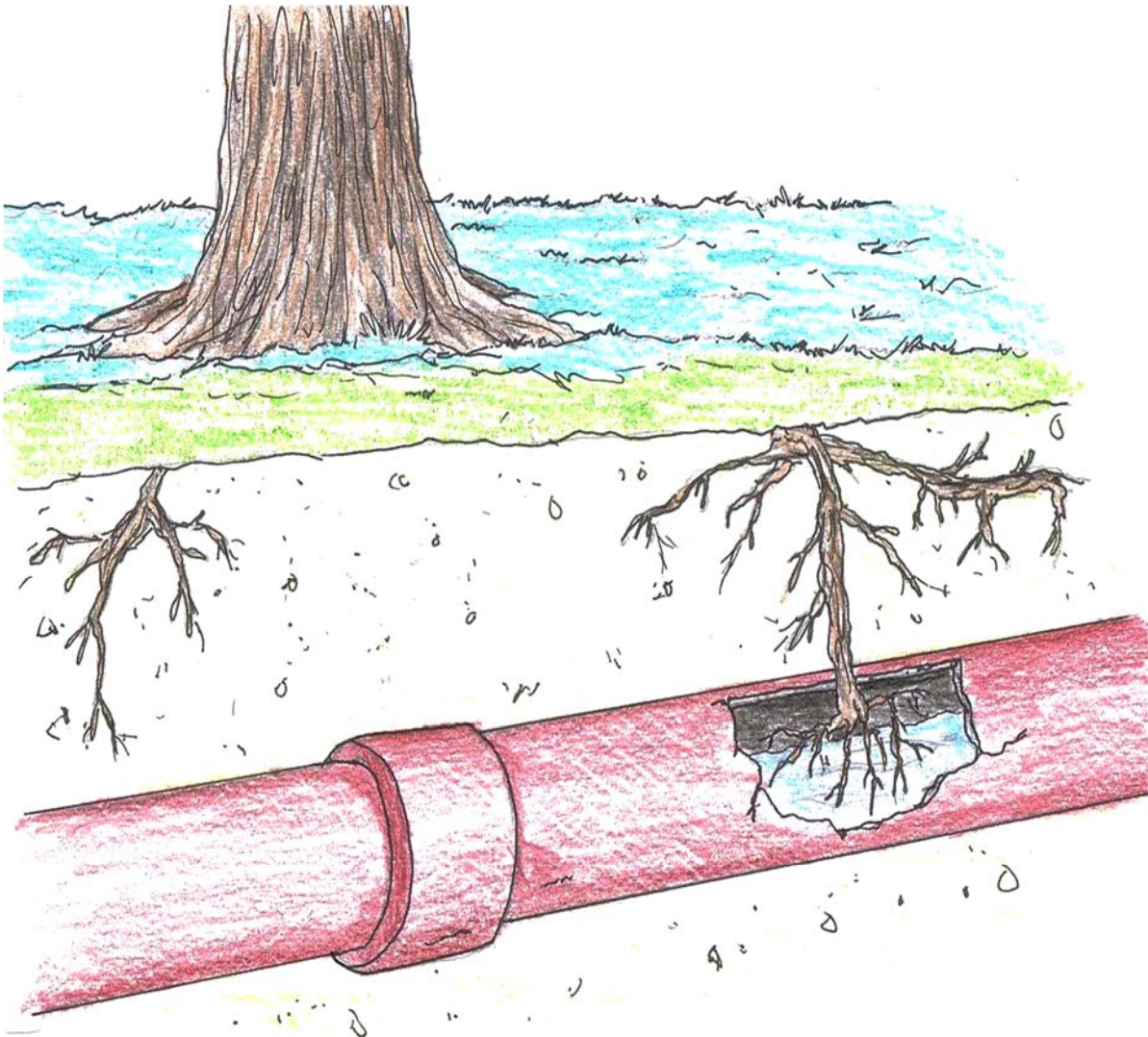

ROOTS INFILTRATING SEPTIC SYSTEM PIPING

Understanding Gravity Sanitary Sewers

A Sanitary Sewer has Two Main Functions:

- To convey the designed peak discharge.
- Transport solids so that the deposits are kept at a minimum.

Sanitary sewers are designed to transport the wastewater by utilizing the potential energy provided by the natural elevation of the earth resulting in a downstream flow. This energy, if not designed properly, can cause losses due to free falls, turbulent junctions, and sharp bends. Sewer systems are designed to maintain proper flow velocities with minimum head loss. However, higher elevations in the system may find it necessary to dissipate excess potential energy.

Design flows are based on the quantity of wastewater to be transported. Flow is determined largely by population served, density of population, and water consumption. Sanitary sewers should be designed for peak flow of population. Stormwater inflow is highly discouraged and should be designed separate from the sanitary system.

Gravity-flow sanitary sewers are usually designed to follow the topography of the land and to flow full or nearly full at peak rates of flow and partly full at lesser flows. Most of the time the flow surface is exposed to the atmosphere within the sewer and it functions as an open channel. At extreme peak flows the wastewater will surcharge back into the manholes. This surcharge produces low pressure in the sewer system.

In order to design a sewer system, many factors are considered. The purpose of this topic is to aid in the understanding of flow velocities and design depths of flow. The ultimate goal for our industry is to protect the health of the customers we serve. This is achieved by prevention of sewer manhole overflows.

Sewer System Capacity Evaluation - Testing and Inspection

The collection system owner or operator should have a program in place to periodically evaluate the capacity of the sewer system in both wet and dry weather flows and ensure the capacity is maintained as it was designed. The capacity evaluation program builds upon ongoing activities and the everyday preventive maintenance that takes place in a system. The capacity evaluation begins with an inventory and characterization of the system components. The inventory should include the following basic information about the system:

- Population served
- Total system size (feet or miles)
- Inventory of pipe length, size, material and age, and interior and exterior condition as available
- Inventory of appurtenances such as bypasses, siphons, diversions, pump stations, tide or flood gates and manholes, etc., including size or capacity, material and age, and condition as available
- Force main locations, length, size and materials, and condition as available
- Pipe slopes and inverts
- Location of house laterals - both upper and lower

The system then undergoes general inspection which serves to continuously update and add to the inventory information.

Capacity Limitations

The next step in the capacity evaluation is to identify the location of wet weather related SSOs, surcharged lines, basement backups, and any other areas of known capacity limitations. These areas warrant further investigation in the form of flow and rainfall monitoring and inspection procedures to identify and quantify the problem. The reviewer should determine that the capacity evaluation includes an estimate peak flows experienced in the system, an estimate of the capacity of key system components, and identifies the major sources of I/I that contribute to hydraulic overloading events.

The capacity evaluation should also make use of a hydraulic model. This model will help identify areas that need to alleviate capacity limitations.

Short and long term alternatives to address hydraulic deficiencies should be identified, prioritized, and scheduled for implementation. A sewer inspection is an important part of a sewer system capacity evaluation and determining your options or alternatives.

Flow Monitoring

Fundamental information about the collection system is obtained by flow monitoring. Flow monitoring provides information on dry weather flows as well as areas of the collection system potentially affected by I/I. Flow measurement may also be performed for billing purposes, to assess the need for new sewers in a certain area, or to calibrate a model.

There are three techniques commonly used for monitoring flow rates:

- (1) permanent and long-term,
- (2) temporary, and
- (3) instantaneous.

Permanent installations are done at key points in the collection system such as the discharge point of a satellite collection system, pump stations, and key junctions. Temporary monitoring consists of flow meters typically installed for 30-90 days. Instantaneous flow metering is performed by collection system personnel, one reading is taken and then the measuring device is removed.

The collection system owner or operator should have a flow monitoring plan that describes their flow monitoring strategy, or should at least be able to provide the following information:

- Purpose of the flow monitoring
- Location of all flow meters
- Type of flow meters
- Flow meter inspection and calibration frequency

Flow Monitoring Plan

A flow monitoring plan should provide for routine inspection, service, and calibration checks (as opposed to actual calibration). In some cases, the data is calibrated rather than the flow meter. Checks should include taking independent water level (and ideally velocity readings), cleaning accumulated debris and silt from the flow meter area, downloading data (sometimes only once per month), and checking the desiccant and battery state. Records of each inspection should be maintained.

Flow Measurements

Flow measurements performed for the purpose of quantifying I/I are typically separated into three components: base flow, infiltration, and inflow. Base flow is generally taken to mean the wastewater generated without any I/I component. Infiltration is the seepage of groundwater into pipes or manholes through defects such as cracks, broken joints, etc. Inflow is the water which enters the sewer through direct connections such as roof leaders, direct connections from storm drains or yard, area, and foundation drains, the holes in and around the rim of manhole covers, etc. Many collection system owners or operators add a third classification: rainfall induced infiltration (RII). RII is stormwater that enters the collection system through defects that lie so close to the ground surface that they are easily reached. Although not from piped sources, RII tends to act more like inflow than infiltration.

In addition to the use of flow meters, which may be expensive for a small owner or operator, other methods of inspecting flows may be employed, such as visually monitoring manholes during low-flow periods to determine areas with excessive I/I. For a very small system, this technique may be an effective and low-cost means of identifying problem areas in the system which require further investigation.



Inside a new manhole, the Invert is the inside bottom of the pipe. The Invert is used to determine the depth which is used to determine the Rise or Slope of the pipe.

The formula for figuring the slope is: rise divided by run.

Flow Capacity

Most sewers are designed with the capacity to flow half full for less than 15 inches in diameter; larger sewers are designed to flow at three-fourths flow. The velocity is based on calculated peak flow, which is commonly considered to be twice the average daily flow. Accepted standards dictate that the minimum design velocity should not be less than 0.60 m/sec (2 fps) or generally greater than 3.5 m/sec (10 fps) at peak flow. A velocity in excess of 3.5 m/sec (10 fps) can be tolerated with proper consideration of pipe material, abrasive characteristics of the wastewater, turbulence, and thrust at changes of direction. The minimum velocity is necessary to prevent the deposition of solids.



Examples of various sewer flow measuring devices.

The Use of a Dye at the Manhole to Determine the Velocity is Done as Follows:

1. Insert dye upstream and begin timing until the dye is first seen at the downstream manhole (t_1); and
2. Total the travel time, and the insertion time from the time the dye is no longer seen at the downstream manhole (t_2).

Once this is complete, add ($t_1 + t_2$) then divide it by 2. This will give you the total average time for the dye. In order to calculate the velocity the travel time is divided by the distance between manholes (note that the time needs to be converted to seconds):

$$\text{Velocity, ft/sec} = \frac{\text{Distance, ft}}{\text{Average time, sec}}$$

There are devices available to measure flow measurements; they all are based on the principle of the cross-sectional area of the flow in a sewer line. This is done by using the table below. Once this has been determined, then the following equations can be used:

Q, cubic feet of flow = Area, sq ft multiplied by Velocity, ft/sec

d/D	Factor	d/D	Factor	d/D	Factor	d/D	Factor
0.01	0.0013	0.16	0.0811	0.31	0.2074	0.46	0.3527
0.02	0.0037	0.17	0.0885	0.32	0.2167	0.47	0.3627
0.03	0.0069	0.18	0.0961	0.33	0.2260	0.48	0.3727
0.04	0.0105	0.19	0.1039	0.34	0.2355	0.49	0.3827
0.05	0.0174	0.20	0.1118	0.35	0.2350	0.50	0.3927
0.06	0.0192	0.21	0.1199	0.36	0.2545	0.51	0.4027
0.07	0.0242	0.22	0.1281	0.37	0.2642	0.52	0.4127
0.08	0.0294	0.23	0.1365	0.38	0.2739	0.53	0.4227
0.09	0.0350	0.24	0.1449	0.39	0.2836	0.54	0.4327
0.10	0.0409	0.25	0.1535	0.40	0.2934	0.55	0.4426
0.11	0.0470	0.26	0.1623	0.41	0.3032	0.56	0.4526
0.12	0.0534	0.27	0.1711	0.42	0.3130	0.57	0.4625
0.13	0.0600	0.28	0.1800	0.43	0.3229	0.58	0.4724
0.14	0.0668	0.29	0.1890	0.44	0.3328	0.59	0.4822
0.15	0.0739	0.30	0.1982	0.45	0.3428	0.60	0.4920

This table works as follows:

To determine the cross-sectional flow for a 12 inch sewer main with a flow depth of 5 inches you would first:

d or depth 5 inches divided by **D** or diameter 12 inches equals 0.42 **d/D**. using the table above find the correct factor for 0.42 d/D.

The factor equals 0.3130, now calculate the cross-sectional area using the following formula:

$$\begin{aligned} \text{Pipe Cross-sectional Area, sq ft} &= \frac{(\text{Factor})(\text{Diameter, in})^2}{144 \text{ sq in/sq ft}} \\ &= \frac{(0.3130)(12 \text{ in})^2}{144 \text{ sq in/sq ft}} \\ &= 0.0313 \text{ sq ft} \end{aligned}$$

Once the Velocity and the cross-sectional area have been determined, the calculation for flow rate is used. This formula is as followed:

$$Q, \text{ cubic feet per second} = (\text{Area, sq ft}) (\text{Velocity, ft/sec})$$

Once this calculation is made, cubic feet can be converted to gallons by multiplying it by 7.48 gal/cubic feet and seconds can be converted to minutes, hours or days by multiplying the gallons with the time.

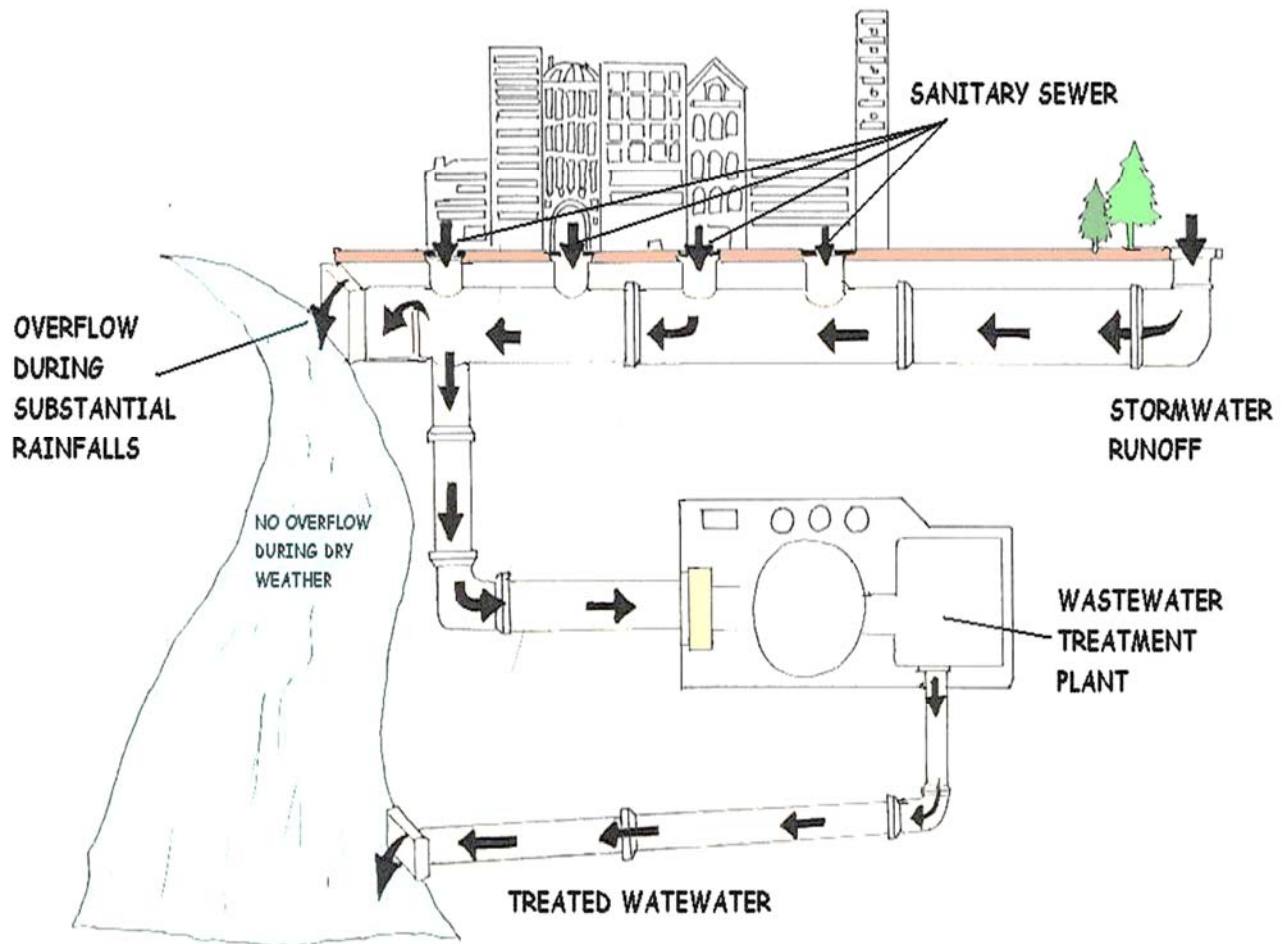

The complexity and expense associated with a utility's CMOM or MOM programs is specific to the size and complexity of the Publicly Owned Treatment Works (POTW) and related infrastructure. Factors such as population growth rate and soil/groundwater conditions also dictate the level of investment which should be made.

Sewer Cleaning

The purpose of sewer cleaning is to remove accumulated material from the sewer. Cleaning helps to prevent blockages and is also used to prepare the sewer for inspections. Stoppages in gravity sewers are usually caused by a structural defect, poor design, poor construction, an accumulation of material in the pipe (especially grease), or root intrusion. Protruding traps (lateral sewer connections incorrectly installed so that they protrude into the main sewer) may catch debris, which then causes a further buildup of solids that eventually block the sewer.

Results of Various Flow Velocities

Velocity Result

- 2.0 ft/sec.....Very little material buildup in pipe.
- 1.4-2.0 ft/sec.....Heavier grit (sand and gravel) begin to accumulate.
- 1.0-1.4 ft/sec.....Inorganic grit and solids accumulate.
- Below 1.0 ft/sec.....Significant amounts of organic and inorganic solids accumulate.
- 1.0 to 1.4 feet per second, grit and solids can accumulate leading to a potential blockage.

Sewer Cleaning Methods

There are three major methods of sewer cleaning: hydraulic, mechanical, and chemical.

Hydraulic cleaning (also referred to as flushing) refers to any application of water to clean the pipe. Mechanical cleaning uses physical devices to scrape, cut, or pull material from the sewer.

Chemical cleaning can facilitate the control of odors, grease buildup, root growth, corrosion, and insect and rodent infestation.

Sewer Cleaning Records

The backbone of an effective sewer cleaning program is accurate recordkeeping. Accurate recordkeeping provides the collection system owner or operator with information on the areas

- Date, time, and location of stoppage or routine cleaning activity
- Method of cleaning used
- Identity of cleaning crew
- Cause of stoppage
- Further actions necessary and/or initiated
- Weather conditions

The owner or operator should be able to identify problem collection system areas, preferably on a map. Potential problem areas identified should include those due to grease or industrial discharges, hydraulic bottlenecks in the collection system, areas of poor design (e.g., insufficiently sloped sewers), areas prone to root intrusion, sags, and displacements. The connection between problem areas in the collection system and the preventive maintenance cleaning schedule should be clear.

The owner or operator should also be able to identify the number of stoppages experienced per mile of sewer pipe. If the system is experiencing a steady increase in stoppages, the reviewer should try to determine the cause (i.e., lack of preventive maintenance funding, deterioration of the sewers due to age, an increase in grease producing activities, etc).

Parts and Equipment Inventory

An inventory of spare parts, equipment, and supplies should be maintained by the collection system owner or operator. The inventory should be based on the equipment manufacturer's recommendations, supplemented by historical experience with maintenance and equipment problems. Without such an inventory, the collection system may experience long down times or periods of inefficient operation in the event of a breakdown or malfunction. Files should be maintained on all pieces of equipment and major tools. The owner or operator should have a system to assure that each crew member has adequate and correct tools for the job.

The owner or operator should maintain a yard where equipment, supplies, and spare parts are maintained and personnel are dispatched. Very large systems may maintain more than one yard. In this case, the reviewer should perform a visual survey at the main yard. In small to medium size systems, collection system operations may share the yard with the department of public works, water department, or other municipal agencies. In this case, the reviewer should determine what percentage is being allotted for collection system items. The most important features of the yard are convenience and accessibility.

The reviewer should observe a random sampling of inspection and maintenance crew vehicles for equipment as described above. A review of the equipment and manufacturer's manuals aids will determine what spare parts should be maintained.

The owner or operator should then consider the frequency of usage of the part, how critical the part is, and finally, how difficult the part is to obtain when determining how many of the part to keep in stock. Spare parts should be kept in a clean, well-protected stock room.

Owner or Operator - Point to Note

The owner or operator should have a procedure for determining which spare parts are critical for the proper operation of the collection system. Similar to equipment and tools management, a tracking system should be in place, including Guide for Evaluating CMOM Programs at Sanitary Sewer Collection Systems procedures on logging out materials, and when maintenance personnel must use them.

The owner or operator should be able to produce the spare parts inventory and clearly identify those parts deemed critical. The reviewer should evaluate the inventory and selected items in the stockroom to determine whether the specified numbers of these parts are being maintained.



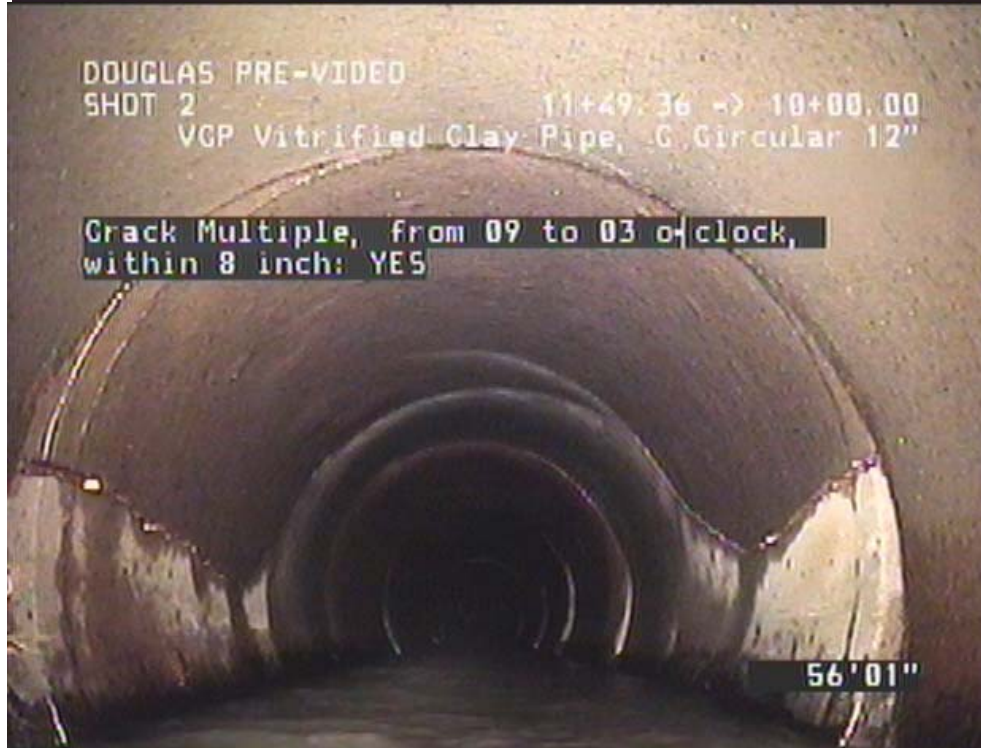

Photographs courtesy of Propipe.

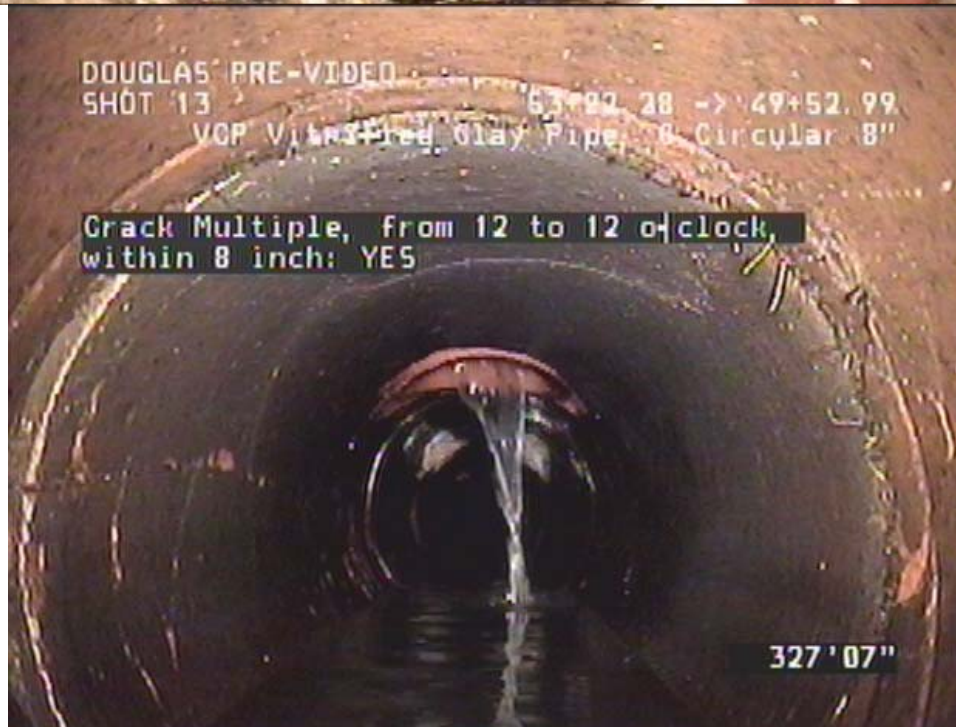
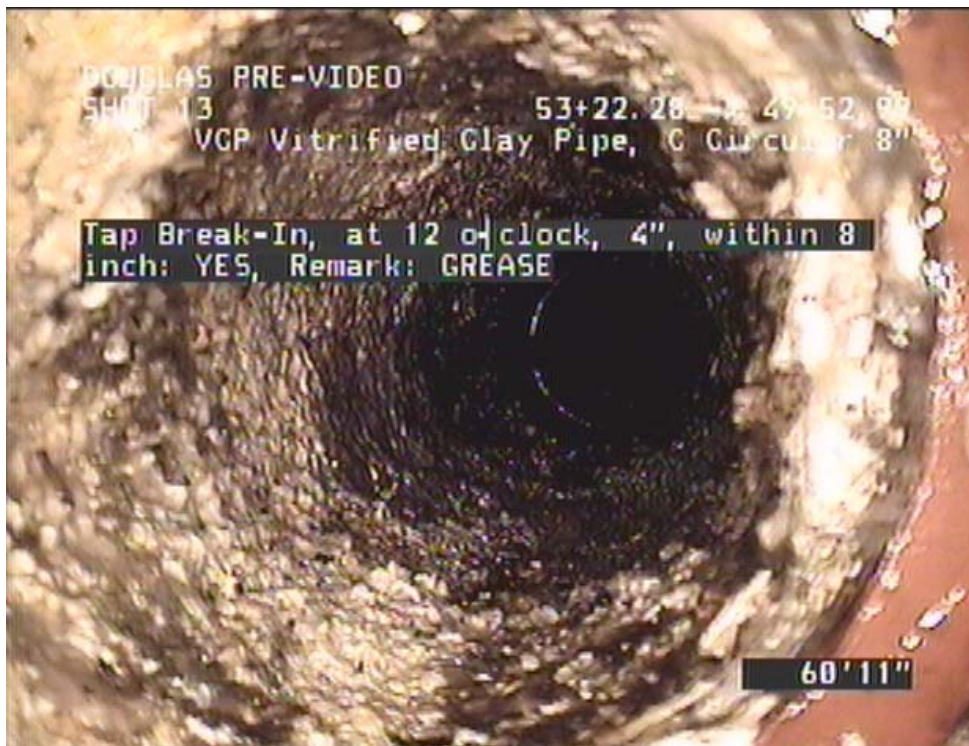

Photographs courtesy of Propipe.

Infiltration and Inflow

What is Infiltration/Inflow (I/I)?

Infiltration occurs when groundwater enters the sewer system through cracks, holes, faulty connections, or other openings. Inflow occurs when surface water such as storm water enters the sewer system through roof downspout connections, holes in manhole covers, illegal plumbing connections, or other defects.

The sanitary sewer collection system and treatment plants have a maximum flow capacity of wastewater that can be handled. I/I, which is essentially clean water, takes up this capacity and can result in sewer overflows into streets and waterways, sewer backups in homes, and unnecessary costs for treatment of this water. It can even lead to unnecessary expansion of the treatment plants to handle the extra capacity. These costs get passed on to the consumer.

I&I (Infiltration and Inflow)

- Infiltration is water (typically groundwater) entering the sewer underground through cracks or openings in joints.
- Inflow is water (typically stormwater or surface runoff) that enters the sewer from grates or unsealed manholes exposed to the surface.



Determining I/I

Flow monitoring and flow modeling provide measurements and data used to determine estimates of I/I. Flow meters are placed at varying locations throughout the sewer collection system to take measurements and identify general I/I source areas. Measurements taken before and after a precipitation event indicate the extent that I/I is increasing total flow. Both infiltration and inflow increase with precipitation. Infiltration increases when groundwater rises from precipitation, and inflow is mainly stormwater and rainwater. Rainfall monitoring is also performed to correlate this data.

Identifying sources of I/I

A Sewer System Evaluation Survey (SSES) involves inspection of the sewer system using several methods to identify sources of I/I:

- Visual inspection - accessible pipes, gutter and plumbing connections, and manholes are visually inspected for faults.
- Smoke testing – smoke is pumped into sewer pipes. Its reappearance aboveground indicates points of I/I. These points can be on public property such as along street cracks or around manholes, or on private property such as along house foundations or in yards where sewer pipes lay underground.
- TV inspection – camera equipment is used to do internal pipe inspections. The City will usually have one 2-3 person crew that can perform TV inspection on over 20 miles of sewer pipe per year.
- Dye testing – Dye is used at suspected I/I sources. The source is confirmed if the dye appears in the sewer system.

Sources of I/I are also sometimes identified when sewer backups or overflows bring attention to that part of the system. The purpose of the SSES is to reduce these incidences by finding sources before they cause a problem.

Repairing I/I Sources

Repair techniques include manhole wall spraying, Insituform pipe relining, manhole frame and lid replacement, and disconnecting illegal plumbing, drains, and roof downspouts.

Efficient Identification of Excessive I/I

The owner or operator should have in place a program for the efficient identification of excessive I/I. The program should look at the wastewater treatment plant, pump stations, permanent meter flows, and rainfall data to characterize peaking factors for the whole system and major drainage basins. The reviewer should evaluate the program, including procedures and records associated with the flow monitoring plan. Temporary meters should be used on a “roving” basis to identify areas with high wet weather flows. Areas with high wet weather flows should then be subject to inspection and rehabilitation activities.



Sewer System Testing

Sewer system testing techniques are often used to identify leaks which allow unwanted infiltration into the sewer system and determine the location of illicit connections and other sources of stormwater inflow.

Two commonly implemented techniques include smoke testing and dyed water testing. Regardless of the program(s) implemented by the owner or operator, the reviewer should evaluate any procedures and records that have been established for these programs. The reviewer should also evaluate any public relations program and assess how the owner or operator communicates with the public during these tests (i.e., when there is a possibility of smoke entering a home or building).

Smoke testing is a relatively inexpensive and quick method of detecting sources of inflow in sewer systems, such as down spouts, or driveway and yard drains, and works best suited for detecting cross connections and point source inflow leaks. Smoke testing is not typically used on a routine basis, but rather when evidence of excessive I/I already exists. With each end of the sewer of interest plugged, smoke is introduced into the test section, Guide for Evaluating CMOM Programs at Sanitary Sewer Collection Systems usually via a manhole. Sources of inflow can then be identified when smoke escapes through them.

Areas Usually Smoke Tested

- Drainage paths
- Ponding areas
- Cellars
- Roof leaders
- Yard and area drains
- Fountain drains

- Faulty service connections
- Abandoned building sewers

If the collection system owner or operator implements a regular program of smoke testing, the program should include a public notification procedure. The owner or operator should also have procedures to define:

- How line segments are isolated.
- The maximum amount of line to be smoked at one time.
- The weather conditions in which smoke testing is conducted (i.e., no rain or snow, little wind and daylight only)

The results of positive smoke tests should be documented with carefully labeled photographs. Building inspections are sometimes conducted as part of a smoke testing program and, in some cases, may be the only way to find illegal connections. If properly connected to the sanitary sewer system, smoke should exit the vent stacks of the surrounding properties. If traces of the smoke or its odor enter the building, it is an indication that gases from the sewer system may also be entering. Building inspections can be labor intensive and require advanced preparation and communication with the public.

Dye Testing

Dyed water testing may be used to establish the connection of a fixture or appurtenance to the sewer. It is often used to confirm smoke testing or to test fixtures that did not smoke. As is the case with smoke testing, it is not used on a routine basis, but rather in areas that have displayed high wet weather flows. Dyed water testing can be used to identify structurally damaged manholes that might create potential I/I problems. This is accomplished by flooding the area close to the suspected manholes with dyed water and checking for entry of dyed water at the frame-chimney area, cone or corbel, and walls of the manhole.

Sewer System Inspection

Visual inspection of manholes and pipelines are the first line of defense in the identification of existing or potential problem areas. Visual inspections should take place on both a scheduled basis and as part of any preventive or corrective maintenance activity. Visual inspections provide additional information concerning the accuracy of system mapping, the presence and degree of I/I problems, and the physical state-of-repair of the system. By observing the manhole directly and the incoming and outgoing lines with a mirror, it is possible to determine structural condition, the presence of roots, condition of joints, depth of debris in the line, and depth of flow.

The reviewer should examine the records of visual inspections to ensure that the following information is recorded:

- Manhole identification number and location.
- Cracks or breaks in the manhole or pipe (inspection sheets and/or logs should record details on defects.)
- Accumulations of grease, debris, or grit
- Wastewater flow characteristics (e.g., flowing freely or backed up.)
- Inflow - Infiltration (presence of clear water in or flowing through the manhole.)

- Presence of corrosion.
- Offsets or misalignments.
- Condition of the frame.
- Evidence of surcharge.
- Atmospheric hazard measurements (especially hydrogen sulfide.)
- If repair is necessary, a notation as to whether a work order has been issued.

Manholes

Manholes should undergo routine inspection typically every one to five years. There should be a baseline for manhole inspections (e.g., once every two years) with problematic manholes being inspected more frequently. The reviewer should conduct visual observation at a small but representative number of manholes for the items listed above.

There are various pipeline inspection techniques, the most common include: lamping, camera inspection, sonar, and CCTV. These will be explained further in the following sections.

Sewer System Inspection Techniques

Sewer inspection is an important component of any maintenance program. There are a number of inspection techniques that may be employed to inspect a sewer system. The reviewer should determine if an inspection program includes frequency and schedule of inspections and procedures to record the results. Sewer system cleaning should always be considered before inspection is performed in order to provide adequate clearance and inspection results. Additionally, a reviewer should evaluate records maintained for inspection activities, including whether information is maintained on standardized logs, and should include:

- Location and identification of line being inspected.
- Pipe size and type.
- Name of personnel performing inspection.
- Distance inspected.
- Cleanliness of the line.
- Condition of the manhole with pipe defects identified by footage from the starting manhole.
- Results of inspection, including estimates of I/I.

Camera Inspection

Lamping involves lowering a still camera into a manhole. The camera is lined up with the centerline of the junction of the manhole frame and sewer. A picture is taken down the pipe with a strobe-like flash. A disadvantage of this technique is that only the first 10-12 feet of the pipe can be inspected upstream and downstream of the access point. Additionally, it has limited use in small diameter sewers. The benefits of this technique include not requiring confined space entry and little equipment and set-up time is required.

Camera inspection is more comprehensive than lamping in that more of the sewer can be viewed. A still camera is mounted on a floatable raft and released into a pipe. The camera takes pictures with a strobe-like flash as it floats through the sewer pipe. This technique is often employed in larger lines where access points are far apart. Similar to lamping, portions of the pipe may still be missed using this technique. Obviously, there also must be flow in the pipe for the raft to float. This technique also does not fully capture the invert of the pipe and its condition. Sonar is a newer technology deployed similarly to CCTV cameras, and described in more detail

below. The sonar emits a pulse which bounces off the walls of the sewer. The time it takes for this pulse to bounce back provides data and an image of the interior of the pipe, including its structural condition. A benefit of this technique is that it can be used in flooded or inaccessible sections of the sewer. The drawback is that the technique requires heavy and expensive equipment.

Sewer scanner and evaluation is an experimental technology where a 360 degree scanner produces a full digital photograph of the interior of the pipe. This technique is similar to sonar in that a more complete image of a pipe can be made than with CCTV, but not all types of sewer defects may be identified as readily (i.e., infiltration, corrosion).

Closed Circuit Television (CCTV) Inspections

Closed Circuit Television (CCTV) inspections are a helpful tool for early detection of potential problems. This technique involves a closed-circuit camera with a light which is self-propelled or pulled down the pipe. As it moves it records the interior of the pipe. CCTV inspections may be done on a routine basis as part of the preventive maintenance program, as well as part of an investigation into the cause of I/I. CCTV, however, eliminates the hazards associated with confined space entry. The output is displayed on a monitor and videotaped. A benefit of CCTV inspection is that a permanent visual record is captured for subsequent reviews.

Sewer System Rehabilitation

The collection system owner or operator should have a sewer rehabilitation program. The objective of sewer rehabilitation is to maintain the overall viability of a collection system. This is done in three ways: (1) ensuring its structural integrity; (2) limiting the loss of conveyance and wastewater treatment capacity due to excessive I/I; and (3) limiting the potential for groundwater contamination by controlling exfiltration from the pipe network.

The rehabilitation program should build on information obtained as a result of all forms of maintenance and observations made as part of the capacity evaluation and asset inventory to assure the continued ability of the system to provide sales and service at the least cost. The reviewer should try to gain a sense of how rehabilitation is prioritized. Priorities may be stated in the written program or may be determined through interviews with system personnel.

There are many rehabilitation methods; the choice of methods depends on pipe size, type, location, dimensional changes, sewer flow, material deposition, surface conditions, severity of I/I, and other physical factors. Non-structural repairs typically involve the sealing of leaking joints in otherwise sound pipe.

Structural repairs involve either the replacement of all or a portion of a sewer line, or the lining of the sewer. These repairs can be carried out by excavating, usually for repairs limited to one or two pipe segments (these are known as point repairs) or by trenchless technologies (in which repair is carried out via existing manholes or a limited number of access excavations).

The rehabilitation program should identify the methods that have been used in the past, their success rating, and methods to be used in the future. A reviewer who wants further guidance on methods of rehabilitation may consult the owner's or operator's policies regarding service lateral rehabilitation, since service laterals can constitute a serious source of I/I.

Manholes should not be neglected in the rehabilitation program. Manhole covers can allow significant inflow to enter the system because they are often located in the path of surface runoff. Manholes themselves can also be a significant source of infiltration from cracks in the barrel of the manhole. The owner or operator should be able to produce documentation on the location and methods used for sewer rehabilitation. The reviewer should compare the rehabilitation accomplished with that recommended by the capacity evaluation program. When examining the collection system rehabilitation program, the reviewer should be able to answer the following questions:

- Is rehabilitation taking place before it becomes emergency maintenance?
- Are recommendations made as a result of the previously described inspections?
- Does the rehabilitation program take into account the age and condition of the sewers?

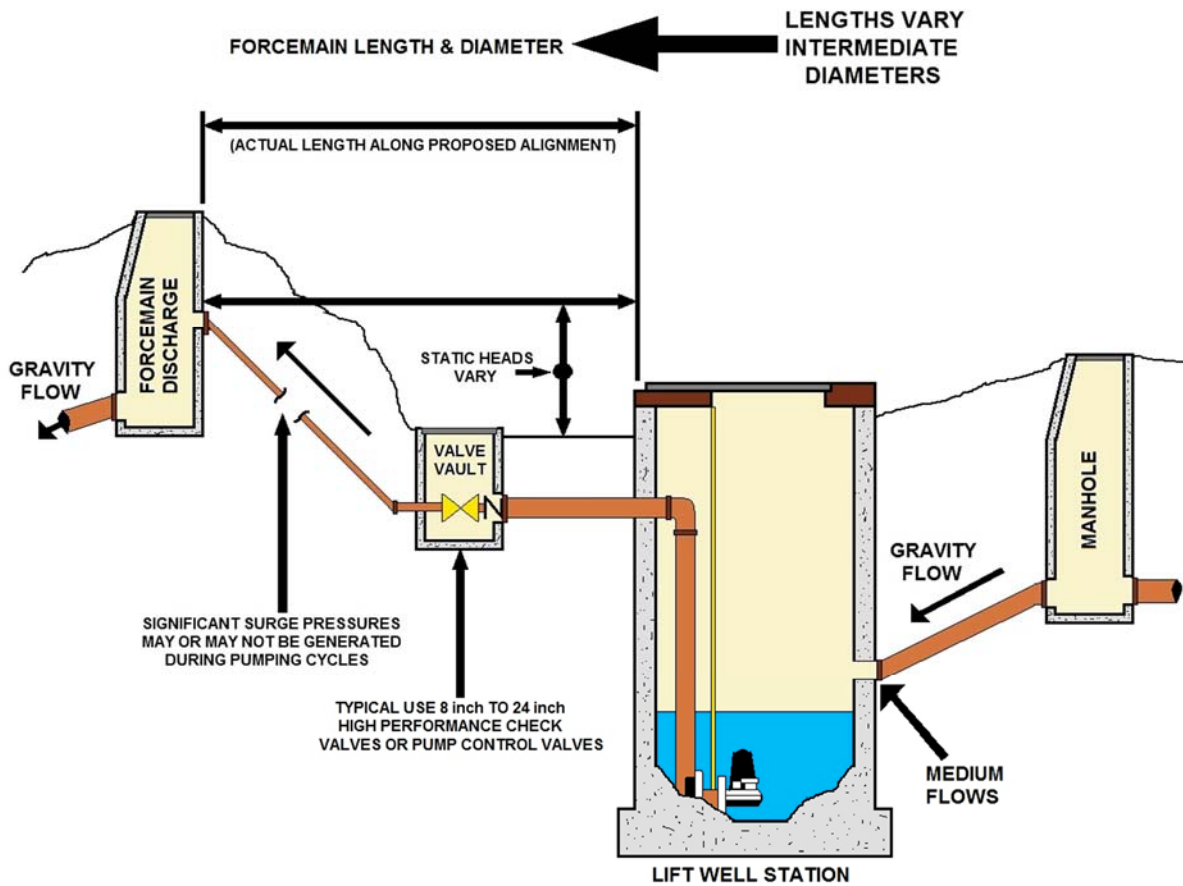

MEDIUM SEWAGE LIFT STATION TYPICAL CHARACTERISTICS

Drains & Vents Chapter 5

Odors in the Plumbing System

The well-designed and correctly installed plumbing system is odorless. Odors are most likely to arise from leaks in the waste or vent piping or from traps which have lost their water seal. In an incorrectly installed system, there are, of course, many opportunities for odors to result from defects in the system, particularly if it is not properly vented.

Unusual odors should never be ignored. Such odors are often an indication that sewer gas is present. Sewer gas, while not always deadly, is noxious and capable of causing headaches and other minor illnesses. Sewer gas is foul smelling air and should be prevented from entering the house.

If it is suspected that sewer gas is entering through a leak in the piping, a plumber will subject the system to a test either by means of smoke, water or oil of peppermint. The test will indicate the location of the leak.

In order to explain how the sewer gas may enter a house through a plumbing fixture, it is necessary to clarify the function of traps and vents. Every plumbing fixture is the terminus of the city water supply system and the beginning of the city sewerage system. The faucets control the water supply. The traps and vents control the sewer air. They do so by a very simple method.

Sewer air will not penetrate a water barrier. Therefore, a device is employed which keeps several inches of water between the house air and the sewer air. This is the trap, which is plainly visible under such plumbing fixtures as sinks and lavatories. It is built into water closets. In the case of bathtubs and shower cabinets, it is usually concealed in the floor or basement.

A trap, however, would lose its water seal by siphonic action every time a fixture is used unless the air on the sewer side is balanced with the air on the house side. This is the function of the vents. Occasionally, due to changes in atmospheric conditions, a compactly vented trap will lose its seal.

Usually, however, when a trap loses its seal it is due either to incorrect design of the vents, absence of vents or to evaporation of the water in the trap. Traps under fixtures that are used infrequently should be filled with water from time to time to insure an adequate trap seal.

Drains

Plumbers get more calls to open clogged drains than for any other service. Many such calls could be prevented by greater care in the use of drains. The most-used drain is the one in the kitchen sink and that is the drain most often clogged.

Preventing this situation can be done by carefully watching what is emptied into the sink drain and by the regular use of a safe biodegradable waste digester. Your plumber can give you more information on these products.

Sink Stoppages

Sink stoppages are usually caused by liquid fats, emulsified by warm dishwater and carried through the pipes. The water cools as it proceeds to the main sewer and leaves the fatty deposits along the way. A film of grease forms on the pipe wall, then another and another. Coffee grounds and bits of food add to this accumulation layer until the pipe becomes impassible.

Pour excess grease into a tin can and throw it out with the garbage, not down the sink drain. When using a food disposer, always let sufficient cold water run to carry the particles down and into the main line to prevent buildup in the smaller waste lines.

In the event of a stoppage, you should have a "plumber's friend," or plunger - a large rubber suction cup with a wooden handle. Cup it tightly over the drain and plunge it vigorously several times. If it is a double drain sink, make sure you seal the other drain, so water will not splash out into the other bowl or on you. Drain piping can also be cleaned by removing the J-bend on the trap below the fixture. First place adhesive tape around the packing nut or wrap the wrench jaws with cloth to prevent scratching the metal surface. If plastic piping is in place, do not grip the nuts too tightly with the wrench, as they can crack easily.

Place a bucket directly under the pipe to catch any dripping from the open pipe. Pull out the clogging material with a piece of wire or small hand-turned cable. If you take the trap off, have some new gaskets ready to slip into the joints.

Using A Sewer Snake

Another handy tool is a sewer "**snake**" or auger. It's basically a flexible metal rod with a spiral hook or ball on the end.



There are two basic snakes: 1) a closet auger with bent tip made to fit in a toilet's built in trap, 2) a drain auger which is a coiled rod or flattened metal strip.

With both augers, when the rod meets an obstruction in the line, tighten the handle and ram the snake into the clog -- sometimes that's all it takes to clear the line. Otherwise, crank the rod clockwise so the hook (or ball) snags the clog.

Back the snake off slightly, then steadily push inward again while turning the handle clockwise until the debris is solidly hooked.

Firmly push the snake back and forth until the obstruction is freed. The clog may have moved a bit further down the line just to get stuck again.

So, repeat the procedure while running water and feeding out more line -- all the way to the septic tank or city sewer line connection if possible.

Once the clog is gone, reconnect the sink's trap and flush the line with water. Check the connections for leaks. Run more water down the drain and monitor it a few minutes to ensure the clog is gone. If the blockage still remains (like tree roots), you may need to rent a commercial "power" auger with a rotor or blade bit that chops up whatever is in the line.

Toilets

A clogged trap way in a water closet is a ticklish problem, so be careful with whatever method you use for cleaning the drain. Most water closets are made of vitreous china which might crack if exposed to extremely hot water.

A plunger will normally handle simple toilet clogs. Another method of cleaning a water closet trap or toilet is the use of an auger with an adjustable, crank-type handle. Known to plumbers as a "**snake**," the spring-steel coil is easily worked past the trap and down the pipe. A three foot auger is inexpensive and will quickly drill through most clogs. Use the auger carefully. Careless handling may crack the toilet.

Tubs

When trying to clear a plugged bathtub drain, place a heavy cloth in the bottom of the bathtub so your shoe soles won't scratch the bath's enameled surface. Hold your hand or rag over the waste and overflow plate, cup the plunger over the drain and plunge it vigorously several times. If it doesn't open easily, the drain may require cabling to open it.

Heavy steel spring coils should not be used to clean traps under lavatories, sinks, or bathtubs. A more flexible type of wire or spring should be used -- one which is easy to work through the bend of the trap.

Floor Drains

To clean out a floor drain, remove the strainer or grating which covers the drain box. The dirt and grease can then be dug out with a spoon or a stick. After that, a hooked wire or coil spring-steel auger will clean out the bend or trap. Check to find out whether a removable clean-out plug has been provided to make this job easier.

Sewer Gases

When the clogging material has been removed from the trap, pour a pail or two of hot water into the drain to wash out any loose material. Check the strainer itself and clean it in hot water and soap in order to open all holes. The floor drain should be checked regularly, especially one that is not often used, since water in the trap may evaporate. This would allow sewer gases to enter the room. Pour a pail of water into the drain periodically in order to make certain of a proper water seal.

Unclogging Sinks

Hair can often clog a bathroom sink and potato peels and other food waste will plug up kitchen sinks. Regardless of the obstruction, unclogging both sinks is done the same way.

Place a plunger over the clogged drain. Add enough water to cover the plunger lip and form a seal.

Plunge straight up and down several times and "pop" the plunger away. Repeat this method a few times to free the clog.

If the clog remains, position a bucket underneath the sink's trap. Unscrew each end of the trap and drain the water into the bucket.

Clean out any debris in the trap and if a kitchen sink has a disposer, disconnect and drain its waste line and clean out any debris.

If no significant debris is found in the sink lines, the clog is located in the sink's drain line or main waste line.

A clog in the main line will also plug other drains above it, and that needs to be cleared with a sewer snake.

Unclogging A Toilet

Use a "fluted" or funnel plunger designed to seal inside a toilet bowl. Extend the fluted flap of the plunger; fit it tightly inside bowl drain to form a good seal.

Plunge up and down several times; to quickly break the seal. Repeat this a few times to work the clog back and forth and eventually free it.

If the clog remains, insert a closet auger into the bowl. Position the bent end of the auger into the bowl's trap and fish the rod through until it hits the clog.

Crank the auger's handle clockwise and push it into the clog a bit more. Once the clog is "hooked" with the spiral tip (or ball) pull the auger back and forth. Repeat these steps until the clog is freed.

Avoid flushing the toilet. It may still be clogged and backup. Instead, fill the bowl with a bucket. If the water level doesn't go down, the clog is still in the line.

Drain-Waste-Vent (DWV) System

The drain-waste-vent system transports all the used water and waste from the house to the septic/sewer system. It's a network of drain pipes that runs to all the sinks, toilets, baths, showers, and washer.

Most new waste systems use rigid plastic PVC (polyvinyl chloride) or ABS (acrylonitrile butadiene styrene) pipe that are sealed with glue. Older homes generally have had cast iron pipe sealed with lead solder. However, today's homes may utilize cast iron pipe sealed with neoprene in some places as a way to avoid the noise plastic creates when water is draining through it.

The soil stack is the main component of the waste drain. It's a vertical "stack" of pipes that starts in the basement/crawlspace floor or wall where it's connected to the outbound sewer/septic line.

The top end of the stack acts as a vent. It extends vertically out through the roof, allowing gases to escape outside and also helps promote drain flow by drawing air inward.

A plugged vent can trap dangerous gases and inhibits drainage; similar to plugging a drinking straw with your thumb to hold liquid.

Make sure the vent doesn't terminate in the attic. Trapped sewer gases can be dangerous, stink and cause serious structural problems. And a system without a vent may actually suck water out a sink's trap, or do the reverse and fill the sink with water when another fixture drains. A trap blocks sewer/septic gases. Without one, sewer gases can flow up the stack, drain pipes and come out wherever there's a drain.

A trap looks like a "U" and is installed below the drain. When water drains, the trap's shape causes a small amount of water to remain in the bend. That water blocks any gases from moving up the pipe and entering the room.

NOTE: Traps are needed on all drains. That is, sinks, tubs, showers, washers, and floor drains all need to have a trap in their drain lines. In most cases, a toilet has a built-in trap and doesn't require a trap in the drain line.

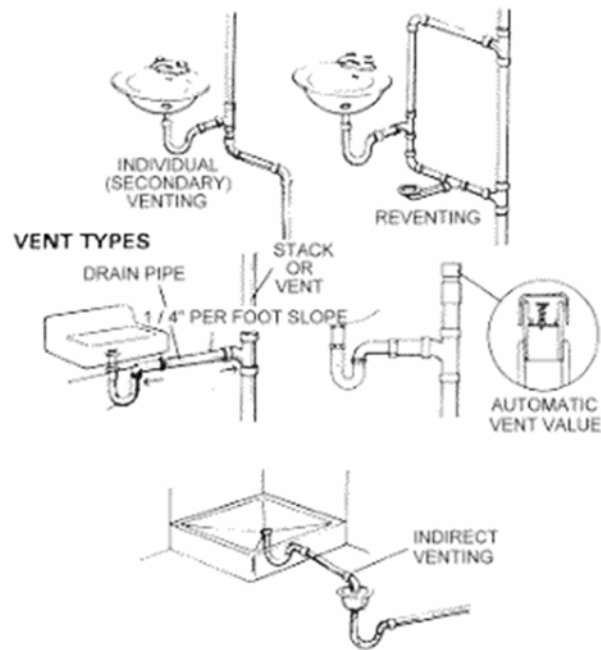



No Hub compression type fitting used on drain, waste and vent lines.

Drain Waste Vent System Installation

Most Common Mistakes

1. Violating or ignoring code restrictions,
2. Not installing D/W/V with at least a 1/4" slope per one foot pipe,
3. Not properly venting or trapping all fixtures,
4. Attaching too many fixtures to a drain or vent pipe,
5. Using pipes that are too small,
6. Not providing enough cleanouts or not providing cleanouts at the prescribed places,
7. Venting the fixture too far from the fixture's trap,
8. Not properly aligning tubing into fittings or stop valves. (Forcing the nut onto the compression ring at an angle when the tubing is at an angle will cause a leak.)
9. Using a fitting in a wrong position,
10. Installing rough plumbing in the wrong location,
11. Reducing pipe size as the pipes run downstream,
12. Cutting pipe too long and not allowing for the ridge in the fittings, and
13. Forcing the trap and waste arm fittings out of alignment and putting too much stress on the nuts and washers in the tubing.
14. Make certain the compression tubing is put in the fittings so that it is evenly tightened.

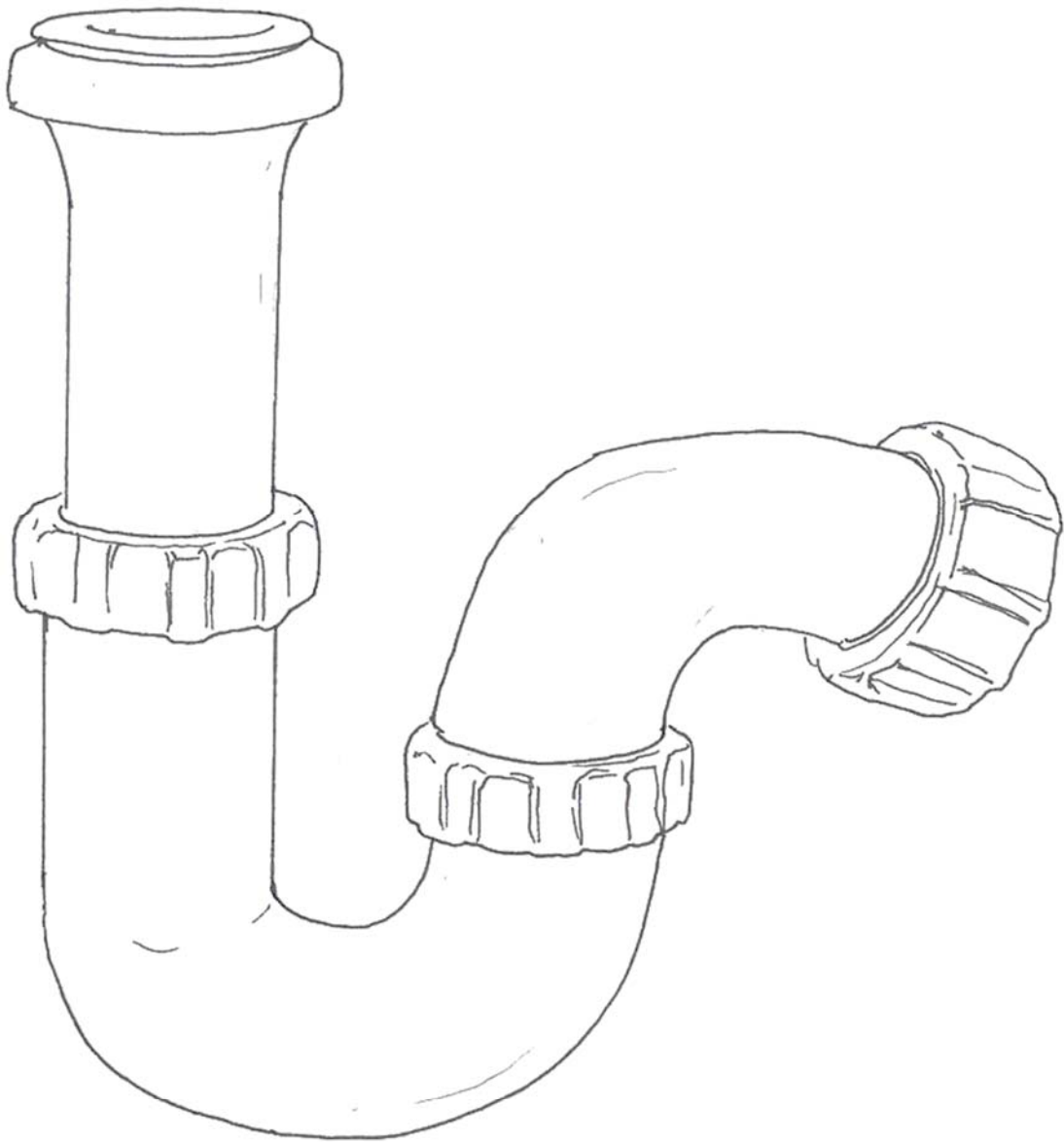

3/4 S-TRAP

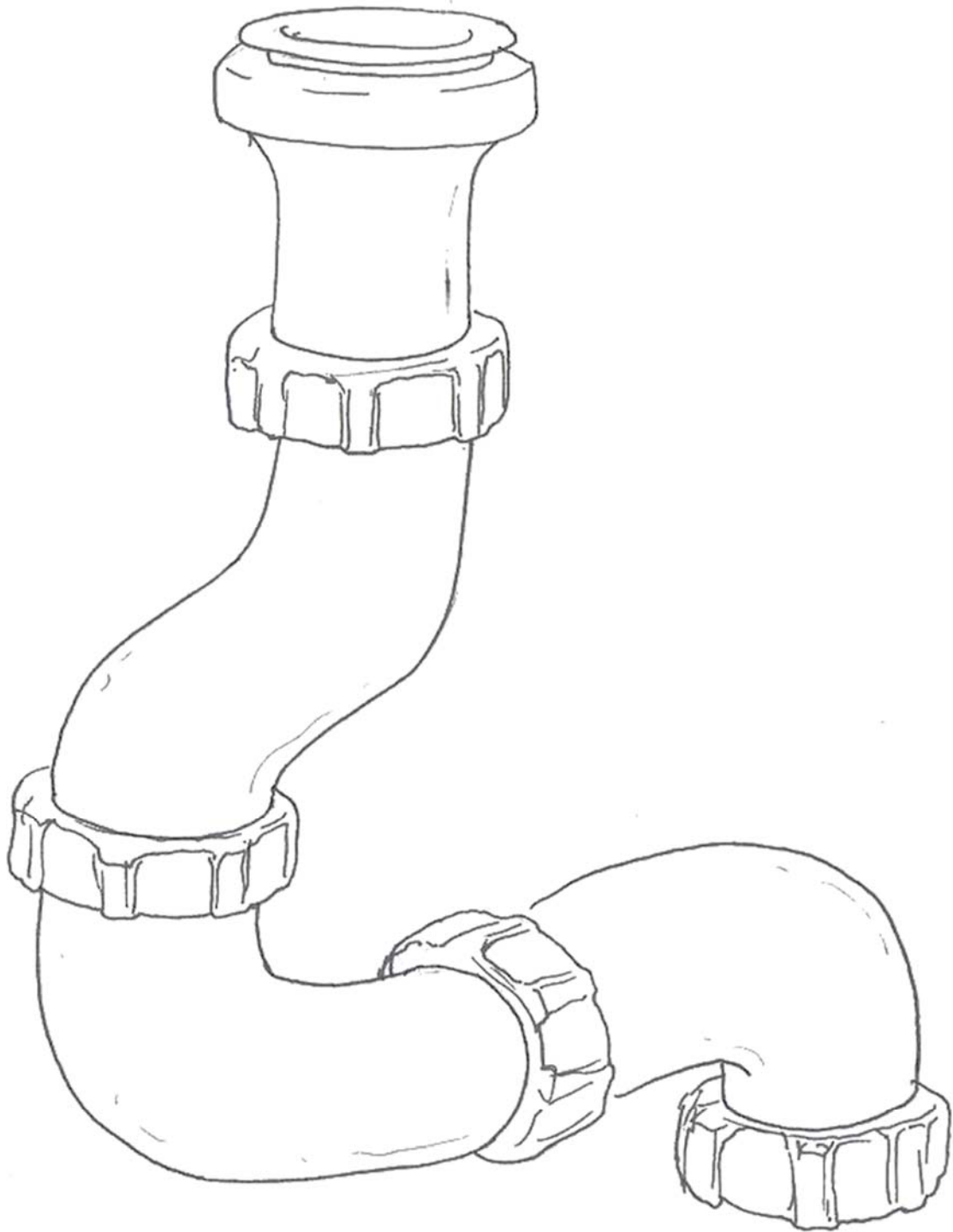

BAG TRAP

Plumbing 101 9/1/2016©TLC (866) 557-1746 Fax (928) 272-0747

Prohibited Joints and Connections in Drainage Systems

Drainage System. Any fitting or connection which has an enlargement, chamber, or recess with a ledge, shoulder, or reduction of pipe area that offers an obstruction to flow through the drain is prohibited. No fitting or connection that obstructs flow shall be used. In existing buildings only a flow control valve or device may be connected to the fixture drain and shall not be considered as an obstruction. The enlargement of a three (3) inch closet bend or stub to four (4) inches shall not be considered an obstruction.

Increasesers and Reducers

Different Sizes. Where different sizes of pipes or pipes and fittings are to be connected, the approved proper size increasers, reducers or reducing fittings shall be used between the two sizes.

General Requirements - Material and Design

- a) **Quality of Fixtures:** Plumbing fixtures shall comply with approved designs, be constructed from approved materials, have smooth, impervious surfaces and be free of defects and concealed fouling surfaces.
- b) **Used plumbing material, equipment and fixtures for plumbing installations shall comply with this Part.**
- c) **Any plumbing equipment condemned by the Department because of wear, damage, defects or sanitary hazards shall not be used in a plumbing system.**

Overflows

- a) **Design.** When any fixture is provided with an overflow, the waste piping shall be so designed that the standing water in the fixtures cannot rise in the overflow when the stopper is closed or remain in the overflow when the fixture is emptied.
- b) **Connection.** The overflow pipe from a fixture shall be connected on the house or inlet side of the fixture trap, except that overflows of flush tanks may discharge into the water closets or urinals served by them. No overflow shall be connected to any other part of the drainage system.

Installation

- a) **Cleaning.** Plumbing fixtures shall be installed in a manner to afford easy access for cleaning.
- b) **Securing Fixtures.** Floor outlet or wall hung fixtures shall be secured by screws or bolts of copper, brass, or other equally durable corrosion resistant materials.
- c) **Wall-Hung Fixtures .** Wall-hung fixtures shall be rigidly supported by a concealed metal supporting member so that no strain is transmitted to the fixture connection.
- d) **Setting.** Plumbing fixtures and traps shall be set level and in a true alignment.
- e) **Water Supply Connection.** Hot and cold, tempered and cold, or tempered water only shall be supplied to all plumbing fixtures that are designed for hot and cold, tempered

and cold, or tempered water. All mixing faucets and single lever faucets shall have both hot or tempered and cold water connected to them with the hot or tempered water supply on the left side of the faucet. The cross piping of hot or tempered and cold water to a mixing faucet by internal modification of the faucet shall not be allowed. Each lavatory and sink faucet shall have supply pipes which are accessible.

f) **Improper Location.** Piping, fixtures, or equipment shall not be located or installed in such a manner as to interfere with the normal operation of windows, doors, or other exit openings. Plumbing fixtures shall be installed in an area where there is sufficient room for the fixture to be used for its intended purpose.

g) Where plumbing is installed it shall meet the requirements of the plumbing authority.

h) **Surrounding Materials.** Where water closets or urinals are installed for public use, the flooring under the fixture base extending to at least 18 inches from the front and both sides of the water closet or urinal, and extending from the back of the water closet or urinal to the wall, shall be of non-absorbent material.

i) A hot water heater thermostat shall not be an acceptable alternative water temperature control device.

Prohibited Fixtures

a) Drinking fountains shall not be installed in public toilet rooms.

b) Fixed wooden, concrete, cement or tile wash trays or sinks used for food preparation, utensil washing or hand washing shall not be installed in any food service establishment or commercial food establishment.

c) Bathtub liners/inserts are prohibited unless all of the following conditions are met:

1) Bathtub liners/inserts must be manufactured to an exact fit over existing bathtubs or be custom fabricated according to the dimensions of an existing bathtub;

2) The floor (bottom surface) of the liner/insert must have a slip resistant surface; and

3) The bathtub liner/insert must be manufactured/fabricated from high-impact plexiglass/ABS or acrylic/plastic material.

Indirect Waste Piping

- a) **Food and Beverage Handling.** Commercial dishwashing machines, dishwashing sinks, pot washing sinks, pre-rinse sinks, silverware sinks, bar sinks, soda fountain sinks, vegetable sinks, potato peelers, ice machines, steam tables, steam cookers and other similar fixtures shall have their drain lines indirectly discharged to a proper receptor. The only exception shall be when such fixtures are located adjacent to a floor drain. The waste may be directly connected on the sewer side of the floor drain trap provided the fixture waste is trapped and vented as required by this Part, and the floor drain is located within 4 feet horizontally of the fixtures and in the same room. In the case of direct connection, no other fixture waste shall be connected between the floor drain trap and the fixture protected. All indirect waste shall discharge to a vented trap located as close as possible to the fixture and in the same room.
- b) **Connection.** Indirect waste connections shall be provided for drains, overflows, and relief valves from the water supply system. A clear water waste shall discharge through an indirect waste into a sanitary or storm drain system located on the same floor.
- c) **Sterile Materials.** Stills, sterilizers and other appliances, fixtures, devices and water and waste connections used for preparation of sterile material shall be indirectly discharged to the drainage system.
- d) **Swimming Pools.** When backwash or other waste water from a swimming pool filter discharges to the sanitary waste system it shall be indirectly wasted. When deck drains around a pool discharge to the sanitary waste system they shall be indirectly wasted.
- e) **Clear Water Wastes.** Water lifts, expansion tanks, cooling jackets, sprinkler systems, drip or overflow pans, or similar devices which discharge clear water only shall discharge indirectly into a building storm drain, building drain or building sewer, located on the same floor.
- f) **Fire Sprinkler Systems.** The relief valve (port) of a backflow device located on a fire sprinkler system which contains an additive shall drain indirectly to the building drain.
- g) **Cleaning.** Indirect waste piping shall be so installed as to permit access for flushing and cleaning.

Material and Size

Indirect waste pipe sizes shall be the same as the fixture outlets, but at least three-fourths (3/4) inch.

Length and Grade

- a) **Maximum Length.** The maximum developed length of the indirect waste of any sanitary waste line shall not exceed 5 feet.
- b) **Grade.** Indirect waste pipes shall be installed at a uniform grade.

Air Gaps

The air gap between an indirect waste and the drainage system shall be at least two (2) times the diameter of the fixture drain or drainage pipe served, but shall never be less than one (1) inch.

Stack Vents, Vent Stacks, Main Vents

- a) Design. A properly designed and installed venting system, in conjunction with the soil or waste system is essential to protect trap seals and prevent siphonage, aspiration, or back pressure. The venting system shall be designed and installed to permit the admission or emission of air so that under normal and intended use the seal of any fixture trap shall never be subjected to a pneumatic pressure differential of more than a one (1) inch water column. If a trap seal is subject to loss by evaporation, means shall be provided to prevent loss of the trap seal.
- b) Installation. A stack vent, vent stack or a main vent shall be installed with a soil or waste stack whenever back vents, relief vents, or other branch vents are required.
- c) Terminal. Vents shall terminate independently above the roof to the outside atmosphere, or shall be connected to another vent at least six (6) inches above the flood-level rim of the highest fixture.
- d) Main Stack. Each building in which plumbing is installed shall have at least one main vent stack no smaller than three (3) inches for each building drain installed.

Vent Terminals

- a) Roof Extensions. Extensions of vent pipes through a roof shall be terminated at least 12 inches above such roof unless a roof is to be used for any purpose other than weather protection. If a roof is to be used for any purpose other than weather protection, the vent shall be extended at least seven (7) feet above the roof.
- b) Flashings. Each vent terminal shall be made water-tight with the roof by proper flashing.
- c) Location of Vent Terminal. No vent terminal from a drainage system shall be directly beneath a door, window, overhang or other ventilating intake opening of the building, nor shall any such vent terminals be within 12 feet horizontally of such an opening unless it is at least two (2) feet above the top of such opening.
- d) Extensions Outside Building. No soil, waste or vent pipe extension (except for vent terminals as provided in (a) and (c) above) shall be located on the outside of a wall of any building, but shall be installed inside the building. Vents located within an exterior wall or in a wall adjacent to an unheated space shall be protected from freezing.
- e) Flag poles. Vent terminals shall not be used for the purpose of supporting flag poles, television aerials, or similar purposes.

Water Distribution System Chapter 6

Water Supply System

A house's water supply may come from a private well or a service pipe that connects to a city water main. In most cases, either water source is located in the basement/crawlspace.

A house with a private well utilizes a pump to push water up into a pressure tank where it is stored for use. When the tank empties, the pump is reactivated to fill the tank,

A house with city water has a "live" water supply line that's connected to a water main and a water meter. The meter is usually the dividing point between the city-owned lines and the homeowner's lines.

Both systems usually have a 1/2" or larger copper pipe that enters through the basement floor or wall. The line has a shut-off valve located near the beginning of the incoming line so the water supply can be stopped in case of repairs or an emergency.

Water supply lines are made of copper, CPVC (chlorinated polyvinyl chloride) plastic, or in older homes possibly galvanized steel. Cold water lines branch out from the main pipe, while hot water lines originate from the hot water heater.

System design depends on the area that you live. You may be a flatlander, like in Texas, and the services could be spread out for miles. You may live in the Rocky Mountain area and have many fluctuating elevations. Some areas may only serve residents on a part-time basis and water will sit for long periods of time, while other areas may have a combination of peaks and valleys with short and long distances of service. Before you design the system you need to ask yourself some basic questions.

1. ***What is the source of water?***
2. ***What is the population?***
3. ***What kind of storage will I need for high demand and emergencies?***
4. ***How will the pressure be maintained?***

System Elements

The elements of a water distribution system include distribution mains, arterial mains, storage reservoirs, and system accessories. These elements and accessories are described as follows:

- **DISTRIBUTION MAINS** Distribution mains are the pipelines that make up the distribution system. Their function is to carry water from the water source or treatment works to users.
- **ARTERIAL MAINS** Arterial mains are distribution mains of large size. They are interconnected with smaller distribution mains to form a complete gridiron system.
- **STORAGE RESERVOIRS** Storage reservoirs are structures used to store water. They also equalize the supply or pressure in the distribution system. A common example of a storage reservoir is an aboveground water storage tank.

Distribution Valves

The purpose of installing shutoff valves in water mains at various locations within the distribution system is to allow sections of the system to be taken out of service for repairs or maintenance, without significantly curtailing service over large areas.

Valves should be installed at intervals not greater than 5,000 feet in long supply lines, and 1,500 feet in main distribution loops or feeders. All branch mains connecting to feeder mains or feeder loops should have valves installed as close to the feeders as practical. In this way, branch mains can be taken out of service without interrupting the supply to other locations.



In the areas of greatest water demand or when the dependability of the distribution system is particularly important, valve spacing of 500 feet may be appropriate.

At intersections of distribution mains, the number of valves required is normally one less than the number of radiating mains. The valve omitted from the line is usually the one that principally supplies flow to the intersection. Shutoff valves should be installed in standardized locations (that is, the northeast corner of intersections or a certain distance from the center line of streets), so they can be easily found in emergencies. All buried small- and medium-sized valves should be installed in valve boxes. For large shutoff valves (about 30 inches in diameter and larger), it may be necessary to surround the valve operator or entire valve within a vault or manhole to allow repair or replacement.

Classification of Valves

There are two major classifications of water valves: **Rotary and Linear**. Linear is a fancy word for up and down or blade movement.

Gate Valve Linear Valve *Our primary Linear valve*

The most common valve in the distribution system. Primarily used for main line shut downs. Should be exercised on annual basis.

Gate valves are used when a straight-line flow of fluid and minimum flow restriction are needed. Gate valves are so-named because the part that either stops or allows flow through the valve acts somewhat like a gate.

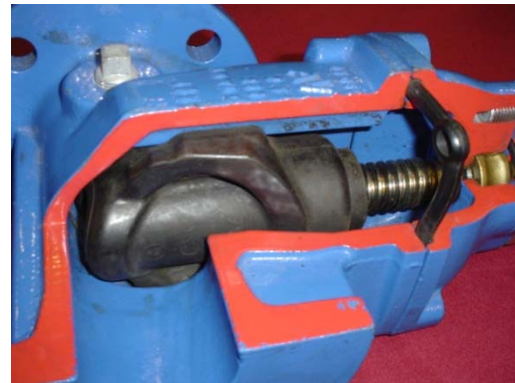

The gate is usually wedge-shaped. When the valve is wide open the gate is fully drawn up into the valve bonnet. This leaves an opening for flow through the valve the same size as the pipe in which the valve is installed.

Valve Glossary

Here are some of the common valves and related information.

Air and Vacuum relief valve: Both of these functions are in one valve. These valves can combine three functions; they can allow large amounts of air to escape during the filling of a pipeline, permits air to enter a pipeline that is being drained and allow entrained air to escape while a line is operating under pressure. Distribution system water quality can be adversely affected by improperly constructed or poorly located blowoffs of vacuum/air relief valves. Air relief valves in the distribution system lines must be placed in locations that cannot be flooded. This is to prevent water contamination. The common customer complaint of Milky Water is sometimes solved by the installation of these air relief valves.

Altitude valve: Are often used on supply lines to elevated tanks or standpipes. These close automatically when the tank is full and open when the pressure on the inlet side is less than that on the tank side of the valve. These valves control the high water level and prevent overflow. Altitude-Control Valve is designed to, 1. Prevent overflows from the storage tank or reservoir, or 2. Maintain a constant water level as long as water pressure in the distribution system is adequate.

Butterfly valve: Has a movable disc as large as the full bore opening of the valve.

Check valve: Are often used on the discharge side of pumps to prevent backflow.

Gate valve: Is a linear valve used to isolate sections of the water main, to permit emergency repairs without interruption of water service to customers.

Pressure sustaining valve: Maintains constant downstream pressure regardless of fluctuating demand. The valve is usually a globe design controlled by a diaphragm with the diaphragm assembly being the only moving part in the valve. Can also be used as an automatic flow-control valve.

Pressure regulating valve: A valve that controls water pressure by restricting flows. The pressure downstream of the valve regulates the amount of flow. Usually these valves are of the globe valve design. **Pressure Regulation Valves** control water pressure and operate by restricting flows. They are used to deliver water from a high pressure to a low-pressure system. The pressure downstream from the valve regulates the amount of flow. Usually, these valves are of the globe design and have a spring-loaded diaphragm that sets the size of the opening.

Pressure relief: The simplest type of surge pressure relief is a pressure relief valve. These valves respond to pressure variations at their inlets.

What screen size and protection should air vacuum release valves have above and below ground?

Vents should be screened to keep out birds and animals that may contaminate the water. A screen with 1/4 mesh openings is required. Some vents have flap valves that will operate to relieve excess pressure or vacuum if the screen becomes blocked.

What types of water contamination problems could result from improper installation of air vacuum and relief valves?

All overflow, blow off, or cleanout pipes should be turned downward to prevent entrance of rain and should have removable #24-mesh screens to prevent the entrance of birds, insects, rodents, and contaminating materials.

The Singing Key

Dr. Rusty recommends that you listen to the Valve Key when shutting down a Gate valve. You will easily hear it sing as you shut the water off or leak by. It is very easy to create a water hammer when opening or closing a Gate valve. Always take your time when operating a Gate valve or any valve. I know that most of you will not listen to me and you will end up breaking plastic water services and customer's water lines at first. Next, you'll move up to water main breaks. We like to blame the Fire Department or Street Sweepers for water hammers, and they should be blamed, but most water hammers are created by water personnel. Yes, I said it. A great example is watching a rookie shut down or open a fire hydrant. These young rookies like to turn the hydrant on or off as fast as possible, like the Firemen do. Pretty soon, the hydrant starts chattering and pumping. The ground feels like an earthquake and the rookie pretends that nothing is happening. We've all done this and if you haven't, you've probably never worked in the field.

Problems

Valve Jammed Open

Dr. Rusty recommends that opened valves should not be jammed-tight on the backseat.

Always back the valve-off a quarter turn from the fully opened position.

Note that motor operated valves coast inevitably to the backseat by tripping on a limit switch. Valves should not be back seated on torque.

Valve Jammed Closed

Variations in the temperature and/or pressure of the working fluid are often the cause of a valve failing to open.

Thermal binding can occur in high temperature situations depending on the seat and wedge material, length of exposure and closing torque applied. Thermal binding can cause galling on the valve sealing surfaces as well as on the guides.

A valve can lock in the closed position when high pressure enters the cavity and has no way to escape. This is known as over-pressurization.

If Excessive Torque is Needed to Work the Valve

Variations in the temperature and/or pressure of the working fluid are often the cause of a valve failing to open.

Thermal binding can occur in high temperature situations depending on the seat and wedge material, length of exposure and closing torque applied. Thermal binding can cause galling on the valve sealing surfaces as well as on the guides. A valve can lock in the closed position when high pressure enters the cavity and has no way to escape. This is known as over-pressurization. We will cover this in a later section.

Single direction sealing gate valves have a nameplate on the side of the valve that has a relief hole or pressure equalizer. This should be the high pressure side when the valve is closed.



Here is a nasty 4 inch broken gate valve with serious Tuberculation. The valve is broken closed. The rust particles are sharp and can easily cut the water service worker. The flange bolts or Tee bolts were cut off to replace this valve. The rubber gasket will leave a black ink like stain on your clothes and in the water line as well. You will see lots of nasty stuff in the top portion of a valve. Some engineers or big shots refer to this area of the valve as the “Angular space”. If they really knew that this space contained nasty particles or debris and sediment they would never visit your Yard or facility again.

One practice that I am not sure about is the common procedure of only removing the bonnet or removing the guts of a closed valve and keeping the valve body on the line. I guess that sometimes this practice is necessary, and I don't like removing the guts and packing of cement and a redwood plug in the stem hole but it happens. Dr. Rusty's advice, when working on wastewater and water valves is difficult practice because of mud, debris and because water lines are under pressure, but be super careful of rust particles cutting your skin. Get in line at the Doctor's or Health Provider's facility and get all of your shots. Especially Tetanus and Hepatitis.



Notice the corrosion inside this cast iron main.

This corrosion is caused by chemical changes produced by electricity or electrolysis. We call this type of corrosion tuberculation. It is a protective crust of corrosion products that have built up over a pit caused by the loss of metal, due to corrosion or electrolysis. This type of corrosion will decrease the C-Factor and the carrying capacity in a pipe. Crenothrix bacteria or Red-Iron bacteria will live in the bioslime in this type of tuberculation. Now for dealing with this nasty bacteria—there are two methods: the fast method, super chlorinate and flush forever. Or, replace the line with a nice plastic water main. It is up to your supervisor, but remember the nasty bacteria and slime in the water. No one that knows about it will ever drink water from the house service. We need to do a better job.



Gate valve storage procedures. Dr. Rusty recommends to always store a gate valve with the gate up or opened. Not like this picture. Sunlight will give the rubbers a good shot of Vitamin D and a sunburn, destroying the rubbers with ultraviolet radiation. I like to keep the valves covered and clean and I want you to do the same. I know that some of you don't care because these valves are so darn heavy and bother-some. We are professionals and must remember the final outcome. We provide drinking water to the public. Notice the two different styles of flange fittings.

Knife Gate Valve

Always follow standard safety procedures when working on a valve. Install the valve so that the arrows on both sides of the body are in the direction of positive pressure differential.

The preferred orientation is with the stem vertical and the handwheel pointing up. The opposite orientation is not recommended, because fiber and dirt can build-up in the bonnet.

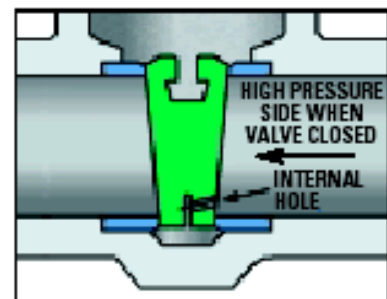

Service connections are used to connect individual buildings or other plumbing systems to the distribution system mains. See the Angle stop.



Water Meter Re-setter, Riser, or sometimes referred to as a copper yoke. There is also a cast iron version which is best broken off with two sledge or cocking hammers when it's time to replace or retrofit the service. You almost always replace a yoke stop hot. A Yoke stop is an Angle Stop most of the time but I've seen a nasty galvanized valve that is also used in this situation.



Common distribution fittings: Single check, Poly Pig, 1 inch repair clamp, 4 inch full circle clamp, T- Bolt and a corp. and saddle. Note from Dr. Rusty, Single checks are not a backflow assembly and will probably stick open over time. I know that most systems will pay for these but unless you replace or test these checks, they will not hold up. Most fitting salesmen will not tell you this little tidbit. Notice the Corp, it is a ball type valve.



Ductile pipe cement-lined iron pipe. I've seen thousands of dollars of pipe that is dropped or moved with the front bucket of a backhoe and destroyed. This destroys the interior protection of the pipe, causing leaks which will start in a few years. I know that some of you welcome this as job security. These nitwits need job security, but water professionals do not need crappy work to keep them employed. Always protect and store all types of pipe covered in a pipe rack. This goes for the proper storage of rubbers as well.



Flex Coupling--sometimes referred to as a Dayton; used to join pipes or to "cut-in a valve." You will learn that you can use different sizes to join pipe or even file out the inside diameter to adjust to larger pipes like ACP. This flex coupling only has three bolts. I like four or more for work with larger pipe work. Dr. Rusty's trick, when working on a water line, I like to turn the valves on slowly to fill the water main as the flex couplings are being tightened. This allows the air to escape and for you to find leaks. It also allows debris in the main to flush out.



Here is a four-way pipe cutting tool used for iron pipe. Be careful not to break the wheels by over-tightening. I personally like 4-Ways because of the nice cut. You will learn to recognize the distinct snap of cut pipe. The only drawback to these cutters is cutting a small section out of the main. You may need to make two or three more cuts and break the section out with a cocking hammer. It will easily cut ductile, galvanized, and even plastic. Plastic pipe cutters utilize sharper cutting wheels. Rookies like to thread the pipe rather than cut the pipe. It is fun to watch and good to tease these rookies about it. Especially if they have just finished jumping a stop with the valve closed or no ball. Good times for sure in the crazy Distribution field.

Photograph on right, difficult to see, these are pipe crimpers. These will easily and effectively stop flow in copper or plastic pipe in tubing less than 2 inches. The only problem is dealing with the crimp when you are finished. I suggest placing a flex coupling over the crimp in plastic and completely cutting the crimped area out when done in copper pipe.





Top photograph, two gate valves blew out, you can see the kickers or thrust blocks in the back ground. Bottom photograph, a tapping machine and a new gate valve. These tapping machines are very, very expensive.





Therefore, there is little pressure drop or flow restriction through the valve. Gate valves are not suitable for throttling purposes. The control of flow is difficult because of the valve's design, and the flow of fluid slapping against a partially open gate can cause extensive damage to the valve. Except as specifically authorized, gate valves should not be used for throttling.

Common Rotary Valves

Globe Valve Rotary Valve

Primarily used for flow regulation, and works similar to a faucet. They are rare to find in most distribution systems, but can be found at treatment plants. Always follow standard safety procedures when working on a valve. Most Globes have compact OS & Y type, bolted bonnet, rising stems, with renewable seat rings. The disc results with most advanced design features provide the ultimate in dependable, economical flow control.

Globe valves should usually be installed with the inlet below the valve seat. For severe throttling service, the valve may be installed so that the flow enters over the top of the seat and goes down through it. Note that in this arrangement, the packings will be constantly pressurized. If the valve is to be installed near throttling service, verify with an outside contractor or a skilled valve technician. Globe valves, per se, are not suitable for throttling service.

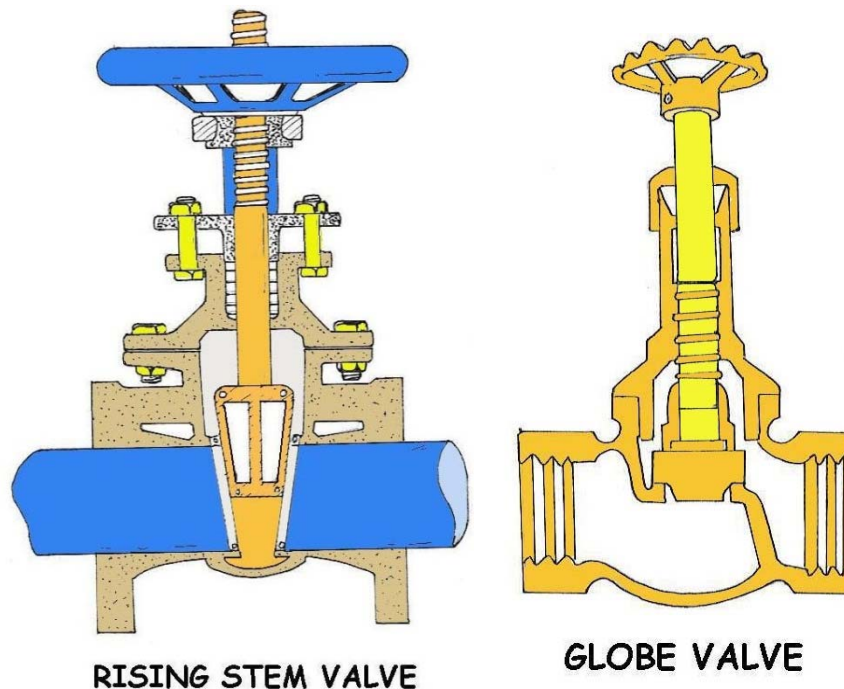

The valve should be welded onto the line with the disc in the fully closed position. Leaving it even partially open can cause distortion and leaking. Allow time for the weld to cool before operating the valve the first time in the pipeline. The preferred orientation of a globe valve is upright. The valve may be installed in other orientations, but any deviation from vertical is a compromise. Installation upside down is not recommended because it can cause dirt to accumulate in the bonnet.

Globe Valve Problems and Solutions

If the valve stem is improperly lubricated or damaged-- Disassemble the valve and inspect the stem. Acceptable deviation from theoretical centerline, created by joining center points of the ends of the stem is $0.005''/\text{ft}$ of stem. Inspect the threads for any visible signs of damage.

Small grooves less than 0.005" can be polished with an Emory cloth. Contact specialized services or an outside contractor if run-out is unacceptable or large grooves are discovered on the surface of the stem.

If the valve packing compression is too tight--Verify the packing bolt torque and adjust if necessary.

Foreign debris is trapped on threads and/or in the packing area--This is a common problem when valves are installed outdoors in sandy areas and areas not cleaned before operating.

Always inspect threads and packing area for particle obstructions; even seemingly small amounts of sand trapped on the drive can completely stop large valves from cycling. The valve may stop abruptly when a cycle is attempted. With the line pressure removed from the valve, disconnect the actuator, gear operator or handwheel and inspect the drive nut, stem, bearings and yoke bushing. Contaminated parts should be cleaned with a lint-free cloth using alcohol, varsol or equivalent. All parts should be re-lubricated before being re-assembled. If the valves are installed outdoors in a sandy area, it may be desirable to cover the valves with jackets.

If the valve components are faulty or damaged--contact specialized services or an outside contractor.

If the valve's handwheel is too small--Increasing the size of the handwheel will reduce the amount of torque required to operate the valve. If a larger handwheel is installed, the person operating the valve must be careful not to over-torque the valve when closing it.



Bellow Seal Valve

Always follow standard safety procedures when working on a valve.

Bellows seal valves provide a complete hermetic seal of the working fluid. They are used in applications where zero leakage of the working fluid into the environment is permitted.

Bellows seal valves are specially modified versions of the standard valves. The installation information that applies to gate and globe valves will apply to bellows seal valves.

A packing leak signifies that the bellows has ruptured or the bellows-assembly weld has a crack. Dr. Rusty does not recommend repairing or reusing a damaged bellows. Instead, Dr. Rusty suggests replacing the entire bonnet assembly including bellows and stem.

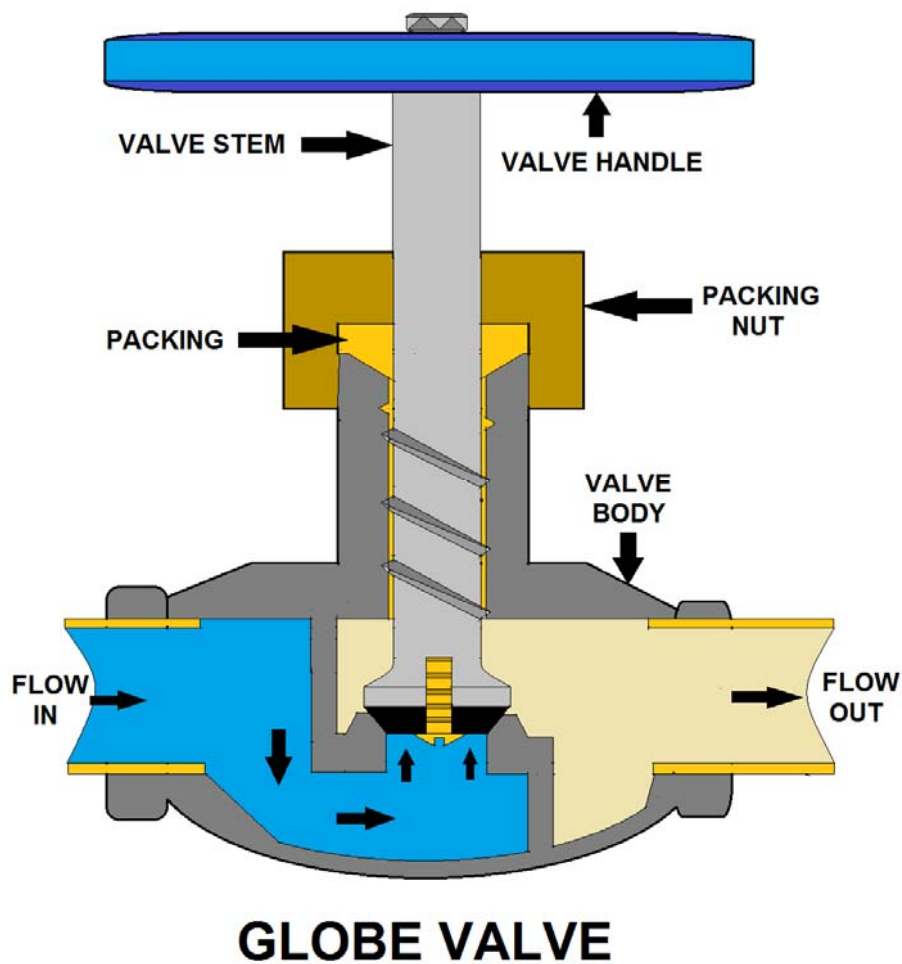

Pressure Sustaining Valve

Pressure sustaining valves are used to sustain the system pressure to a predetermined maximum level. The applications balance the pressure distribution throughout the whole system by maintaining the minimum pressure for high altitude users. Pressure sustaining valves are also used to prevent discharging of the pipe system when any user starts to operate. More in a few more pages.

Pressure Reducing Valve

Pressure reducing valves maintain a predetermined outlet pressure which remains steady and unaffected by either changing of inlet pressure and/or various demands. Pressure Reducing Valves are self-contained control valves which do not require external power. More in a few more pages.

Insertion Valves *Rotary Valve*

You know sometimes you can obtain a shut down and you have two choices. Do it hot or cut in an insertion or inserting valve. An Insertion valve is normally a Gate Valve that is made to be installed on a hot water main. A few years ago, this was a serious feat. First, you had to pour ten yards of mud or cement and come back and cut the valve in. No longer. The Insertion valve machine and tap works like a tapping sleeve. The only difference is that the tap points up and not to the side. I recommend that any major system budget money to purchase this equipment. It will pay for itself on the first job. Otherwise, contract the work out. You can see in the photograph a manually operated tapping machine. I prefer the electric. Note: see the sweet shoring shield set-up. It is rare to see a nice shoring job.

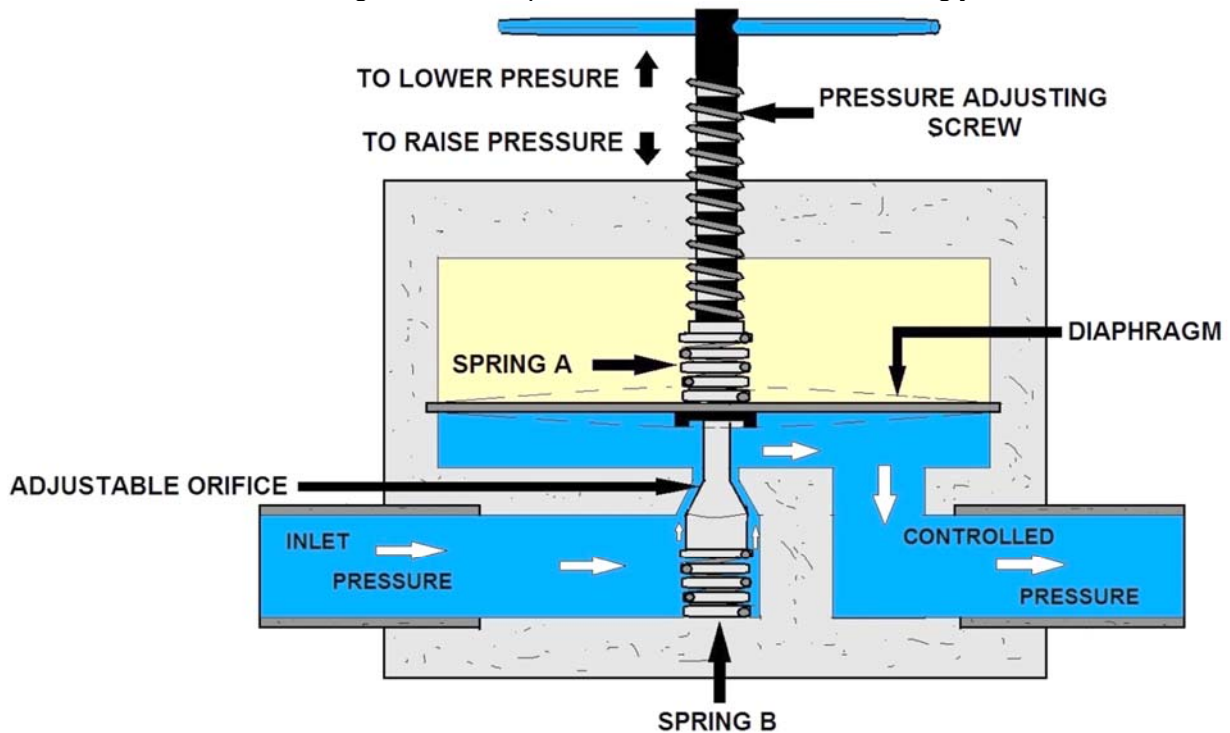

PRESSURE-REGULATING VALVE

Needle Valves *Rotary Valve*

A needle valve, as shown on the right, is used to make relatively fine adjustments in the amount of fluid flow. The distinguishing characteristic of a needle valve is the long, tapered, needle-like point on the end of the valve stem. This "needle" acts as a disk. The longer part of the needle is smaller than the orifice in the valve seat and passes through the orifice before the needle seats. This arrangement permits a very gradual increase or decrease in the size of the opening. Needle valves are often used as component parts of other, more complicated valves. For example, they are used in some types of reducing valves.

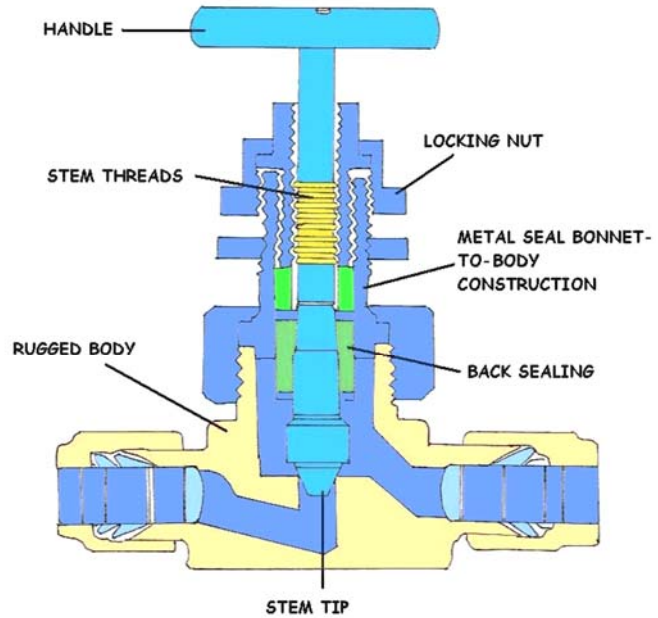

NEEDLE VALVE

Plug Valves *Rotary Valve*

Plug valves are extremely versatile valves that are found widely in low-pressure sanitary and industrial applications, especially petroleum pipelines, chemical processing and related fields, and power plants. They are high capacity valves that can be used for directional flow control, even in moderate vacuum systems. They can safely and efficiently handle gas and liquid fuel, and extreme temperature flow, such as boiler feed water, condensate, and similar elements. They can also be used to regulate the flow of liquids containing suspended solids (slurries).

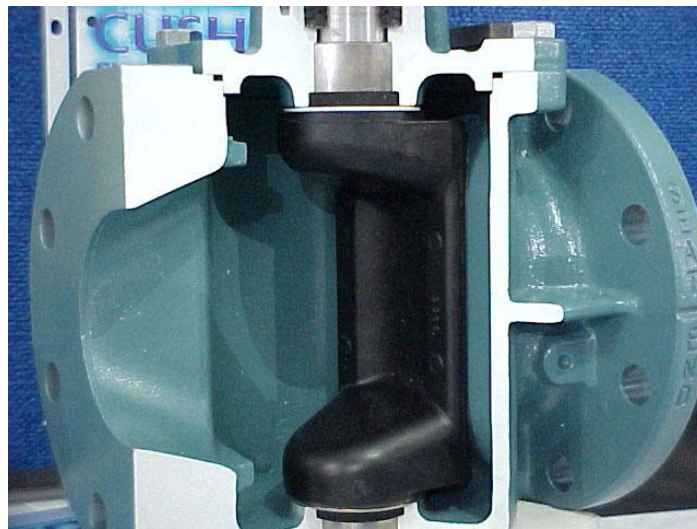

Cut-away of a Plug Valve

Angle Stop Rotary Valve

When working in tight areas, you sometimes need a tight fitting valve. This is an excellent place for an Angle Stop or Angle valve. If you ever have to jump an Angle valve on hot, first dismantle the bottom compression fitting and the rubber and slide it on the water line. Sometimes the bottom compression fitting will have a set-screw and some operators like to tighten it to the pipe or service before jumping the stop. Either way, it will work. Always have a helper if jumping any service larger than 1 inch.



Get in there and jump that corp!

Ball or Corporation Stop Rotary Valve Small Valves 2 inches and smaller

Most commonly found on customer or water meters. All small backflow assemblies will have two Ball valves. It is the valve that is either fully on or fully off; and the one that you use to test the abilities of a water service rookie. The best trick is to remove the ball from the Ball valve and have a rookie **Jump a Stop**. The Corp is usually found at the water main on a saddle. Some people say that the purpose of the Corp is to regulate the service. I don't like that explanation. No one likes to dig up the street to regulate the service, and Ball valves are only to be used fully on or fully off.



Most ball valves are the quick-acting type. They require only a 90-degree turn to either completely open or close the valve. However, many are operated by planetary gears. This type of gearing allows the use of a relatively small handwheel and operating force to operate a fairly large valve. Always follow standard safety procedures when working on a valve.

The gearing does, however, increase the operating time for the valve. Some ball valves also contain a swing check located within the ball to give the valve a check valve feature. The brass ball valve is often used for house appliance and industry appliance, the size range is 1/4"-4". Brass or zinc is common for body, brass or iron for stem, brass or iron for ball, aluminum, stainless steel, or iron for handle including a Teflon seal in the ball housing.



Flush the pipeline before installing the valve. Debris allowed to remain in the pipeline (such as weld spatters, welding rods, bricks, tools, etc.) can damage the valve. After installation, cycle the valve a minimum of three times and re-torque bolts as required. Ensure that the valve is in the open position and the inside of the body bore of the valve body/body end is coated with a suitable spatter guard.



Bird's eye view of the coveted stainless steel ball.



Removing the ball is very difficult. I recommend that you always use pipe dope or Teflon tape when installing a Stop. I know a lot of you think that brass or bronze will make up the slack, but pipe dope, or Teflon dope or tape makes a nicer job and makes for an easier removal.

Butterfly Valve Rotary Valve

Usually a huge water valve found in both treatment plants and throughout the distribution system. If the valve is not broken, it is relatively easy to operate. It is usually accompanied with a Gate valve used as a by-pass to prevent water hammer. When I was a Valve man, it seemed that every Bypass valve was broken closed when near a Butterfly valve.

These are rotary type of valves usually found on large transmission lines. They may also have an additional valve beside it known as a "**bypass valve**" to prevent a water hammer.

Some of these valves can require 300-600 turns to open or close. Most Valvemen (or the politically correct term "Valve Operators") will use a machine to open or close a Butterfly Valve. The machine will count the turns required to open or close the valve.

Butterfly valves should be installed with the valve shaft horizontal or inclined from vertical. Always follow standard safety procedures when working on a valve.

The valve should be mounted in the preferred direction, with the "HP" marking. Thermal insulation of the valve body is recommended for operating temperatures above 392°F (200°C). The valve should be installed in the closed position to ensure that the laminated seal in the disc is not damaged during installation.



If the pipe is lined, make sure that the valve disc does not contact the pipe lining during the opening stroke. Contact with lining can damage the valve disc.



54 inch Butterfly valve on a huge transmission line. Nice job but no shoring, no ladder or valve blocking.



FEATURES & ADVANTAGES

AWWA C504, CLASS 150B, BUTTERFLY VALVES

BODY

Heavy duty cast iron furnished standard, with ductile iron available as an extra cost option. Flanged Valves are faced and drilled per ANSI B16.1, Class 125. Mechanical Joint Valves are machined per ANSI/AWWA C111/A21.11. Wafer Valves are machined to fit between ANSI B16.1, Class 125 flanges.

SHAFT

Corrosion resistant stainless steel per ASTM A276 Type 304 furnished standard or type 316 furnished as an extra cost option. One piece design on valves sizes 2" to 8" and two piece design 10" and up. Shafts are sized to meet AWWA C504 for Class 150B Butterfly Valves.

BEARINGS

(Upper and Lower) Fiberglass reinforced nylon bearings are low friction, self-lubricating and provide exceptionally long life.

DISC

Corrosion resistant ASTM A276, Type 316 stainless steel sizes 2", 4" and 6". High strength ASTM-A536, 65-45-12, ductile iron with a 316 stainless steel edge per AWWA C504 and fusion bond epoxy coating on sizes 8" and up. Streamlined lens-shaped disc provides minimum headloss. Discs are attached to shafts with 316 stainless steel tapered dowel pins.

SHAFT SEALS

(Upper and Lower) Buna-N (Nitrile) Chevron V backing is self adjusting and provides exceptionally long life.

RESILIENT BODY SEAT

Standard Material is Buna-N (Nitrile) Rubber, permanently bonded to the iron body and tested per AWWA Standard C504.

SELF CENTERING DISC-NO ADJUSTMENT NECESSARY

Plate molded into the vulcanized rubber body seat mates with machined flats on the disc to provide positive centering of the disc in the body. Accurate centering of the disc in the body assures maximum seat life.

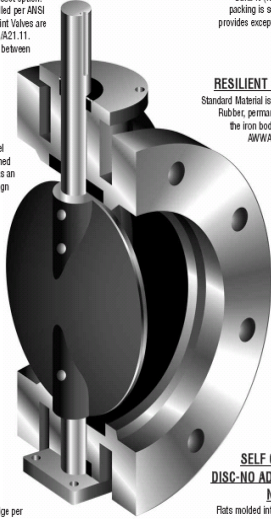

Bulletin BF150-2

AWWA STANDARD C-504 BUTTERFLY VALVES

FLANGED
WITH WORM GEAR
ACTUATOR & HANDWHEEL

WAFER
WITH 10 POSITION LEVER

M.J.
WITH TRAVELING NUT
ACTUATOR & 2" SQ. NUT

GA Industries Inc.

GA Industries Inc.

 MANUFACTURERS OF GOLDEN ANDERSON VALVES

ACTUATION METHODS



- Standard Handwheel
- Chainwheel Operated
- Square Nut
- Pneumatic
- Electric

Butterfly Valve Problems

A butterfly valve may have jerky operation for the following reasons:

If the packing is too tight--Loosen the packing torque until it is only hand tight. Tighten to the required level and then cycle the valve. Re-tighten, if required. CAUTION: Always follow safety instructions when operating on valve.

If the shaft seals are dirty or worn out--Clean or replace components, as per assembly-disassembly procedure. CAUTION: Always follow safety instructions when operating on a valve.

If the shaft is bent or warped--The shaft must be replaced. Remove valve from service and contact an outside contractor or your expert fix-it person.

If the valve has a pneumatic actuator, the air supply may be inadequate--Increase the air supply pressure to standard operating level. Any combination of the following may prevent the valve shaft from rotating:

If the actuator is not working--Replace or repair the actuator as required. Please contact specialized services or an outside contractor for assistance.

If the valve is packed with debris--Cycle the valve and then flush to remove debris. A full cleaning may be required if flushing the valve does not improve valve shaft rotation. Flush or clean valve to remove the debris.



A broken 54 inch Butterfly and a worker inside the water main preparing the interior surface. Notice, this is a Permit Required Confined Space. Hot work permit is also required. Side note, there is a plastic version of the 54 and 60 inch Butterfly valve.



Here at a water treatment plant, we can see both valve actuators control devices and Butterfly valves as well. Bottom photograph is a cut-away of an actuator.

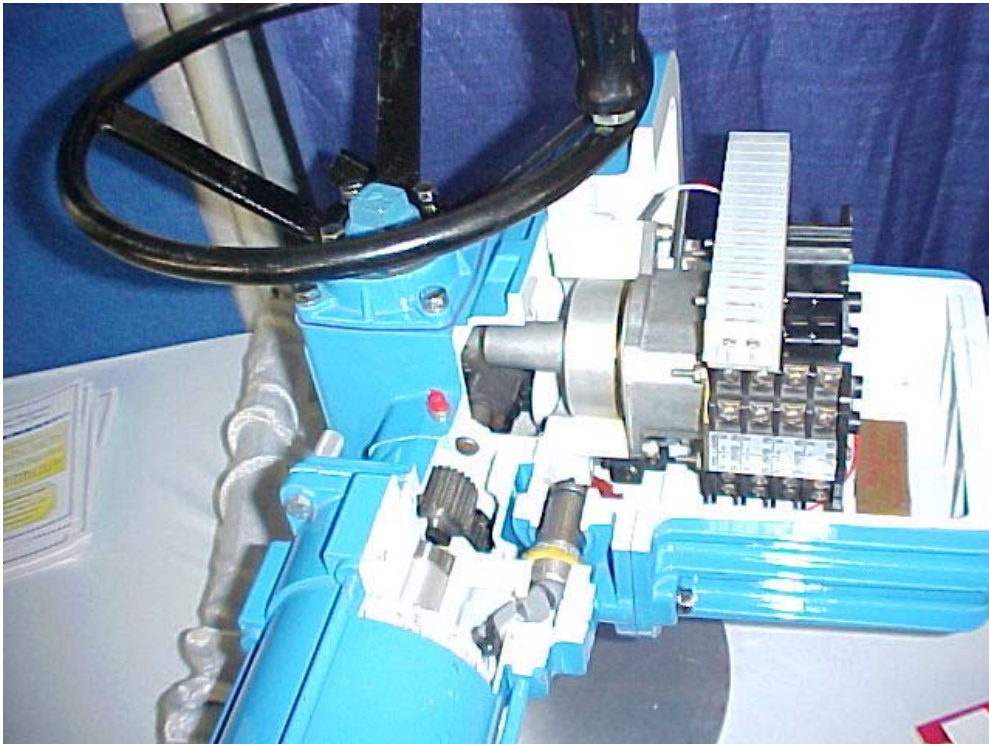

Actuators and Control Devices

Directional control valves route the fluid to the desired actuator. They usually consist of a spool inside a cast iron or steel housing. The spool slides to different positions in the housing, and intersecting grooves and channels route the fluid based on the spool's position.

The spool has a central (neutral) position maintained with springs; in this position the supply fluid is blocked, or returned to tank. Sliding the spool to one side routes the hydraulic fluid to an actuator and provides a return path from the actuator to the tank. When the spool is moved to the opposite direction, the supply and return paths are switched. When the spool is allowed to return to the neutral (center) position the actuator fluid paths are blocked, locking it in position.

Directional control valves are usually designed to be stackable, with one valve for each hydraulic cylinder, and one fluid input supplying all the valves in the stack.

Tolerances are very tight in order to handle the high pressure and avoid leaking; spools typically have a clearance with the housing of less than a thousandth of an inch. The valve block will be mounted to the machine's frame with a three point pattern to avoid distorting the valve block and jamming the valve's sensitive components.

The spool position may be actuated by mechanical levers, hydraulic pilot pressure, or solenoids which push the spool left or right. A seal allows part of the spool to protrude outside the housing, where it is accessible to the actuator.

The main valve block is usually a stack of off the shelf directional control valves chosen by flow capacity and performance. Some valves are designed to be proportional (flow rate proportional to valve position), while others may be simply on-off. The control valve is one of the most expensive and sensitive parts of a hydraulic circuit.

Pressure relief valves are used in several places in hydraulic machinery: on the return circuit to maintain a small amount of pressure for brakes, pilot lines, etc.; on hydraulic cylinders, to prevent overloading and hydraulic line/seal rupture; on the hydraulic reservoir, to maintain a small positive pressure which excludes moisture and contamination.

Pressure reducing valves reduce the supply pressure as needed for various circuits.

Sequence valves control the sequence of hydraulic circuits; to insure that one hydraulic cylinder is fully extended before another starts its stroke, for example.

Shuttle valves provide a logical function.

Check valves are one way valves, allowing an accumulator to charge and maintain its pressure after the machine is turned off, for example.

Pilot controlled Check valves are one way valves that can be opened (for both directions) by a foreign pressure signal. For instance, if the load should not be held by the check valve anymore. Often the foreign pressure comes from the other pipe that is connected to the motor or cylinder.

Counterbalance valves. A counterbalance valve is, in fact, a special type of pilot controlled check valve. Whereas the check valve is open or closed, the counterbalance valve acts a bit like a pilot controlled flow control.

Cartridge valves are, in fact, the inner part of a check valve; they are off the shelf components with a standardized envelope, making them easy to populate a proprietary valve block. They are available in many configurations: on/off, proportional, pressure relief, etc. They generally screw into a valve block and are electrically controlled to provide logic and automated functions. Hydraulic fuses are in-line safety devices designed to automatically seal off a hydraulic line if pressure becomes too low, or safely vent fluid if pressure becomes too high.

Auxiliary valves. Complex hydraulic systems will usually have auxiliary valve blocks to handle various duties unseen to the operator, such as accumulator charging, cooling fan operation, air conditioning power, etc... They are usually custom valves designed for a particular machine, and may consist of a metal block with drilled ports and channels. Cartridge valves are threaded into the ports and may be electrically controlled by switches or a microprocessor to route fluid power as needed.

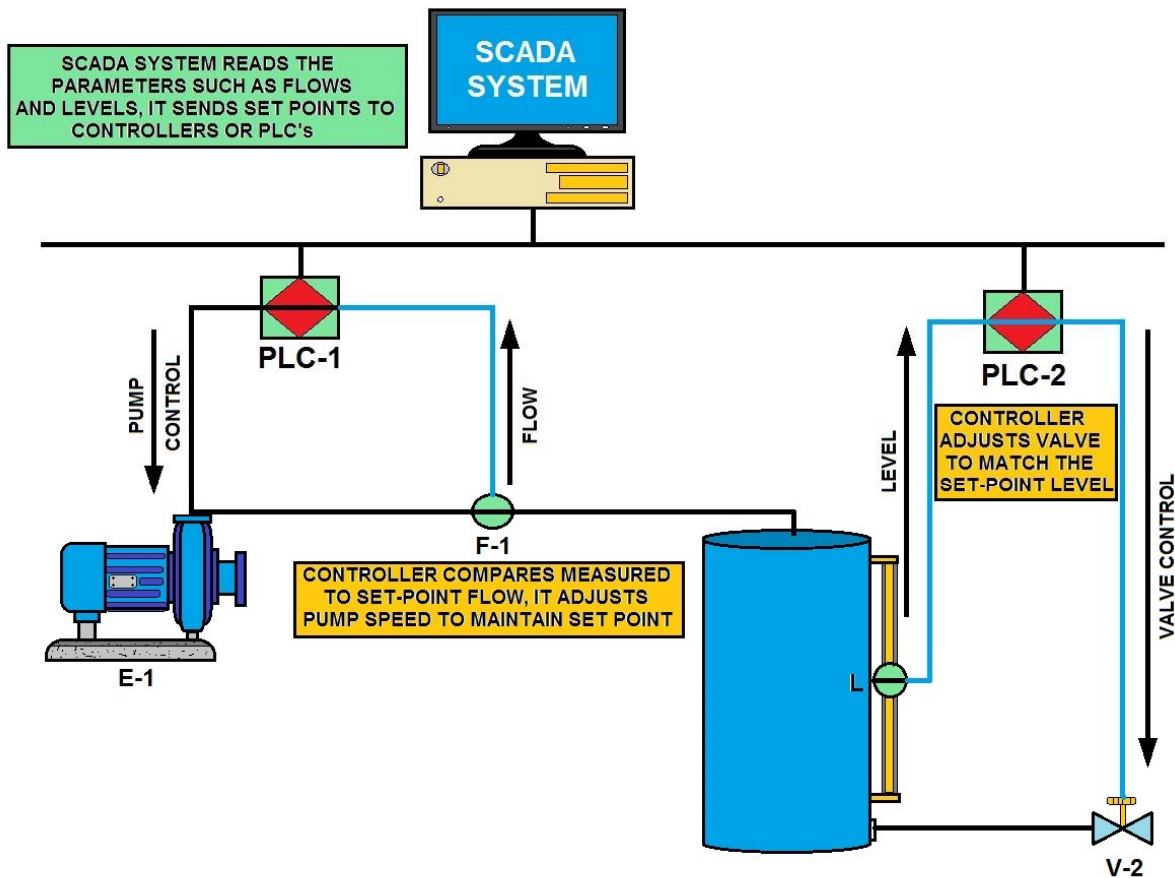

SCADA SYSTEM
(SUPERVISORY CONTROL and DATA ACQUISITION)

Why use automatic air valves?

- Increase flow capacity
- Reduce pumping costs (less electricity)
- Lessen the effect of water hammer.
- Prevent vacuum damage, such as pipeline collapse, seal failure, contamination and cross connection.
- Keep the lines full to reduce corrosion of the pipe.

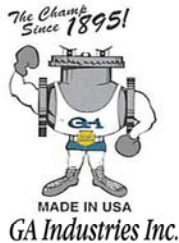

Air pockets reduce the cross sectional area of the pipe available to transmit the fluid, similar to partially closed valves. The velocity will increase at all air pockets and therefore the system head loss also increases.

The flow in the pipeline will push the air pocket down the pipe. The location of air valves should be at the point of the anticipated air pocket during flowing conditions.

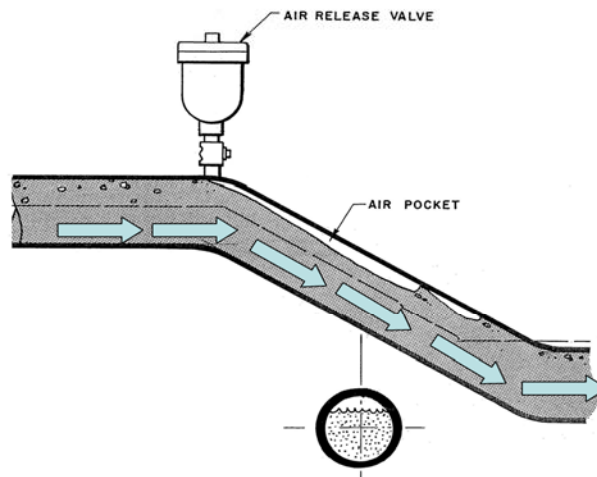

COMBINATION AIR VALVE

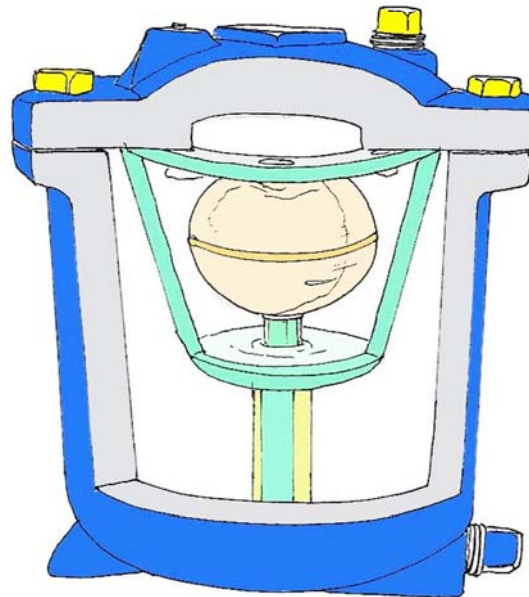
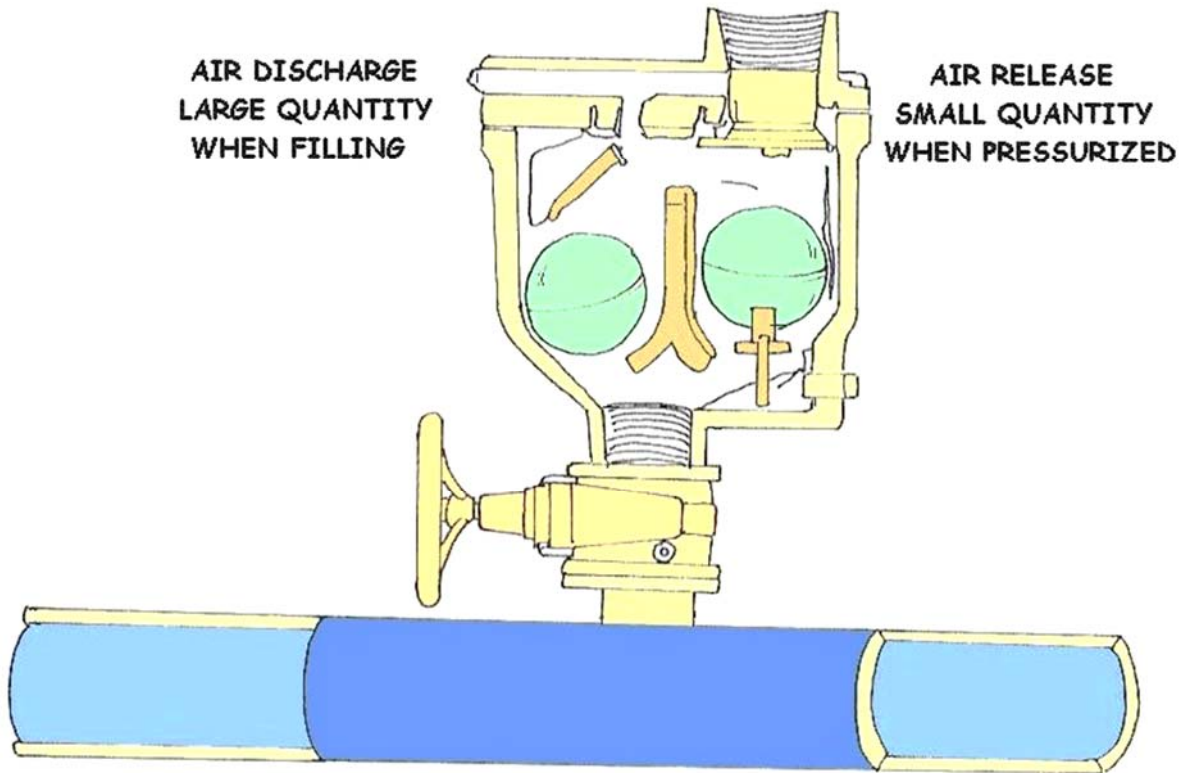

INTERNAL VIEW OF COMBINATION AIR VALVE

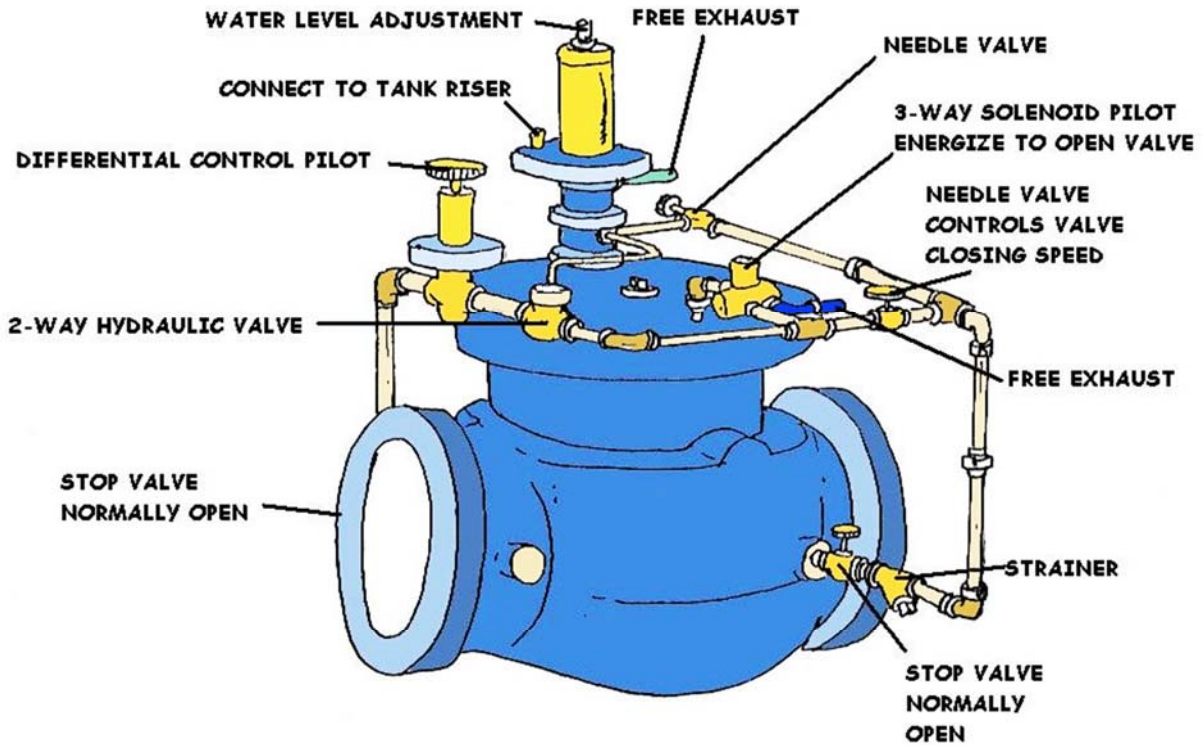

ALTITUDE CONTROL VALVE

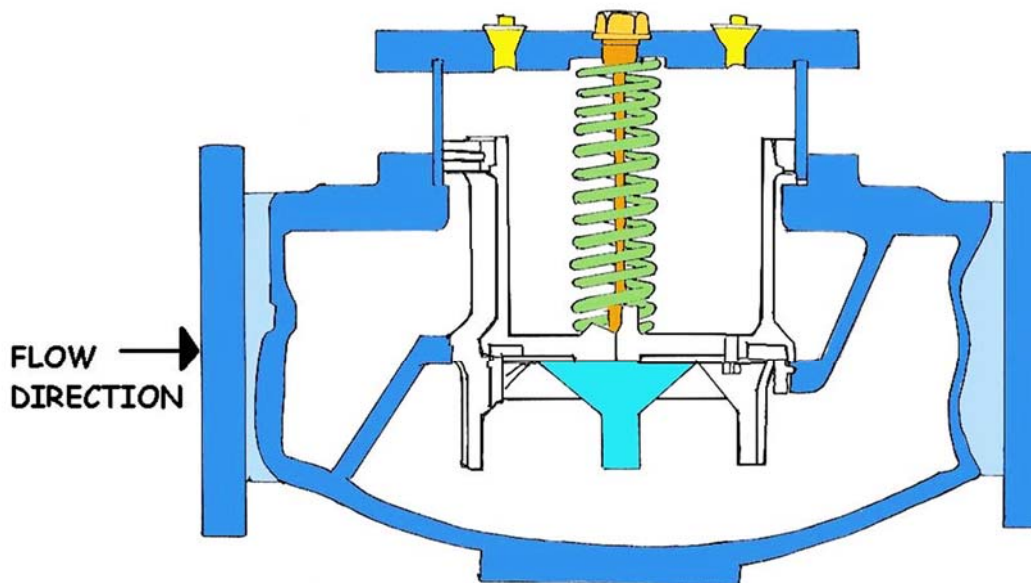

FLANGED GLOBE STYLE PRESSURE REDUCING VALVE

REDUCED PRESSURE VALVE OPERATION
(VALVE CLOSED)

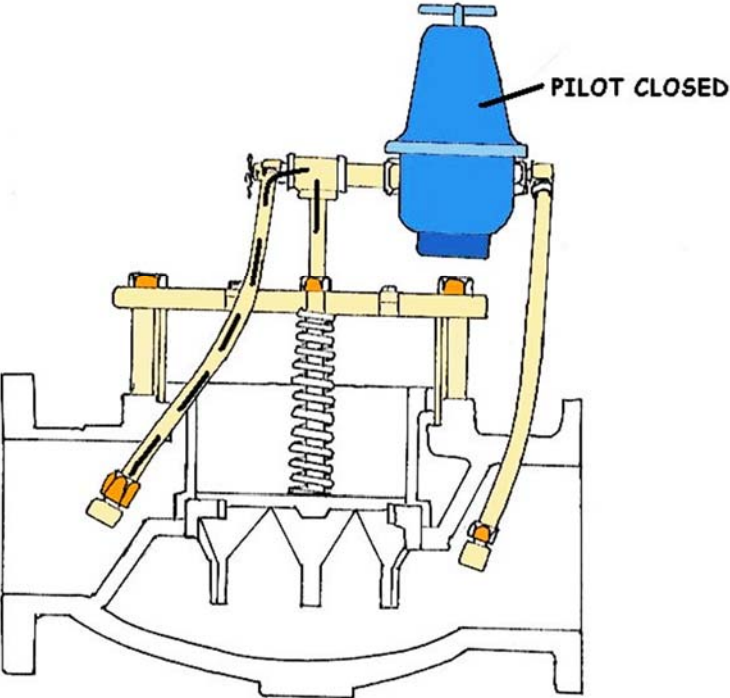

REDUCED PRESSURE VALVE OPERATION
(VALVE OPEN)

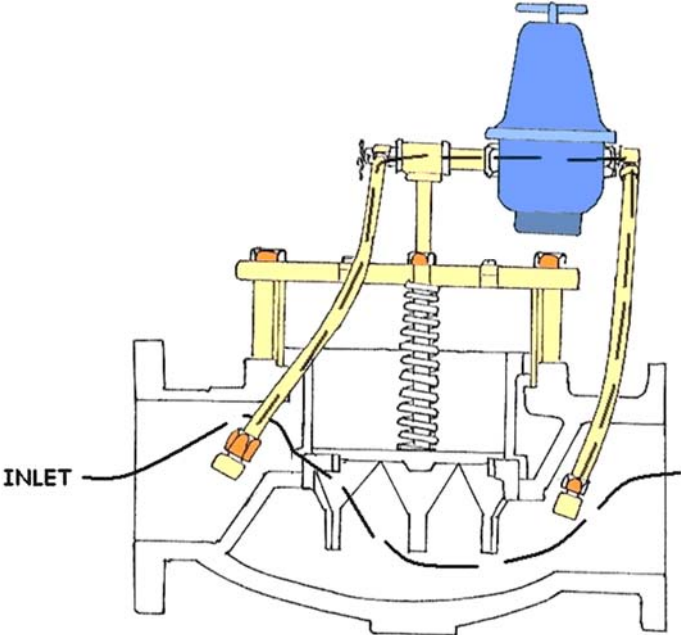

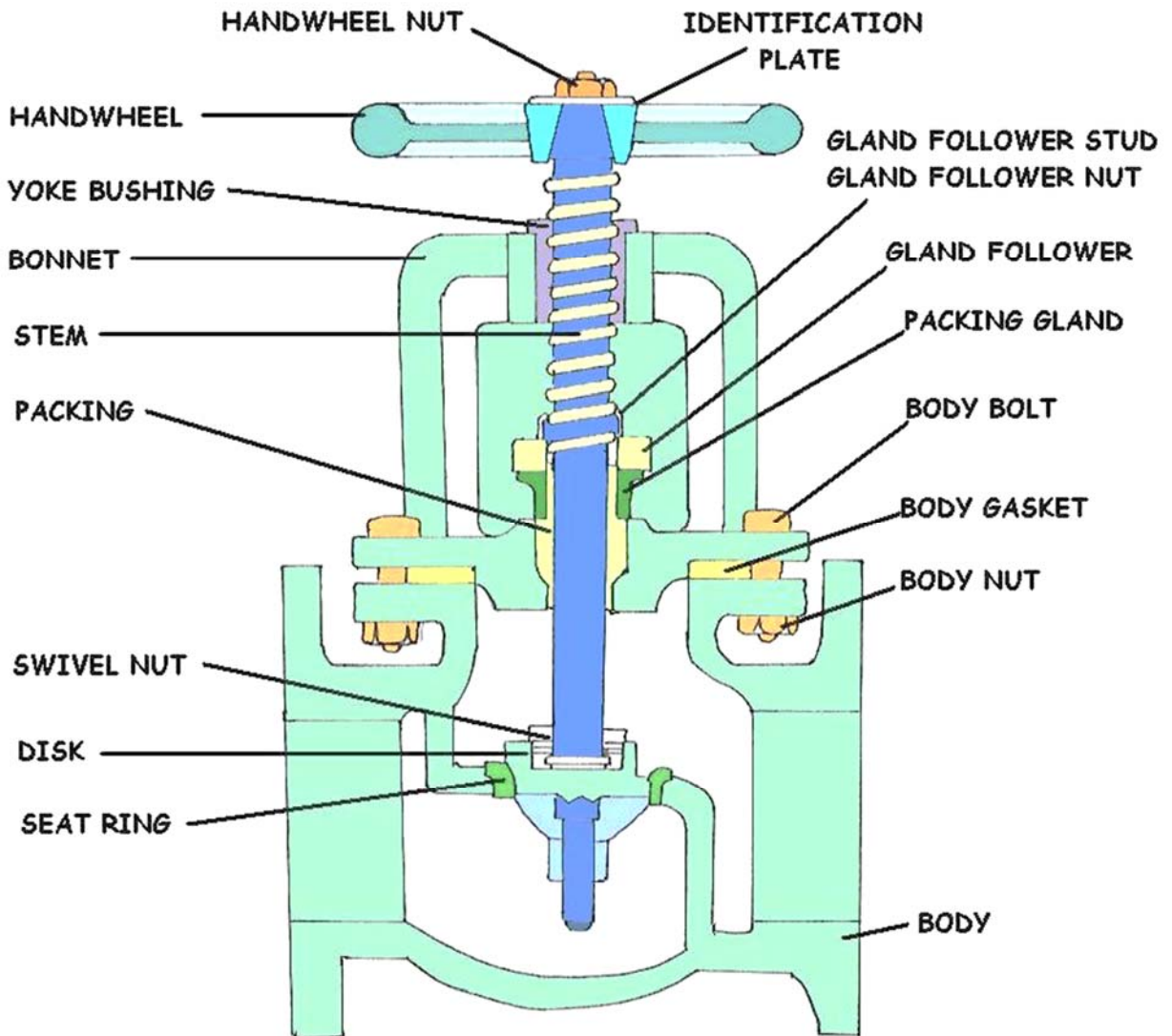

Friction Loss

Water will still be distributed through the system if a single section fails. The damaged section can be isolated and the remainder of the system will still carry water.

Water supplied to fire hydrants will feed from multiple directions. Thus during periods of peak fire flow demand, there will be less impact from "friction loss" in water mains as the velocity within any given section of main will be less since several mains will be sharing the supply.

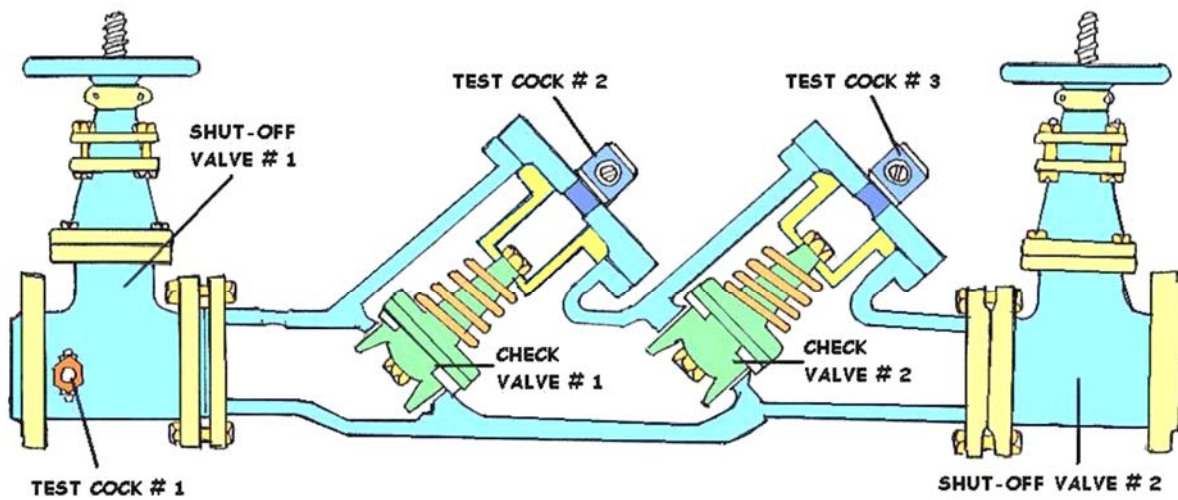

DOUBLE-CHECK BACKFLOW ASSEMBLY

REDUCED-PRESSURE BACKFLOW ASSEMBLY

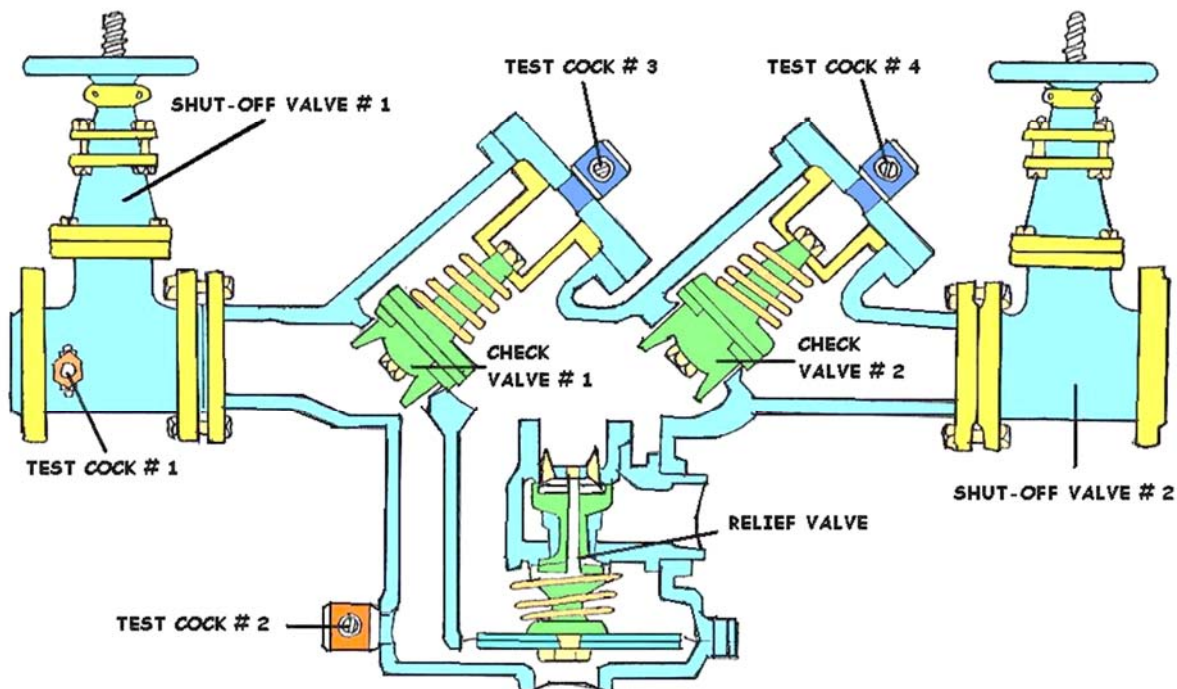

Pressure Reducing Valves *Rotary Valve*

Pressure Relief Valve

Pressure relief valves are used to release excess pressure that may develop as a result of a sudden change in the velocity of the water flowing in the pipe.

PRVs assist in a variety of functions, from keeping system pressures safely below a desired upper limit to maintaining a set pressure in part of a circuit. Types include relief, reducing, sequence, counterbalance, and unloading. All of these are normally closed valves, except for reducing valves, which are normally open. For most of these valves, a restriction is necessary to produce the required pressure control. One exception is the externally piloted unloading valve, which depends on an external signal for its actuation.

The most practical components for maintaining secondary, lower pressure in a hydraulic system are pressure-reducing valves. Pressure-reducing valves are normally open, 2-way valves that close when subjected to sufficient downstream pressure. There are two types: direct acting and pilot operated.

Direct acting - A pressure-reducing valve limits the maximum pressure available in the secondary circuit regardless of pressure changes in the main circuit, as long as the work load generates no back flow into the reducing valve port, in which case the valve will close.

The pressure-sensing signal comes from the downstream side (secondary circuit). This valve, in effect, operates in reverse fashion from a relief valve (which senses pressure from the inlet and is normally closed). As pressure rises in the secondary circuit, hydraulic force acts on area A of the valve, closing it partly. Spring force opposes the hydraulic force, so that only enough oil flows past the valve to supply the secondary circuit at the desired pressure. The spring setting is adjustable.

When outlet pressure reaches that of the valve setting, the valve closes, except for a small quantity of oil that bleeds from the low-pressure side of the valve, usually through an orifice in the spool, through the spring chamber, to the reservoir. Should the valve close fully, leakage past the spool could cause pressure build-up in the secondary circuit. To avoid this, a bleed passage to the reservoir keeps it slightly open, preventing a rise in downstream pressure above the valve setting. The drain passage returns leakage flow to reservoir. (Valves with built-in relieving capability also are available to eliminate the need for this orifice.)

Constant and fixed pressure reduction - Constant-pressure-reducing valves supply a preset pressure, regardless of main circuit pressure, as long as pressure in the main circuit is higher than that in the secondary. These valves balance secondary-circuit pressure against the force exerted by an adjustable spring which tries to open the valve. When pressure in the secondary circuit drops, spring force opens the valve enough to increase pressure and keep a constant reduced pressure in the secondary circuit. Fixed pressure reducing valves supply a fixed amount of pressure reduction regardless of the pressure in the main circuit. For instance, assume a valve is set to provide reduction of 250 psi. If main system pressure is 2,750 psi, reduced pressure will be 2,500 psi; if main pressure is 2,000 psi, reduced pressure will be 1,750 psi.

This valve operates by balancing the force exerted by the pressure in the main circuit against the sum of the forces exerted by secondary circuit pressure and the spring. Because the pressurized areas on both sides of the poppet are equal, the fixed reduction is that exerted by the spring.

How do Pressure Relief Valves Operate?

Most pressure relief valves consist of a main valve and pilot control system. The basic main Cla-Val valve is called a Hytrol Valve.

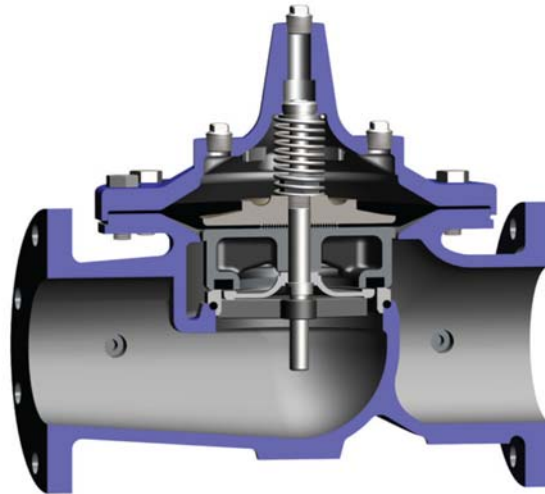

When no pressure is in the valve, the spring and the weight of the diaphragm assembly hold the valve closed.

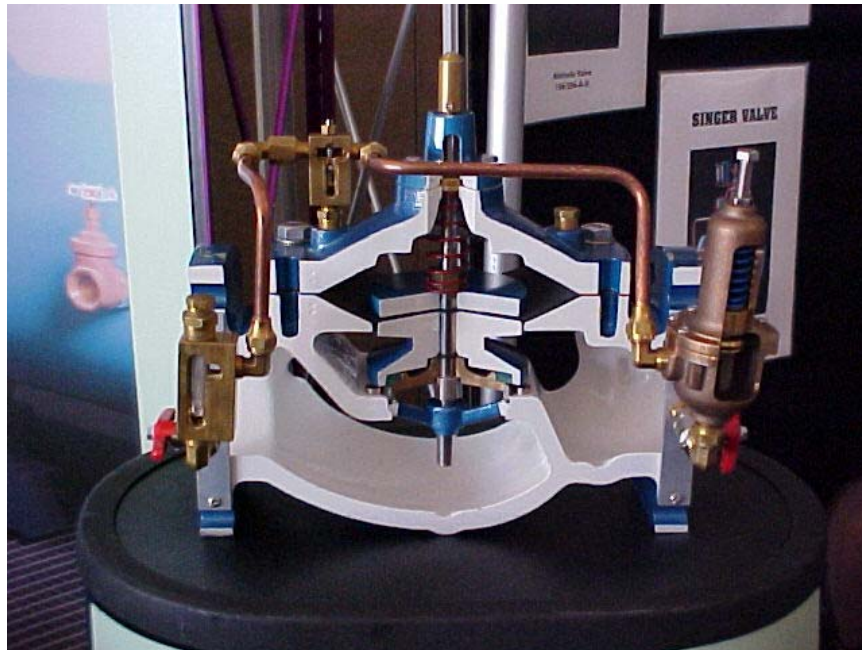

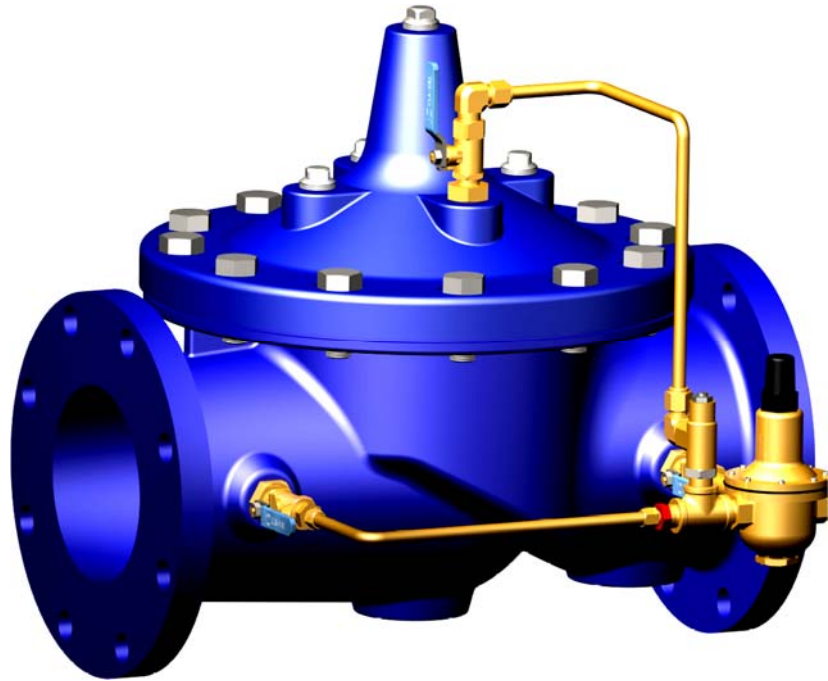

Pressure Reducing Valve Cla-Val 90 Series

- Holds downstream pressure to a pre-determined limit.
- Optional check feature.
- Fully supported frictionless diaphragm.



Pressure Reducing/Pressure Sustaining Control Valve Cla-Val 92 Series

- Maintains downstream pressure regardless of fluctuating demand and sustains upstream pressure to a pre-set minimum.
- Optional check feature.

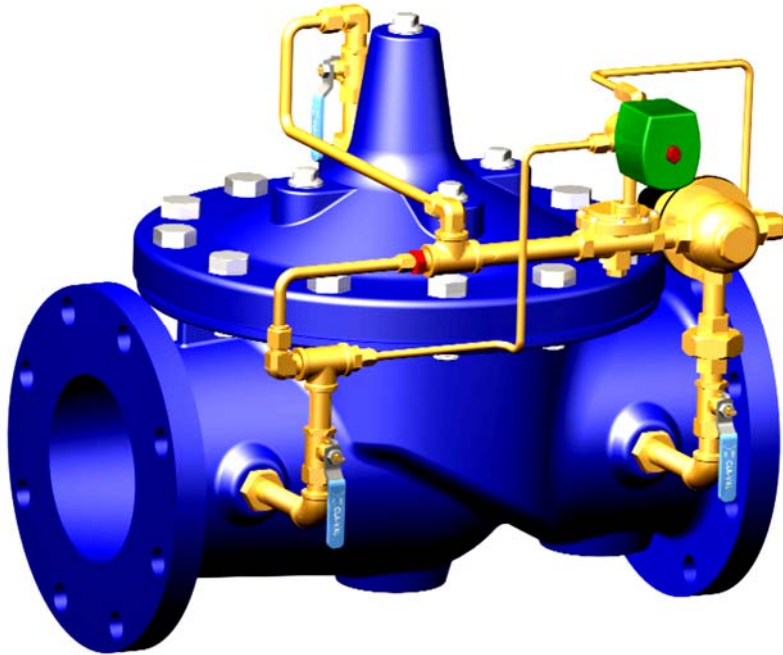

Pressure Reducing & Solenoid Shut-Off Valve Cla-Val 93 Series

- Ideal for reducing high transmission line pressures to lower distribution system pressures.
- Solenoid can be remotely activated.

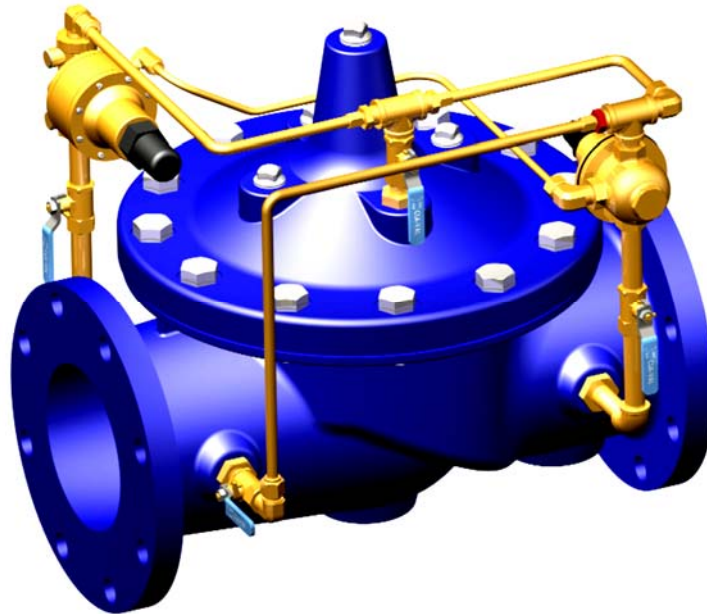

Pressure Reducing & Surge Control Valve Cla-Val 94 Series

- Integral surge pilot opens to prevent rapid pressure increases.
- Optional check feature.

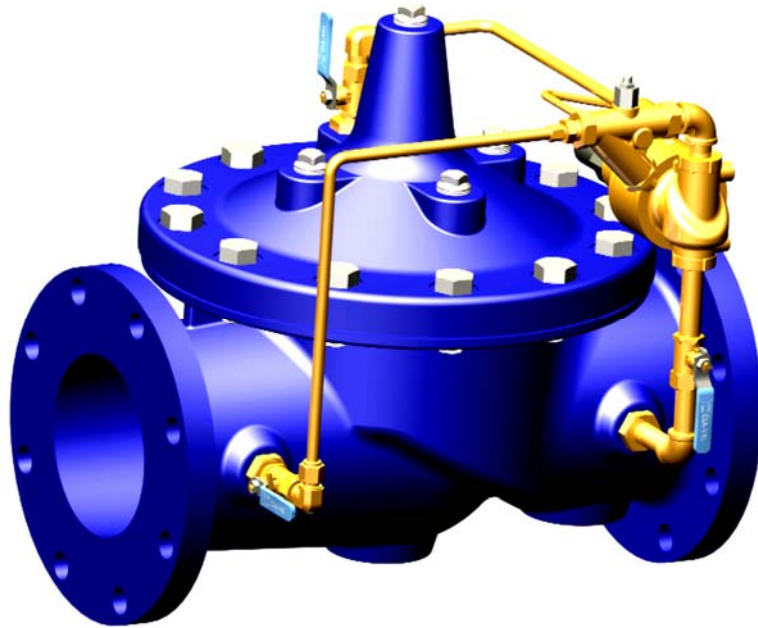

Pressure Relief/Pressure Sustaining Valve Cla-Val 50 Series

- Completely automatic operation.
- Accurate pressure control.
- Fast opening maintains line pressure.
- Slow closing prevents surges.
- Optional check feature.

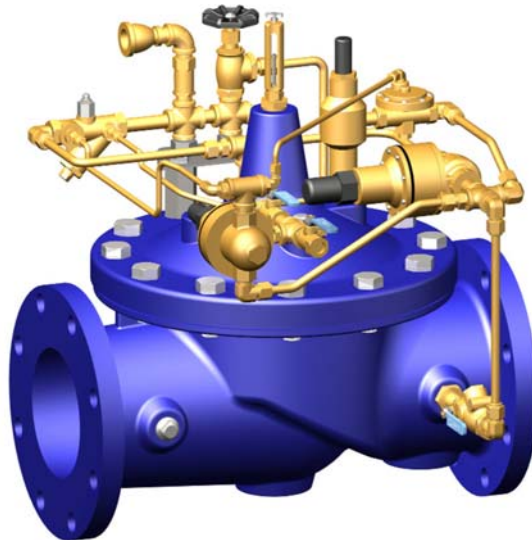

Surge Anticipator Valve Cla-Val 52 Series

- Protects pumping equipment and pipelines from damage caused by rapid flow velocity changes.
- Opens on initial low pressure wave.
- Closes slowly to prevent subsequent surges.



Float Valve Cla-Val 124 Series

- Accurate and repeatable level control in tanks to pre-set high and low points
- Reliable drip-tight shut-off.
- On-Off non-modulating action.
- Use Model 428-01 for modulating service.

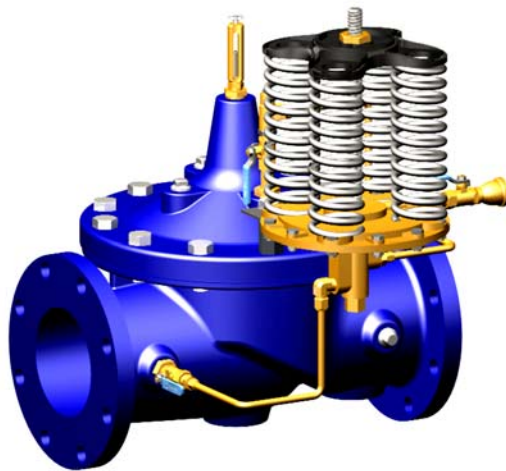

Altitude Control Valve Cla-Val 210 Series

- Provides accurate and repeatable tank level control.
- Optional check valve feature.
- Delayed opening option available.
- One-way and two-way flow pilot systems available.

SERIES 2000 Features

1. Full-ported for high capacity
2. Stainless trim - Standard
3. Stainless steel vee-ports for precise low flow control
4. 1- 1/2" through 3" - Screwed NPT connections
2" through 12" - 125# Flanged connections
5. Globe or angle body, both use identical internal parts
6. Only one moving part
7. No rubber diaphragms to fatigue, rot, rupture or fail.
8. Drop-tight closure
9. Streamlined body for low inherent headloss
10. 100% tested for reliability
11. Easily maintained in the line
12. Many options available

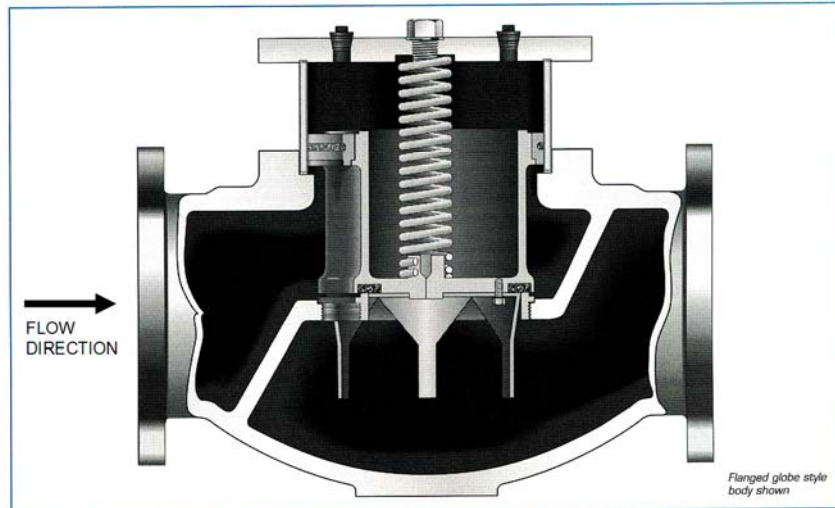

SERIES 2000 Features

1. Full-ported for high capacity
2. Stainless trim - Standard
3. Stainless steel vee-ports for precise low flow control
4. 1- 1/2" through 3" - Screwed NPT connections
2" through 12" - 125# Flanged connections
5. Globe or angle body, both use identical internal parts
6. Only one moving part
7. No rubber diaphragms to fatigue, rot, rupture or fail.
8. Drop-tight closure
9. Streamlined body for low inherent headloss
10. 100% tested for reliability
11. Easily maintained in the line
12. Many options available

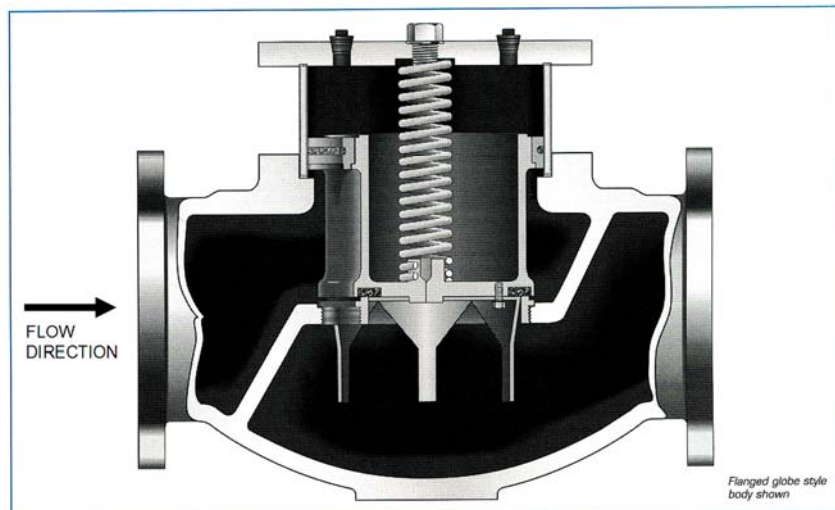

Pressure Reducing Valve Operation

SERIES 2000 pressure reducing valves will throttle to maintain a steady downstream pressure as set by the pilot spring adjustment. The valve will close drip-tight when the downstream pressure exceeds the pilot setting.

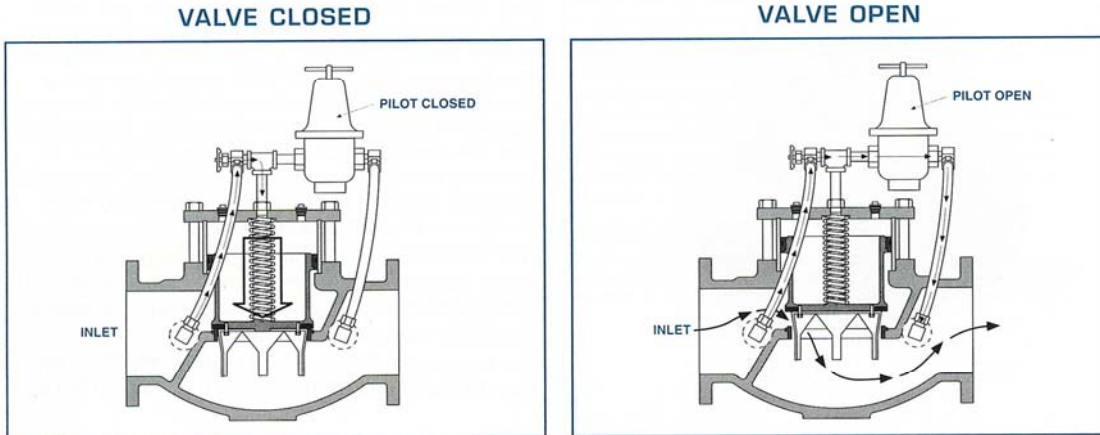
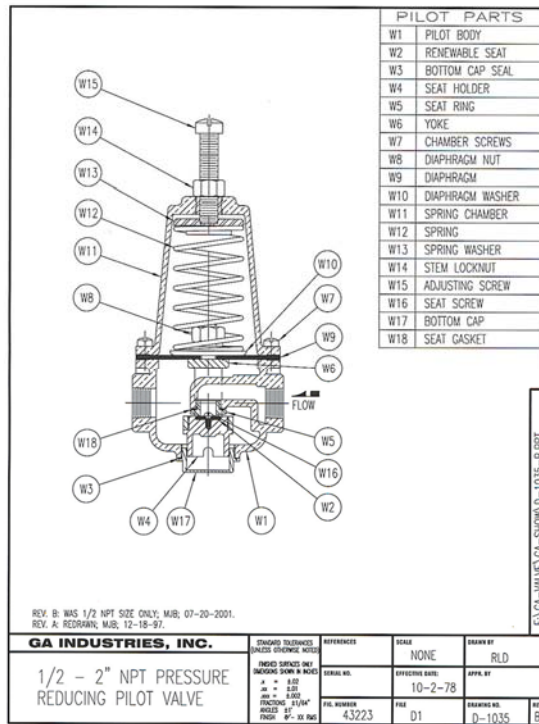

Figure 1. Valve closed when downstream pressure exceeds pilot setting

The valve is installed with flow "over the seat." Inlet pressure is conveyed to the top of the piston by means of a small pilot line and a closing speed control needle valve. Downstream pressure is applied to the underside of the pilot valve's diaphragm and is opposed by the pilot's adjusting spring. The pilot closes when the downstream pressure exceeds the adjusting spring set point, allowing inlet pressure to build on the upper surface of the piston and hold the main valve closed.

Figure 2. Valve throttles to satisfy demand at setting of pilot

Should downstream pressure fall to the setting of the pilot spring, the pilot opens and allows flow from above the piston to the downstream side of the valve at a faster rate than can be applied through the inlet needle valve. This reduces the pressure on the upper surface of the piston so that inlet pressure, which is constantly applied to the underside of the piston, lifts the piston and opens the main valve. The pilot "throttles" the main valve, allowing sufficient flow to match demand in order to maintain the downstream pressure as determined by the pilot setting.



Valve Exercising Section

Valve exercising should be done once per year (especially main line valves) to detect malfunctioning valves and to prevent valves from becoming inoperable due to freezing or build-up of rust or corrosion. A valve inspection should include drawing valve location maps to show distances (ties) to the valves from specific reference points (telephone poles, stonelines, etc.).

Hydrants are designed to allow water from the distribution system to be used for fire-fighting purposes.



Bottom of a dry barrel fire hydrant--there is a drainage hole on the back of this hydrant, sometimes referred to as a "weep hole". Below is an "Airport Runway" type of hydrant. These are difficult to find.

Here are Common Valve Operation Problems

Valve stem is improperly lubricated or damaged--I always liked to find a bent brass stem. Just a small bend will make most valves difficult to operate. This also applies to misplaced valve boxes. It is best to disassemble the valve and inspect the stem. Acceptable deviation from theoretical centerline created by joining center points of the ends of the stem is 0.005"/ft of stem. Inspect the threads for any visible signs of damage. Small grooves less than 0.005" can be polished with an Emory cloth. Contact specialized services or an outside contractor if run-out is unacceptable or large grooves are discovered on the surface of the stem.

Valve packing compression is too tight--Verify the packing bolt torque and adjust if necessary.

Foreign debris is trapped on threads and/or in the packing area--This is a common problem when valves are installed outdoors in sandy areas and in areas not cleaned before operating. Always inspect threads and packing area for particle obstructions; even seemingly small amounts of sand trapped on the drive can completely stop large valves from cycling. The valve may stop abruptly when a cycle is attempted. With the line pressure removed from the valve, disconnect the actuator, gear operator or handwheel and inspect the drive nut, stem, bearings and yoke bushing.

Contaminated parts should be cleaned with a lint-free cloth using alcohol, varsol or the equivalent. All parts should be re-lubricated before re-assembly. If the valves are installed outdoors in a sandy area, it may be desirable to cover the valves with jackets.

Valve components are faulty or damaged-- contact the supply house or warehouse. Most valve salesmen will try to keep your business and do whatever is possible to do so. In the last ten years only one manufacturer did not replace a faulty valve. It is one of the largest makers of water valves and blew me off. It was clearly a bad valve to begin with. Sad part of this story is that the large American valve companies have to deal with aggressive Chinese valve companies that will make things right to keep your business. Most of these valves that I have seen are great for most water and wastewater work. They have nice finishes and even come in stainless steel--Probably made from recycled American cars. I just hate to switch over to anything other than American but I guess we are living in a Global market.

The handwheel is too small--Increasing the size of the handwheel will reduce the amount of torque required to operate the valve. If a larger handwheel is installed, the person operating the valve must be careful not to over-torque the valve when closing it. Most Valve operators will have a set of special keys for the operation of most valves but a small wheel can present problems as well as no hand wheel.

Dr. Rusty's commentary, Over the years and at most systems, it seems that the institutional knowledge that most of the old timers have is priceless and under appreciated by most management. The reason I say this is most experienced Valvemen or Valve Operators know their system better than any map or GIS system. Don't throw these people under the bus!

Slam, Surge and Water Hammer

When a valve is closed *instantaneously* there is a corresponding *instantaneous* pressure rise, causing a water hammer.

Water hammer (or, more generally, fluid hammer) is a pressure surge or wave caused by the kinetic energy of a fluid in motion when it is forced to stop or change direction suddenly. It depends on the fluid compressibility where there are sudden changes in pressure. For example, if a valve is closed suddenly at the end of a pipeline system, a water hammer wave propagates in the pipe. Moving water in a pipe has kinetic energy proportional to the mass of the water in a given volume times the square of the velocity of the water.

The Effects of Water Hammer And Pulsations

Quick closing valves, positive displacement pumps, and vertical pipe runs can create damaging pressure spikes, leading to blown diaphragms, seals and gaskets, and also destroyed meters and gauges.

Liquid, for all practical purposes, is not compressible: any energy that is applied to it is instantly transmitted. This energy becomes dynamic in nature when a force such as a quick closing valve or a pump applies velocity to the fluid.

Surge (Water Hammer)

Surge (or water hammer, as it is commonly known) is the result of a sudden change in liquid velocity. Water hammer usually occurs when a transfer system is quickly started, stopped or is forced to make a rapid change in direction. Any of these events can lead to catastrophic system component failure. Without question, the primary cause of water hammer in process applications is the quick closing valve, whether manual or automatic. A valve closing in 1.5 sec. or less depending upon valve size and system conditions causes an abrupt stoppage of flow. The pressure spike (acoustic wave) created at rapid valve closure can be high as five(5) times the system working pressure.

For this reason, most pipe-sizing charts recommend keeping the flow velocity at or below 5 ft/s (1.5 m/s). If the pipe is suddenly closed at the outlet (downstream), the mass of water before the closure is still moving forward with some velocity, building up a high pressure and shock waves. In domestic plumbing this is experienced as a loud bang resembling a hammering noise. Water hammer can cause pipelines to break or even explode if the pressure is high enough. Air traps or stand pipes (open at the top) are sometimes added as dampers to water systems to provide a cushion to absorb the force of moving water in order to prevent damage to the system. (At some hydroelectric generating stations, what appears to be a water tower is actually one of these devices.) The water hammer principle can be used to create a simple water pump called a hydraulic ram.

On the other hand, when a valve in a pipe is closed, the water downstream of the valve will attempt to continue flowing, creating a vacuum that may cause the pipe to collapse or implode. This problem can be particularly acute if the pipe is on a downhill slope. To prevent this, air and vacuum relief valves, or air vents, are installed just downstream of the valve to allow air to enter the line and prevent this vacuum from occurring.

Unrestricted, this pressure spike or wave will rapidly accelerate to the speed of sound in liquid, which can exceed 4000 ft/sec. It is possible to estimate the pressure increase by the following formula.

Water Hammer Formula: $P = (0.070) (V) (L) / t + P1$

Where P = Increase in pressure
P1 = Inlet Pressure
V = Flow velocity in ft/sec
t = Time in sec.(Valve closing time)
L = Upstream Pipe Length in feet

Here's an example of pressure hammer when closing an EASMT solenoid valve, with a 50 ft long upstream pipe connection:

L = 50 ft
V = 5.0 ft / sec(recommended velocity for PVC piping design)
t = 40 ms(solenoid valve closing time is approx. 40-50 ms)
P1 = 50 psi inlet pressure

therefore, $P = 0.07 \times 5 \times 50 / 0.040 + P1$
or $P = 437.5 \text{ psi} + P1$

Total Pressure = $437.5 + 50 = 487.5 \text{ psi}$

Pulsation

Pulsation generally occurs when a liquid's motive force is generated by reciprocating or peristaltic positive displacement pumps. It is most commonly caused by the acceleration and deceleration of the pumped fluid. This uncontrolled energy appears as pressure spikes. Vibration is the visible example of pulsation and is the culprit that usually leads the way to component failure.

Unlike centrifugal pumps(which produce normally non-damaging high-frequency but low-amplitude pulses), the amplitude is the problem because it's the pressure spike. The peak, instantaneous pressure required to accelerate the liquid in the pipe line can be greater than ten (10) times the steady state flow pressure produced by a centrifugal pump. Damage to seals gauges, diaphragms, valves and joints in piping result from the pressure spikes created by the pulsating flow.

Remedy

Suggest that you install a pulsation dampener or surge tank. Dampeners provide the most cost efficient and effective choice to prevent the damaging effects of pulsation. A surge suppressor is in design essentially the same as pulsation dampener. The difference primarily lies in sizing and pressurizing. The most current pulsation dampener design is the hydro-pneumatic dampener, consisting of a pressure vessel containing a compressed gas, generally air or Nitrogen separated from the process liquid by a bladder or diaphragm.

Types of Pipes Used in the Water Distribution Field

Several types of pipe are used in water distribution systems, but only the most common types used by plumbers and operators will be discussed. These piping materials include copper, plastic, galvanized steel, and cast iron. Some of the main characteristics of pipes made from these materials are presented below.

Plastic Pipe (PVC)

Plastic pipe has seen extensive use in current construction. Available in different lengths and sizes, it is lighter than steel or copper and requires no special tools to install. Plastic pipe has several advantages over metal pipe: it is flexible; it has superior resistance to rupture from freezing; it has complete resistance to corrosion; and, in addition, it can be installed aboveground or below ground.

One of the most versatile plastic and polyvinyl resin pipes is the polyvinyl chloride (PVC). PVC pipes are made of tough, strong thermoplastic material that has an excellent combination of physical and chemical properties. Its chemical resistance and design strength make it an excellent material for application in various mechanical systems.

Sometimes polyvinyl chloride is further chlorinated to obtain a stiffer design, a higher level of impact resistance, and a greater resistance to extremes of temperature. A CPVC pipe (a chlorinated blend of PVC) can be used not only in cold-water systems, but also in hot-water systems with temperatures up to 210°F. Economy and ease of installation make plastic pipe popular for use in either water distribution and supply systems or sewer drainage systems.



Various types and sizes of coupons or tap cut-outs. You will want to date and collect these cut-outs to determine the condition of the pipe or measure the corrosion.

Plastic Pipe (PVC)

This is currently the most common type of pipe used in distribution systems. It is available in diameters of 1/2" and larger, and in lengths of 10', 20', and 40'. A main advantage is its light weight, allowing for easy installation. A disadvantage is its inability to withstand shock loads. Since it is non-metallic, a tracer wire must be installed with the PVC water main so that it can be located after burial.

The National Sanitation Foundation (NSF) currently lists most brands of PVC pipe as being acceptable for potable water use. This information should be stamped on the outside of the pipe, along with working pressure and temperature, diameter and pipe manufacturer.

PVC pipe will have the highest C Factor of all the above pipes. The higher the C factor the smoother the pipe.

Cast Iron (CIP)

This is another type of piping material that has been in use for a long time. It is found in diameters from 3" to 48". Advantages of this material are its long life, durability and ability to withstand working pressures up to 350 psi. Disadvantages include the fact that it is heavy, difficult to install and does not withstand shock loading. Although it is not currently the material of choice, there is still a lot of it in the ground.

Ductile Iron Pipe (DIP)

This was developed to overcome the breakage problems associated with cast iron pipe. It can be purchased in 4" to 45" diameters and lengths of 18' to 20'. Its main advantage is that it is nearly indestructible by internal or external pressures. It is manufactured by injecting magnesium into molten cast iron.

It is sometimes protected from highly corrosive soils by wrapping the pipe in plastic sheeting prior to installation. This practice can greatly extend the life of this type of pipe.

Steel Pipe

This pipe is often used in water treatment plants and pump stations. It is available in various diameters and in 20' or 21' lengths. Its main advantage is the ability to form it into a variety of shapes. It also exhibits good yielding and shock resistance. It has a smooth interior surface and can withstand pressures up to 250 psi. A disadvantage is that it is easily corroded by both soil and water.

To reduce corrosion problems, steel pipe is usually galvanized or dipped in coal-tar enamel and wrapped with coal-tar impregnated felt. At present, however, coal-tar products are undergoing scrutiny from a health standpoint and it is recommended that the appropriate regulatory agencies be contacted prior to use of this material.

Asbestos Cement Pipe (ACP)

This pipe is manufactured from Portland cement, long fibrous asbestos and silica. It is available in diameters from 3" to 36" and in 13' lengths. Its main advantages are its ability to withstand corrosion and its excellent hydraulic flow characteristics due to its smoothness.

A major disadvantage is that it is brittle and is easily broken during construction or by shock loading. There is some concern regarding the possible release of asbestos fibers in corrosive water and there has been much debate over the health effects of ingested asbestos. Of greater concern, however, is the danger posed by inhalation of asbestos fibers.

Asbestos is considered a hazardous material, and precautionary measures must be taken to protect water utility workers when cutting, tapping or otherwise handling this type of pipe.

Galvanized Pipe

Galvanized pipe is commonly used for the water distributing pipes inside a building to supply hot and cold water to the fixtures. This type of pipe is manufactured in 21-ft lengths. It is GALVANIZED (coated with zinc) both inside and outside at the factory to resist corrosion. Pipe sizes are based on nominal INSIDE diameters. Inside diameters vary with the thickness of the pipe. Outside diameters remain constant so that pipe can be threaded for standard fittings.

Copper

Copper is one of the most widely used materials for tubing. This is because it does not rust and is highly resistant to any accumulation of scale particles in the pipe. This tubing is available in three different types: K, L, and M.

K has the thickest walls, and M, the thinnest walls, with L's thickness in between the other two. The thin walls of copper tubing are soldered to copper fittings. Soldering allows all the tubing and fittings to be set in place before the joints are finished. Generally, faster installation will be the result.

Type K copper tubing is available in either rigid (hard temper) or flexible (soft temper) and is primarily used for underground service in the water distribution systems. Soft temper tubing is available in 40- or 60-ft coils, while hard temper tubing comes in 12- and 20-ft straight lengths. Type L copper tubing is also available in either hard or soft temper and either in coils or in straight lengths. The soft temper tubing is often used as replacement plumbing because of the tube's flexibility, which allows easier installation.

Type L copper tubing is widely used in water distribution systems.

Type M copper tubing is made in hard temper only and is available in straight lengths of 12 and 20 ft. It has a thin wall and is used for branch supplies where water pressure is low, but it is *NOT* used for mains and risers. It is also used for chilled water systems, for exposed lines in hot-water heating systems, and for drainage piping.



PVC in top photograph. ABS plastic pipe in bottom. It is strange that some States allow ABS and others do not. Like with any subject, it all depends on politics.



Soldering Copper Tubing

These are the basics to sweating or soldering copper tubing. Copper sweating is easy to do and after this chapter or if you watch the video presentation you will be without an excuse to fix all of your leaky outside faucets.

First, we are start with proper safety equipment. This includes long-sleeved shirts, work boots, eye protection and leather gloves. Copper tubing has sharp edges and will cut you. Be careful handling the tubing. There is the chance that you will be burned also. Be careful of the torch and the pipe. Do not hand your project to another person unless they are wearing gloves. More advice, do not or try not to solder directly on top of finished cement. Sometimes, water can be in the pores of the cement. It is difficult to see, and the cement may look completely dry, but your torch will find the smallest drop of water and make the water into steam and create a small explosion. This usually will happen in the morning causing small particles of concrete to spray in to your eyes.

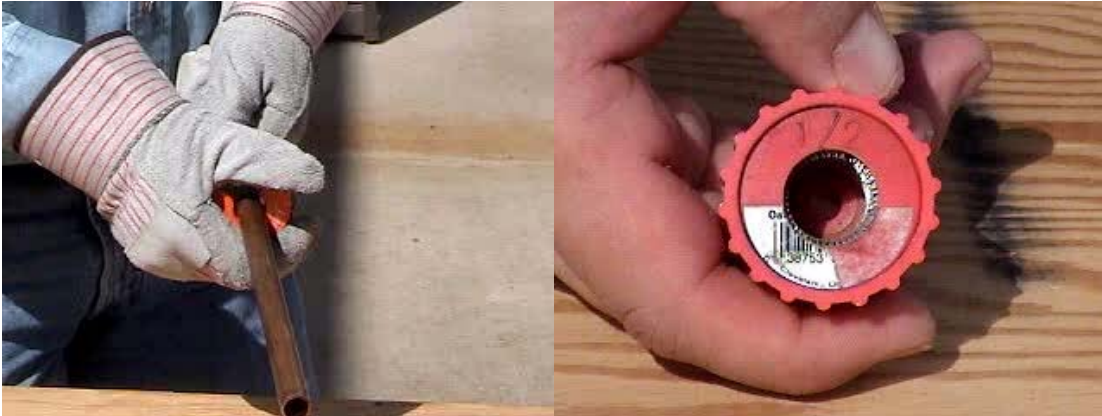

Methods or tools for cutting the tubing.

The first one is a simple copper tubing cutter. Just simply snug the cutter on the pipe and turn the cutter. Tighten or snug the cutter a little more and turn again until the pipe has been cut in two. Simple. Do not force the pipe cutter or thread the pipe. You must be careful not to break the little cutter's wheel.

Here is a new type of copper cutter in the top left side picture. Just simply snap the tool on the pipe and twist.

Next we are going to ream the tubing of its sharp edges. This is necessary to prevent turbulence in the pipe which can create a pinhole leak. This is a common occurrence at 90s.

Now we are going to remove the oxidation from the pipe with a battery terminal type of cleaner. Just a wire brush inside a round plastic holder. You can see this in the top right hand side picture. You could also use sandpaper or steel wool to accomplish this necessary procedure. Next we are going to use flux. You need to use a little brush and apply a light coat of flux to the end of your tubing. The flux is needed so that the hot solder can be sucked into the joint and create a full seal.

Once the flux has been applied you can connect your fittings. We suggest that you twist your fittings to get the flux to be properly spread on the fitting and pipe end surfaces. They say that flux is not hazardous or corrosive, but for some reason it seems to eat holes in clothes.



Propane gas will work fine for half inch tubing, but it doesn't work well with the larger pipe sizes. Propane seems to take just a minute longer than map gas.

Place the flame nozzle just about one inch from the 90, focusing the heat right in the middle of the fitting. Take a piece of solder about twelve inches or so, and test the area. If the fitting is hot enough, it will draw the solder and equally distribute it around the joint. This should take about one second or so.

MAP gas is a hotter gas made of oxygen and acetylene. MAP gas works fast and the soldering is done quickly. Remember that your project is hot and be prepared to be burned if you are not careful.

Most common mistake that you will make.

This mistake is burning the flux out of the joint before you are able to apply solder. I call this burning the joint. If you overheat the joint and burn the flux, you will see the joint steaming and turning black, as you apply the solder, the solder just drips off the pipe. If this happens to you, cool the pipe off and re-sand, re-apply flux and do it again.

Another Problem

Another common problem with soldering is water. If you have one drop of water in the line, you will not be able to get a good seal. There are a couple of tricks to help you solder when there is water in the line. One method is plain old white bread. Just cram the water line with bread until the water has stopped. You can proceed to solder your fitting at that time and then simply flush the line when you are finished. There are also small balls filled with oil that you can cram inside the pipe, or you can even freeze the pipe to sweat your fittings on. You can also purchase a special tool from most plumbing stores that works like a compression fitting or a boat drain plug and will stop the leak.

Distribution Joints and Fittings

Fittings vary according to the type of piping material used. The major types commonly used in water service include elbows, tees, unions, couplings, caps, plugs, nipples, reducers, and adapters. Besides bell-and-spigot joints, cast-iron water pipes and fittings are made with either flanged, mechanical, or screwed joints. The screwed joints are used only on small-diameter pipe.

Tapping Sleeve



Gate Valves are used to isolate sections of water mains. Not to be used to throttle or regulate the flow.

A Globe valve should be used to regulate the flow. Be sure to chlorinate or disinfect all distribution parts such as valves.

Caps

A pipe cap is a fitting with a female (inside) thread. It is used like a plug, except that the pipe cap screws on the male thread of a pipe or nipple.

Couplings

The three common types of couplings are straight coupling, reducer, and eccentric reducer. The STRAIGHT COUPLING is for joining two lengths of pipe in a straight run that does not require additional fittings. A run is that portion of a pipe or fitting continuing in a straight line in the direction of flow.

A REDUCER is used to join two pipes of different sizes. The ECCENTRIC REDUCER (also called a BELL REDUCER) has two female (inside) threads of different sizes with centers so designed that when they are joined, the two pieces of pipe will not be in line with each other, but they can be installed to provide optimum drainage of the line.

Elbows (OR ELLS) 90° AND 45°

These fittings (fig. 8-5, close to middle of figure) are used to change the direction of the pipe either 90 or 45 degrees. **REGULAR** elbows have female threads at both outlets.

STREET elbows change the direction of a pipe in a closed space where it would be impossible or impractical to use an elbow and nipple. Both 45 and 90-degree street elbows are available with one female and one male threaded end. The REDUCING elbow is similar to the 90-degree elbow except that one opening is smaller than the other is.

Nipples

A nipple is a short length of pipe (12 in. or less) with a male thread on each end. It is used for extension from a fitting. At times, you may use the DIELECTRIC or INSULATING TYPE of fittings. These fittings connect underground tanks or hot-water tanks. They are also used when pipes of dissimilar metals are combined. These help slow down corrosion that starts inside the pipe and works to the outside of the pipe.

Do not heat or solder dielectric fittings. You may melt the plastic coating from them.

Zinc is a coating on the outside and inside of pipes to slow corrosion. This is called "galvanization".

Tees

A tee is used for connecting pipes of different diameters or for changing the direction of pipe runs. A common type of pipe tee is the STRAIGHT tee, which has a straight-through portion and a 90-degree takeoff on one side.



Notice the type of pipe connection device.
This is known as a "Restraining Flange".

All three openings of the straight tee are of the same size. Another common type is the REDUCING tee, similar to the straight tee just described, except that one of the threaded openings is of a different size than the other.

Unions

There are two types of pipe unions. The GROUND JOINT UNION consists of three pieces, and the FLANGE UNION is made in two parts. Both types are used for joining two pipes together and are designed so that they can be disconnected easily joined, the two pieces of pipe will not be in line with each other, but they can be installed to provide optimum drainage of the line.

Water Main Installation

Installation of new or replacement pipe sections should be in accordance with good construction practices. The line must be buried a minimum of 30" below the ground surface to prevent freezing. The line must be bedded and backfilled properly insuring protection from weather and surface loadings. Also, thrust blocking (*Kickers*) at all bends, tees, and valves is essential to hold the pipe in place and prevent separation of line sections. Thrust blocking is not necessary if the pipe is welded.

Disinfection of new installations or repaired sections is required prior to placing them in service. This can be accomplished by filling the line with a 25 mg/L free chlorine solution and allowing it to stand for 24 hours. Valves and fittings used in the waterworks industry are made of cast iron, steel, brass, stainless and fiberglass.

Enough gate valves should be placed throughout the system to enable problem areas (leaks, etc.) to be isolated and repaired with minimal service disruption.

Air relief valves should be installed at highpoints in the system. Valves should be installed with valve boxes and covers.

Regardless of the type of pipe installed, certain maintenance routines should be performed on the distribution system to maintain water quality and optimal service. These programs should be scheduled and performed on a regular basis.

Flushing at blowoffs on dead end lines and at fire hydrants throughout the system should be done at least twice per year. Flushing is needed to remove stagnant water in dead ends and to remove accumulated sediment that results from turbidity, iron, manganese, etc. This should also help minimize customer complaints of water quality.

Flushing should always be done from the source to the ends of the system. Affected customers should be notified of this process in advance. To do an adequate job of flushing, the flow should reach a velocity of at least 2.5 feet per second, known as the "minimum cleansing velocity" of the system (at hydrant locations).

These tests are important to determine the adequacy of the distribution system in transmitting water, particularly during days of peak demand. Also, these tests can help determine if pipe capacity is decreasing over time due to internal corrosion or deposits.

Pressure tests should be done at various locations in the distribution system several times per year. This helps to monitor the performance of the system and alert the operator to problems such as leaks or internal deposits. It is sometimes advantageous to have certain points in the system continuously monitored to provide a constant evaluation of the system.





Installation of a new customer water service line.



Cathodic Protection

Steel reservoirs can be subject to internal corrosion through the process of electrolysis which occurs when metallic ions are released by the steel and flow through the water, which is electrically conductive. This can be overcome by installing a “sacrificial anode,” usually composed of magnesium or zinc, in the water and connecting it to the positive side of a DC power source.

The wall of the reservoir is connected to the negative side of the power supply. This tends to reverse the flow of electrons, from the anode (hence the term sacrificial), through the water and back to the reservoir wall.

This essentially turns the steel wall of the reservoir into a cathode, or negative terminal, with respect to its surroundings, and the migration of metallic ions from the steel is retarded.



Repair crew replacing three tapping valves that blew out during a leak.

Miscellaneous

Sump Pump

If you have a sump pump, be sure that it is always in good operating condition so that it will be ready to function when it is needed. Oil it carefully in accordance with the manufacturer's instructions. Make it operate occasionally by tripping the lever after filling the basin particularly with water. Unless you do this every three or four months, there is danger that corrosion may cause a sticking of the shaft when operation is required.



Sump Pump

Backwater Valve

The function of this valve is to prevent the sewer from backing up into the house during heavy rains. Most backwater valves operate automatically. A valve with a butterfly action closes against the sewer on the house side. Sometimes however, debris lodges against the seat of the valve so that it cannot close tightly. There are also manually operated valves that have a wheel handle to shut them down.

Sometimes, debris (mop strings, etc.) can accumulate or collect near the valve seat, which prevents it from closing tightly. With automatic backwater valves, removing the lid, cleaning the seat, and greasing the hinge pin on the valve gate annually will guarantee that the valve will operate as expected when it is called upon to prevent the water from coming into your basement. With the manual type of valve it is best to operate this valve every six months in order that (1) all members of the family may be familiar with the location of the valve with its function, and where the wheel for manual operation is stored; and (2) in order that the manual operation may keep the valve free from corrosion and lessen the chances for debris interfering with the valve closing.

Flammable Vapors

Vapors from flammable liquids can explode and catch fire, causing death or severe burns. That is why it's vitally important, that you should NEVER use flammable liquids such as gasoline, adhesive solvents, lighter fluid, mineral spirits, paint thinner and kerosene around water heaters, furnaces, or any appliance with the potential for flame or sparks. Keep flammable products far away from the water heater or furnace, stored in an approved container, tightly closed and out of children's' reach. Flammable products, improperly stored or used near an open flame, give off invisible vapors that can travel the length of a house and be ignited by any of a dozen or more household sources of flame or spark. A few precautionary measures can prevent a tragedy from taking place.

Water Service Pipe Installation – Assignment Question 1

a) Underground Water Service.

Water service pipe shall be installed outside the foundation wall.

1) Water service and building drain or building sewer may be installed in separate trenches with a minimum of 10 feet horizontal separation. Such installation shall use material listed in Approved Materials for Building Sewer and Approved Materials for Water Service Pipe, provided that such material is specific for this type of installation.

2) The water service and the building drain or building sewer may be installed in the same trench provided that the water service is placed on a solid shelf a minimum of 18 inches above the building drain or building sewer. For such installation, the building sewer shall be of material listed in Approved Building Drainage/Vent Pipe for a building drain.

3) The minimum depth for any water service pipe shall be at least 36 inches or the maximum frost penetration of the local area, whichever is of greater depth.

4) No water service pipe shall be installed or permitted outside of a building or in an exterior wall unless provisions are made to protect such pipe from freezing.

b) Potable Water Piping and Sanitary Sewer Crossing Installation Requirements.

1) Where it is necessary for the potable water piping to pass above or below a sanitary sewer, such piping shall be installed with a minimum vertical separation of 18 inches for a distance of 10 feet on either side from the center of the sanitary sewer.

2) Where it is necessary for the potable water piping to pass beneath a sanitary sewer or drain, the sanitary sewer or drain shall be constructed of materials as specified in Approved Building Drainage/Vent Pipe for building drains, and shall extend on each side of the crossing to a distance of at least 10 feet as measured at right angles to the water line.

3) Wet/Dry Bore:

When it is not possible to comply with subsection (b)(1) or (2), a pressure rated pipe approved for building drain material shall encase the water service pipe. The casing pipe shall be sealed with a casing seal and extend 10 feet on either side of the center of the sanitary sewer pipe. The sleeve or case shall be at least 2 times the size of the water service.

c) When it is not possible to comply with subsection (a) or (b), the Department shall be contacted for consideration of alternative methods.

d) Stop-And-Waste Valve. Combination stop-and-waste valves and cocks shall not be installed in an underground potable water pipe. Frost free hydrants and fire hydrants shall not be considered stop-and-waste valves.

Potable Water Pumping and Storage Equipment

a) Pumps and Other Appliances. Potable water pumps, tanks, filters, and all other appliances and devices shall be protected against contamination.

b) Water Supply Tanks. Potable water supply tanks shall be properly covered to prevent contamination of the water supply. Soil or waste lines shall not pass directly over such tanks.

c) Cleaning, Painting, Repairing Water Tanks. A potable water supply tank used for domestic purposes shall not be lined, painted or repaired with any material which affects either the taste or the potability of the water. Tanks shall be disconnected from the system during such operations to prevent any foreign substance from entering the system.

Potable Water Supply Tanks and Auxiliary Pressure Tanks

Question 14

a) When the water pressure from the public water supply main is insufficient during periods of peak flow or due to the building height to supply all fixtures, the rate of supply shall be supplemented by a gravity tank or auxiliary pressure (booster) system. Auxiliary pressure systems shall not substitute for adequate sizing of water distribution piping within the building.

b) Support. All water supply tanks shall be supported in accordance with local building codes or other regulations that apply.

c) Tank Supply Inlet and Outlet. The water supply inlet to the tank shall have a minimum air gap of at least six (6) inches. The supply outlet shall be a minimum of four (4) inches above the bottom of the tank.

d) Overflow For Water Supply Tanks. Overflow pipes for gravity tanks shall be indirectly connected to the drainage system with an air gap of at least six (6) inches. Overflow pipes shall be full sized, unrestricted and screened with 24-mesh per inch stainless steel or bronze screen.

e) Size of Overflow. Overflow drains for gravity water supply tanks shall have an area of at least twice the size of the supply pipe.

f) Drains. Water supply tanks shall be provided with valved drain lines located at their lowest point and discharge through an indirect waste with an air gap of twice the diameter of the drain line. Such drain line and valve shall have no restrictions and need not exceed two (2) inches in diameter.

g) Gravity and Suction Tanks. Tanks used for potable water supply or to supply fire-fighting equipment only shall be equipped with tight, overlapping covers which are rodent and insect proof. Such tanks shall be vented with a return bend (turned down) pipe having an area at least one-half (1/2) the area of the tank outlet pipe, and the vent opening shall be covered with a stainless steel or bronze screen of at least 24-mesh per inch.

h) Pressure Tanks. Pressure tanks used for supplying water to the water distribution system, or to supply standpipes for fire equipment only, shall be equipped with a vacuum relief valve located on top of the tank. An air inlet of this device shall be covered with a stainless steel or bronze screen of at least 24-mesh per inch.

Water Supply Control Valves and Meter

- a) A full-port shut-off valve shall be located near the curb or property line and immediately inside the building, either on the inlet or outlet side of the water meter. When underground, this valve shall be located in a stop box or meter vault.
- b) The utility meter may be installed outside in an accessible meter vault or within the building. The meter shall have unions on the inlet/outlet openings, but is not required to have a shut-off valve on the inlet side of the meter if it is inside a building. A full-port valve with an open area at least that of the water service shall be provided for all meters.
- c) Tank Controls. Supply lines taken from pressure or gravity tanks shall be valved at or near their source.
- d) Water Heating Equipment. A shut-off valve shall be provided in the cold water branch line within 5 feet of each water storage tank or each water heater.
- e) Separate Controls for Each Family Unit. In multiple family dwellings, the water service or water distribution pipe to each family unit shall be controlled by an arrangement of shut-off valves which permits each group of fixtures and each individual fixture to be shut off without interference with the water supply to any other family unit or portion of the building. The location of such valves shall be uniform in each family unit of a multiple family dwelling.
- f) Buildings Other Than Dwellings. In all buildings other than dwellings and health care facilities as specified in subsection (g) of this Section, shut-off valves shall be installed to permit the water supply to all equipment and/or fixtures in each separate room to be shut off without interfering with the water supply to any other room or portion of the building. For plumbing equipment or fixtures that are installed back-to-back in adjacent rooms, e.g., in adjacent restrooms, a common shut-off valve may be used to shut off the water supply to the back-to-back fixtures in no more than 2 adjacent rooms.
- g) Health Care Facilities. In the residence rooms of health care facilities the water distribution pipe to each resident unit or back-to-back rooms shall be controlled by an arrangement of line valves that permits each group of fixtures, and each individual fixture, to be shut off without interference with the water supply to any other unit or portion of the building.

Flushing/Disinfection of Potable Water System Question 33

New or repaired potable water systems shall be flushed or disinfected prior to use as follows:

- a) Chlorinated Water Supply. If the potable water supply serving the water supply system is chlorinated, e.g., a community water system, the water supply system, or appropriate repaired portion, shall be flushed with clean, potable water until no dirty water appears at the point of outlet.
- b) Non-Chlorinated Water Supply. The pipe system shall be flushed with clean, potable water until no dirty water appears at the point of outlet.

1) The system (or part thereof) shall be filled with a chlorine solution containing at least 50 parts per million of chlorine, shall be valved off and allowed to stand for 24 hours; or the system (or part thereof) shall be filled with a chlorine solution containing at least 200 parts per million of chlorine and be allowed to stand for three (3) hours.

2) Following the required contact (standing) time, the system shall be flushed with clean, potable water until the chlorine level in the water discharging from the system is within acceptable limits for potable water, i.e., generally until the water has no detectable chlorine odor.

3) To ensure that the water supplied by the water system is safe for drinking, a bacteriological examination of a water sample taken from the water supply system shall be secured. This examination shall be performed by a laboratory certified in accordance with 35 Ill. Adm. Code 183. The chlorine residual in any water sample collected for such examination must not exceed four (4) parts per million (or 4 milligrams/liter) for a reliable laboratory result. If such examination reveals that contamination still persists in the system, the procedure outlined above for disinfection shall be repeated.

Water Service Sizing

a) **Water Service Pipe Sizing.** The water service pipe from the street main (including the tap) to the water distribution system for the building shall be sized in accordance with Appendix A, Tables M, N, O, P and Q. Water service pipe and fittings shall be at least $\frac{3}{4}$ inch diameter. Plastic water pipe shall be rated at a minimum of 160 psi at 73.4°F. If flushometers or other devices requiring a high rate of water flow are used, the water service pipe shall be designed and installed to provide this additional flow.

b) **Demand Load.** The calculation of the water service demand load for a building shall be based on the total number and types of fixtures installed in the building, assuming the simultaneous use of such fixtures.

c) **Unused sections of water service or water distribution piping ("dead ends"),** where the water in the piping may become stagnant, are prohibited. A developed length of more than 2 feet shall be considered a dead end.

Design of a Building Water Distribution System Question 41

a) **Design and Installation.** The design and installation of the hot and cold water building distribution systems shall provide a volume of water at the required rates and pressures to ensure the safe, efficient and satisfactory operation of fixtures, fittings, appliances and other connected devices during periods of peak use. No distribution pipe or pipes shall be installed or permitted outside of a building or in an exterior wall unless provisions are made to protect such pipe from freezing, including but not limited to wrap-on insulation or heat tape tracer line or wire.

b) **Size of Water Distribution Pipes.** The fixture supply for each fixture shall be at least the minimum size provided in Appendix A, Table D. The size of all other water distribution pipes shall be determined by calculating the water supply demand (in water supply fixture units) for that portion of the water distribution system served by the pipe. Using Appendix A, Tables M, N, O, P and Q, the cumulative water supply demand or load shall be calculated for all fixtures, piping, valves and fittings served by the water distribution pipe, and the pipe

shall meet the minimum size provided in Appendix A, Table N or O, as applicable. Exception: As an alternative to using Tables M, N, O, P and Q to design and size the piping in the water distribution system, the system may be designed and sized employing current engineering practices, provided the design/plans are approved in writing by an Illinois licensed professional engineer, an Illinois licensed architect or an individual Certified in Plumbing Engineering (C.I.P.E.) by the American Society of Plumbing Engineers and approved in writing by the Department.

c) Minimum Water Pressure. The minimum constant water service pressure on the discharge side of the water meter shall be (at least) 20 p.s.i.; and the minimum constant water pressure at each fixture shall be at least 8 p.s.i. or the minimum recommended by the fixture manufacturer.

d) Auxiliary Pressure. Supplementary Tank. If the pressure in the system is below the minimum 8 p.s.i. at the highest water outlet when the flow in the system is at peak demand, an automatically controlled pressure tank or gravity tank of a capacity to supply sections of the building installation which are too high to be supplied directly from the public water main shall be installed.

e) Low Pressure Cut-Off. When a booster pump except those used for fire protection is used on an auxiliary pressure system, there shall be installed a low-pressure cut-off switch on the booster pump to prevent the creation of pressures less than 5 p.s.i. on the suction side of the pump. A shut-off valve shall be installed on the suction side of the water system and within 5 feet from the pump suction inlet, and a pressure gauge shall be installed between the shut-off valve and pump.

f) Water Hammer. All building water supply systems shall be provided with air chambers or approved mechanical devices or water hammer arrestors to absorb high pressures. Water pressure absorbers shall be installed at the ends of long pipe runs or near batteries of fixtures.

1) Air Chambers. Where an air chamber is installed in a fixture supply, it shall be at least 12 inches in length and the same diameter as the fixture supply. An air chamber with a volume equivalent to one with the dimension listed above may also be used. Where an air chamber is installed in a riser, it shall be at least 24 inches in length and at least the same size as the riser.

2) Mechanical Devices. Where a mechanical device or water hammer arrestor is used, the manufacturer's specifications for location and installation shall be followed.

g) Excessive Static Water Pressure.

1) When water main pressure exceeds 80 p.s.i., a pressure reducing valve and a strainer with a by-pass relief valve shall be installed in the water service pipe near the entrance to the building to reduce the water pressure to 80 p.s.i. or lower, except where the water service pipe supplies water directly to a water pressure booster system, an elevated water tank, or to pumps provided in connection with a hydropneumatic or elevated water supply tank system. Sill cocks and outside hydrants may be left on full water main pressure.

2) When the water pressure exceeds 80 p.s.i. at any plumbing fixture, a pressure reducing valve, pressure gauge and a strainer with a by-pass relief valve shall be installed in a water supply pipe serving the fixture to reduce the water pressure at the fixture to 80 p.s.i. or lower.

h) Approval of Auxiliary Pressure Systems. Whenever in any building, structure, or premises receiving its potable water supply from the public water system, a pump or any other device for increasing the water pressure is to be installed, plans of such installation shall be approved by the Department prior to installation in accordance with Section 890.1940.

i) Variable Street Pressures. When the water main has a wide fluctuation in pressure, the water distribution system shall be designed for minimum pressure available at the main.

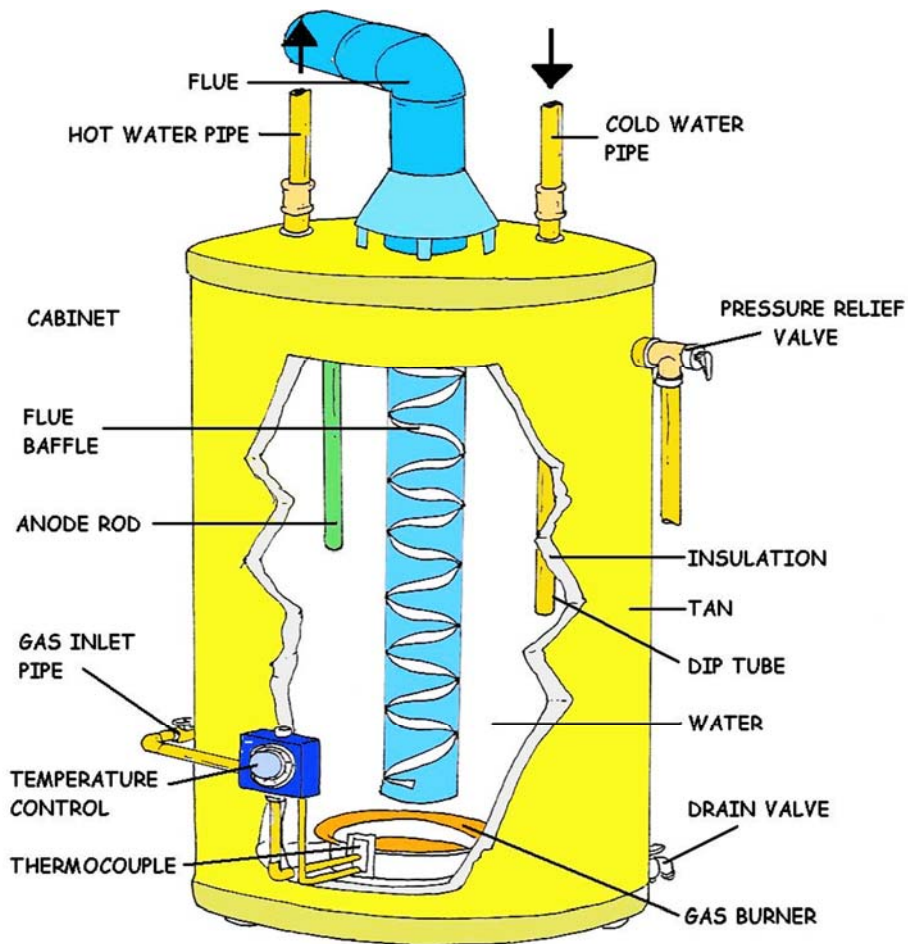

GAS WATER HEATER

Hot Water Supply and Distribution Question 52

- a) All water heaters shall comply with the requirements of Appendix A, Table A, (Approved Standards for Plumbing Appliances/Appurtenances/Devices), and ASHRAE 90 Standards. Hot water storage tanks shall meet construction requirements of ASME, AGA, or UL listed in Appendix A, Table A (Approved Standards for Plumbing Appliances/Appurtenances/Devices), as appropriate. Hot water supply boilers with heat input in excess of 200,000 BTU per hour, water temperature in excess of 200° F, or capacity in excess of 120 gallons must also comply with the requirements of the Boiler and Pressure Vessel Safety Rules and Regulations. Smaller water storage tanks that are not subject to ASME requirements shall be constructed of durable materials and constructed to withstand 150 p.s.i.
- 1) All equipment used for heating and storage of hot water shall bear the marking of an approved testing agency certifying that it has been tested and approved and listed as meeting the requirements of the applicable standard. Listing by Underwriters Laboratories, American Gas Association or National Board of Boiler and Pressure Vessel Inspectors, or the ASME Standard shall constitute evidence of conformance with these standards.
- 2) A solar-heated system shall use a double-walled heat exchanger which is exposed or vented to the atmosphere between the walls.
- 3) Heat exchangers may be of single wall construction if a non-toxic transfer fluid with no conditioning chemicals in the system is used, or if a pressure gradient monitor system is installed to isolate the heat exchanger from the potable water system. If pressure on the potable water side reaches a pressure less than 10 p.s.i. above the toxic transfer fluid pressure, an audible alarm shall be activated.
- 4) Heat exchangers using a toxic transfer fluid or having conditioning chemicals in the system shall be separated from the potable water by double wall construction. There shall be an air gap open to the atmosphere between the two walls. Where the boiler (heating chamber) operates in excess of 65 p.s.i., the requirements of subsection (a)(5) of this Section shall also apply.
- 5) No heat exchanger will be permitted on any boiler system operating in excess of 65 p.s.i., or high temperature hot water system operating in excess of 250°F, or any steam boiler operating with a pressure in excess of 50 p.s.i., unless:
- A) the heat exchanger is double-walled; and
- B) the heat exchanger has an air gap open to the atmosphere between the 2 walls; and
- C) the heat exchanger has a pressure gradient monitor system with a "fail-safe to off" switch installed to isolate the heat exchanger from the potable cold or hot water system. If pressure on the potable water side reaches a pressure less than 20 p.s.i. above the pressure of the transfer fluid or steam and a pressure reducing valve is installed on the inlet to the heat exchanger with a setting 20 p.s.i. lower than the potable water pressure at the

heat exchanger, an audible alarm shall be activated and the heat exchanger shall be automatically shut off until the alarm and heat exchanger can be reset manually.

6) Any boiler using toxic chemicals shall have a label with a minimum size of 5 inches X 5 inches attached to the boiler in a conspicuous place. The label shall read as follows:

WARNING

Chemicals and additives used to treat the boiler feed water in this boiler are not approved for potable water. The steam or hot water produced by this boiler is not potable. If the steam or hot water produced by this boiler is used to heat water, the water will not be considered potable if the steam and potable water are mixed.

7) Indirect, External, Submerged Coils. Indirect, external, tankless or submerged coils used in heating water shall be equipped with a thermostatic mixing valve or valves when not connected to a storage tank. A pressure relief valve shall be installed on the cold water inlet of the tank. A properly sized temperature and pressure relief valve, based upon the energy input rating of the coils, shall be installed on the tempered line with the temperature sensing element immersed in the tempered water line as close as possible to the mixing valve.

8) Direct Fired Instantaneous Heaters. (Storage tank of more than 64 fluid ounces.) Direct fired instantaneous water heaters shall be equipped with a thermostatic mixing valve or valves which conform to ASSE 1017-1999. A pressure relief valve shall be installed on or adjacent to the heater. A properly sized temperature and pressure relief valve, based upon the energy input rating of the heater, shall be installed on the tempered line with the temperature sensing element immersed in the tempered water line as close as possible to the mixing valve.

9) Water Heaters Used for Space Heating. Any water heater to be used for space heating, in addition to hot water supply, must conform to ANSI Z21.10.1a-1991, shall be constructed for continuous use, and the piping for space heating shall be conducted to a proper terminal heating device.

A) A thermostatic mixing valve, conforming to ASSE 1017-1999, shall be installed on the hot water line to the plumbing fixtures. (The mixing valve shall be set to prevent temperatures exceeding 120°F from reaching the plumbing fixtures.)

B) A single check valve shall be installed in the cold water line supplying the water heater. (This will prevent hot water backing up from the heating unit to the plumbing fixtures.)

C) A properly sized and approved expansion tank shall be located on the outlet side of the check valve in the water heater's cold water supply with no shut-off valve between the heater and expansion tank.

D) Valves (manual, automatic) supplying hot water to the heat transfer unit for space heating shall have a minimum of a 1 inch orifice. (This will prohibit potable water from standing in the heat transfer unit when not in use.) This does not prohibit full shut

off/isolation valves on either side of the pump within a heat transfer unit, as needed, to permit the servicing of the pump.

E) The water heater instructions shall have a statement specifying that piping and components connected to the water heater for the space heating application shall be suitable for use with potable water, and the water heater shall not exceed a developed length of more than 25 feet from the heating coil.

F) A statement specifying that toxic chemicals, such as those used for boiler treatment, shall not be introduced into the potable water used for space heating shall be included in the instructions. A label with the following words shall be firmly attached to any water heater used for space heating: "DO NOT INJECT TOXIC MATERIALS INTO THIS TANK."

G) A statement specifying that a water heater which will be used to supply potable water shall not be connected to any heating system or components previously used with a non-potable water heating appliance shall be included in the installation instructions.

H) Each water heater shall bear a statement on the rating plate as follows: "SUITABLE FOR POTABLE WATER HEATING AND SPACE HEATING."

10) Point-of-Use Instantaneous Water Heaters. Point-of-use instantaneous water heaters (high temperature, non-storage or storage of 64 fluid ounces or less, non-pressurized relative to atmosphere) shall meet the following requirements:

A) Units intended to deliver water temperatures exceeding 110°F, or with no mechanical or electrical temperature limiting device must have the faucet located at least 3 inches from the 110°F hot water or cold water faucet. All such faucet outlets shall have labels clearly and conspicuously indicating extremely hot water.

B) Units intended to deliver water temperatures 110°F or less shall have an internal burnout element or shall have a factory set thermostat that is not adjustable to higher than 110°F.

C) All pressurized point-of-use water heaters shall also have provisions as a part of the unit to provide temperature and pressure relief. Valves shall be set to relieve at 20°F above the intended water temperature and at 125 p.s.i. or at 15 p.s.i. below the pressure rating of the lowest rated part of the assembly, whichever is lower.

11) Steam Heat. All water heaters including storage heaters, instantaneous shell and tube heat exchangers, steam injection heaters and any other device using steam to heat water for potable use shall meet the following requirements:

A) All chemicals and additives used to treat the boiler feed water in a boiler supplying steam to heat potable water must be proper for use with potable water. Where such approved chemicals and additives are used with steam boilers generating at 15 p.s.i. or less, or are used with pressure reducing stations with pressure relief valves set at 15 p.s.i. or less downstream from the pressure reducing valves, single wall heat exchangers may be used.

B) Steam injection heaters must be supplied with steam from a generator or boiler which uses only United States Food and Drug Administration (FDA) approved additives or chemicals.

C) The following warning label with a minimum size of 5 inches X 5 inches shall be permanently attached to each steam injection heater:

"If the chemicals used to treat the feed water to provide steam for this steam injection water heater are not approved for potable water, the hot water from this heater shall not be considered potable. Therefore, each cross connection between the hot water and cold water connections to or from this heater must be provided with a device to prevent the backflow of hot water or steam condensate into the potable water supply."

D) The following warning label with a minimum size of 5 inches X 5 inches shall be permanently attached on the front of any boiler providing steam to direct injection steam hot water heaters:

"If the chemicals used to treat the boiler feed water in this boiler are not approved for potable water, the steam produced by this boiler cannot be considered potable. Therefore, if steam from this boiler is used to heat water, the water shall not be considered potable and any cross connections between the hot water produced and a potable water supply must be provided with a device to prevent the backflow of the non-potable hot water into the potable water supply."

b) Water Heaters – Food Service. Water heaters installed and utilized in food service establishments with dishwashing machines shall comply with National Sanitation Foundation (NSF) Standard.

c) With the exception of special water heaters used for space heating in addition to hot water supply, as provided in subsection (a)(9) of this Section, water that leaves the potable water system for heating, cooling, use in equipment or other similar uses shall not be returned to the potable water distribution system. When such water is discharged to the building drainage system it shall be discharged through a fixed air gap.

Safety Devices

a) All equipment used for heating water or storing hot water shall be provided, at the time of installation of such equipment, with an appropriate relief valve or valves to protect against excessive or unsafe temperature and/or pressure. This shall be achieved by installing either a pressure relief valve and a temperature relief valve or by installing a combination pressure-temperature relief valve.

b) Pressure and Temperature Relief Valves.

1) Pressure Relief Valves. Pressure relief valves shall have an ASME relief rating to meet the pressure conditions specified on the equipment served. They shall be installed in the cold water supply line to the heating equipment served, except where scale formation from hard water may be encountered, in which case they shall be installed in the hot water supply line from the heating equipment served. There shall not be a shut-off valve between

the pressure relief valve and the tank. Except where an alternate design is approved by the Department in writing pursuant to Section 890.140(a)(2) or 890.1940, the pressure relief valve must be set to open at a maximum of the working pressure rating of the water heater, but shall not exceed 150 p.s.i. Each pressure relief valve shall have a test lever.

2) Temperature Relief Valves. Temperature relief valves shall bear an American Gas Association (AGA) relief rating, expressed in British Thermal Units (BTU) of heat input per hour, for the equipment served. They shall be installed so that the temperature sensing element is immersed in the hottest water within the top 6 inches of the tank. The valve shall be set to open full when the stored water temperature is 210°F.

c) Combination Pressure-Temperature Relief Valves.

1) Combination pressure-temperature relief valves shall comply with the applicable requirements as listed in Appendix A, Table A (Approved Standards for Plumbing Appliances/Appurtenances/Devices) for individual pressure and individual temperature relief valves, and shall be installed so that the temperature sensing element is immersed in the hottest water within the top 6 inches of the tank and have a test lever.

2) A check valve or shut-off valve shall not be installed between any safety device and the hot water equipment, nor shall there be any shut-off valve in the discharge pipe from the relief valve.

3) Energy cut-off devices shall not be used in lieu of subsections (c)(1) and (2) of this Section and shall be of a design to properly serve the intended use of the plumbing appliance, appurtenance or device. Exception: Instantaneous cut-off devices are exempted or may be used.

d) Relief Discharge Outlet.

1) A relief discharge outlet shall be indirectly connected to waste. The discharge pipe from the relief valve shall not be located so as to create a safety hazard or to discharge in such a way as to cause damage to the building or its contents. The relief valve shall not discharge through a wall into the outside atmosphere or where there is a possibility of freezing.

2) No reduced coupling, valve or any other restriction shall be installed in the discharge line of any relief valve that would impede the flow of discharge. The discharge line shall be installed from the relief valve to within 6 inches of the floor or receptor and the end of such line shall not be threaded.

3) Any piping used for discharge from the relief valve shall be of metallic material and conform with the requirements of Appendix A, Table A (Approved Materials for Water Distribution Pipe) for potable water piping and shall drain continuously downward to the outlet.

4) The discharge piping shall discharge indirectly into a floor drain, hub drain, service sink, sump or a trapped and vented P-trap which is located in the same room as the water heater. (See Sections 890.1010 and 890.1050(a), (b) and (c).) The trap must have a deep

seal to protect against evaporation or shall be fed by means of a priming device designed and installed for that purpose. (The use of light grade oil in the trap will retard evaporation.)

- e) Pressure Marking – Hot Water Storage Tank. Hot water storage tanks shall be permanently marked in an accessible place with the maximum allowable working pressure.
- f) Vacuum Relief Valve. Where a hot water storage tank or water heater is located at an elevation above the fixture outlets in the hot water system, or if the storage tank or water heater is bottom fed, a vacuum relief valve as listed in Appendix A, Table A (Approved Standards for Plumbing Appliances/Appurtenances/Devices) shall be installed on the storage tank or heater.
- g) Multiple Temperature Hot Water Systems. Such systems shall be provided with thermostatic mixing valves to properly control the desired temperatures.

Glossary

ABS (Acrylonitrile butadiene styrene): Rigid black plastic pipe used only for drain lines.

ACCESS PANEL: An opening in the wall or ceiling near the fixture that allows access for servicing the plumbing/electrical system.

ADAPTOR: A fitting that unites different types of pipe together, e.g. ABS to cast iron pipe.

AIR BREAK: An air break is a physical separation which may be a low inlet into the indirect waste receptor from the fixture, or device that is indirectly connected. You will most likely find an air break on waste fixtures or on non-potable lines. You should never allow an air break on an ice machine.

AIR GAP SEPARATION: A physical separation space that is present between the discharge vessel and the receiving vessel, for an example, a kitchen faucet.

ALTERNATIVE DISINFECTANTS: Disinfectants - other than chlorination (halogens) - used to treat water, e.g. ozone, ultraviolet radiation, chlorine dioxide, and chloramine. There is limited experience and scientific knowledge about the by-products and risks associated with the use of alternatives.

AMMONIA: A chemical made with Nitrogen and Hydrogen and used with chlorine to disinfect water.

AQUIFER: An underground geologic formation capable of storing significant amounts of water.

BACKFLOW PREVENTION: To stop or prevent the occurrence of the unnatural act of reversing the normal direction of the flow of liquids, gases, or solid substances back into the public potable (drinking) water supply. See Cross-connection control.

BACKFLOW: To reverse the natural and normal directional flow of liquids, gases, or solid substances back in to the public potable (drinking) water supply. This is normally an undesirable effect.

BACKSIPHONAGE: A liquid substance that is carried over a higher point. It is the method by which the liquid substance may be forced by excess pressure over or into a higher point.

BENCHING: A method of protecting employees from cave-ins by excavating the sides of an excavation to form one or a series of horizontal levels or steps, usually with vertical or near vertical surfaces between levels.

BREAK POINT CHLORINATION: The process of chlorinating the water with significant quantities of chlorine to oxidize all contaminants and organic wastes and leave all remaining chlorine as free chlorine.

BROMINE: Chemical disinfectant (HALOGEN) that kills bacteria and algae.

BUFFER: Chemical that resists pH change, e.g. sodium bicarbonate.

CALCIUM HARDNESS: A measure of the calcium salts dissolved in water.

CAUSTIC SODA: Also known as sodium hydroxide and is used to raise pH.

CAVE-IN: The separation of a mass of soil or rock material from the side of an excavation, or the loss of soil from under a trench shield or support system, and its sudden movement into the excavation, either by failing or sliding, in sufficient quantity so that it could entrap, bury, or otherwise injure and immobilize a person.

CENTRIFUGAL PUMP: A pump consisting of an impeller fixed on a rotating shaft and enclosed in a casing, having an inlet and a discharge connection. The rotating impeller creates pressure in the liquid by the velocity derived from centrifugal force.

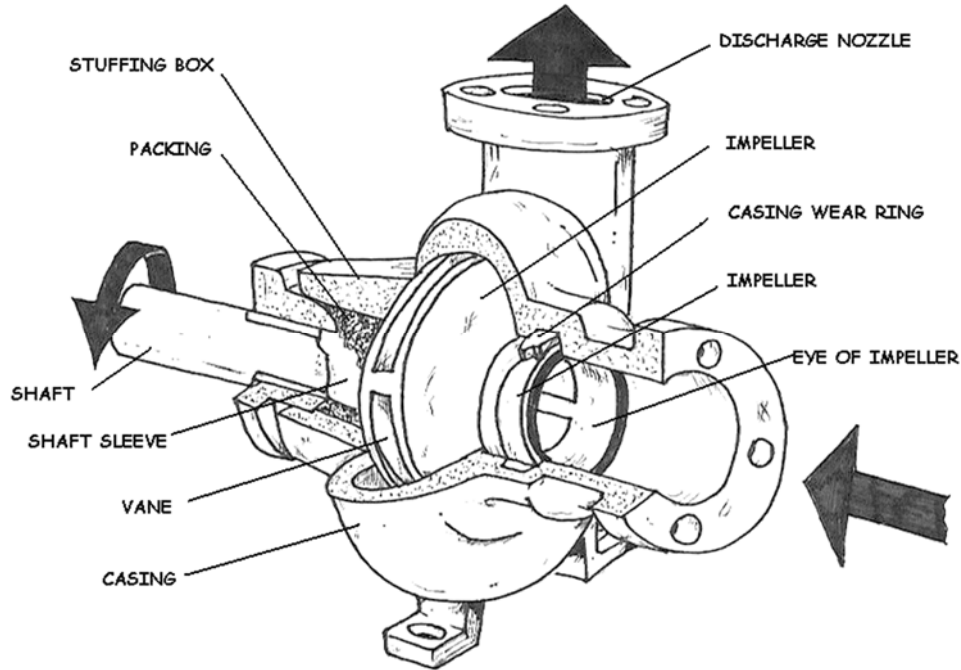

CHLORAMINATION: Treating drinking water by applying chlorine before or after ammonia. This creates a persistent disinfectant residual.

CHLORINATION: The process in water treatment of adding chlorine (gas or solid hypochlorite) for purposes of disinfection.

CHLORAMINES: A group of chlorine ammonia compounds formed when chlorine combines with organic wastes in the water. Chloramines are not effective as disinfectants and are responsible for eye and skin irritation as well as strong chlorine odors (also known as Combined Chlorine).

CHLORINE: A chemical which destroys small organisms in water. Chemical disinfectant that kills bacteria and algae.

CHLORINE DEMAND: Amount of chlorine required to react on various water impurities before a residual is obtained. Also, means the amount of chlorine required to produce a free chlorine residual of 0.1 mg/l after a contact time of fifteen minutes as measured by Iodometric method of a sample at a temperature of twenty degrees in conformance with Standard methods.

CHLORINE, FREE: Chlorine available to kill bacteria or algae. The amount of chlorine available for sanitization after the chlorine demand has been met. Also known as chlorine residual.

CLEANOUT: A plug in a trap or drain pipe that provides access for the purpose of clearing an obstruction.

CLOSET AUGER: A flexible rod with a curved end used to access the toilet's built-in trap and remove clogs.

CLOSET BEND: A curved fitting that connects the closet flange to the toilet drain.

CLOSET FLANGE: An anchoring ring secured to the floor. The base of the toilet is secured to this ring with bolts.

COLIFORM: A group of bacteria commonly found in the environment. They are an indicator of potential contamination of water. Adequate and appropriate disinfection effectively destroys coliform bacteria.

COMBINED CHLORINE: The reaction product of chlorine with ammonia or other pollutants, also known as chloramines.

COMPETENT PERSON: One who is capable of identifying existing and predictable hazards in the surroundings or working conditions, which are unsanitary, hazardous, or dangerous to employees, and who has authorization to take prompt corrective measures to eliminate them.

CONTAMINANT: Any natural or man-made physical, chemical, biological, or radiological substance or matter in water, which is at a level that may have an adverse effect on public health, and which is known or anticipated to occur in public water systems.

CONTAMINATION: To make something bad. To pollute or infect something. To reduce the quality of the potable (drinking) water and create an actual hazard to the water supply by poisoning or through spread of diseases.

CORROSION: The removal of metal from copper, other metal surfaces and concrete surfaces in a destructive manner. Corrosion is caused by improperly balanced water or excessive water velocity through piping or heat exchangers.

COUPLING: A fitting that joins two pieces of pipe.

CPVC (Chlorinated Polyvinyl Chloride): Rigid plastic pipe used in water supply systems, where code permits.

CROSS-CONTAMINATION: The mixing of two unlike qualities of water. For example, the mixing of good water with a polluting substance like a chemical.

CRYPTOSPORIDIUM: A disease-causing parasite, resistant to chlorine disinfection. It may be found in fecal matter or contaminated drinking water.

DISINFECT: To kill and inhibit growth of harmful bacterial and viruses in drinking water.

DISINFECTION BY-PRODUCTS (DBPs): The products created due to the reaction of chlorine with organic materials (e.g. leaves, soil) present in raw water during the water treatment process. The EPA has determined that these DBPs can cause cancer.

DISINFECTION: The treatment of water to inactivate, destroy, and/or remove pathogenic bacteria, viruses, protozoa, and other parasites.

DWV: Abbreviation for drain, waste and vent.

E. COLI, Escherichia coli: is a bacterium commonly found in the human intestine. For water quality analyses purposes, it is considered an indicator organism. These are considered evidence of water contamination. Indicator organisms may be accompanied by pathogens, but do not necessarily cause disease themselves.

ELBOW: A pipe fitting with two openings that changes the direction of the line. Also called an ell. It comes in a variety of angles, from 22 1/2° to 90°.

ELEVATION HEAD: The energy possessed per unit weight of a fluid because of its elevation. 1 foot of water will produce .433 pounds of pressure head.

ENERGY: The ability to do work. Energy can exist in one of several forms, such as heat, light, mechanical, electrical, or chemical. Energy can be transferred to different forms. It also can exist in one of two states, either potential or kinetic.

ENHANCED COAGULATION: The process of joining together particles in water to help remove organic matter.

ENTEROVIRUS: A virus whose presence may indicate contaminated water; a virus which may infect the gastrointestinal tract of humans.

FALL-FLOW: The proper slope or pitch of a pipe for adequate drainage.

FECAL COLIFORM: A group of bacteria that may indicate the presence of human or animal fecal matter in water.

FILTRATION: A series of processes that physically remove particles from water.

FINISHED WATER: Treated drinking water that meets state and federal drinking water regulations.

FIXTURE: In plumbing, the devices that provide a supply of water and/or its disposal, e.g. sinks, tubs, toilets.

FLOCCULATION: The process of bringing together destabilized or coagulated particles to form larger masses which can be settled and/or filtered out of the water being treated.

FLOOD RIM: The point of an object where the water would run over the edge of something and begin to cause a flood. See Air Break.

FLUX: The paste that is used in soldering metal joints. Flux aids the process by preventing oxidation of the joint.

GIARDIA LAMBLIA: A pathogenic parasite which may be found in contaminated water.

HAZARDOUS ATMOSPHERE: An atmosphere which by reason of being explosive, flammable, poisonous, corrosive, oxidizing, irritating, oxygen deficient, toxic, or otherwise harmful, may cause death, illness, or injury.

HEAD: The measure of the pressure of water, expressed in feet, of height of water. 1 psi = 2.41 feet of water. There are various types of heads of water depending upon what is being measured; for example, Static (water at rest) and Residual (water at flow conditions).

HEADWORKS: The facility at the "head" of the water source where water is first treated and routed into the distribution system.

HETEROTROPHIC PLATE COUNT BACTERIA: A broad group of bacteria including non-pathogens, pathogens, and opportunistic pathogens; they may be an indicator of poor general biological quality of drinking water. Often referred to as HPC.

I.D.: Abbreviation for inside diameter. All pipes are sized according to their inside diameter.

INFECTIOUS PATHOGENS/ MICROBES/GERMS: Disease-producing bacteria, viruses and other microorganisms.

IRRIGATION: Water that is especially furnished to help provide and sustain the life of growing plants. It comes from ditches, and it is sometimes treated with herbicides and pesticides to prevent the growth of weeds and the development of bugs in a lawn or garden.

KINETIC ENERGY: The ability of an object to do work by virtue of its motion. The energy terms that are used to describe the operation of a pump are pressure and head.

LANGELIER INDEX: A mathematically derived factor obtained from the values of calcium hardness, total alkalinity, and pH at a given temperature. A Langelier index of zero indicates perfect water balance (i.e., neither corroding nor scaling).

MAXIMUM CONTAMINANT LEVELS (MCLs): The maximum allowable level of a contaminant that federal or state regulations allow in a public water system. If the MCL is exceeded, the water system must treat the water so that it meets the MCL. Or provide adequate backflow protection.

MECHANICAL SEAL: A mechanical device used to control leakage from the stuffing box of a pump. Usually made of two flat surfaces, one of which rotates on the shaft. The two flat surfaces are of such tolerances as to prevent the passage of water between them.

Mg/L: milligrams per liter

MICROBE, MICROBIAL: Any minute, simple, single-celled form of life, especially one that causes disease.

MICROBIAL CONTAMINANTS: Microscopic organisms present in untreated water that can cause waterborne diseases.

mL: milliliter.

NON-CHLORINE SHOCK: Oxygen based shocking compound. Non Chlorine shock is fast dissolving so it allows swimming just 15 minutes after use.

NTU (nephelometric turbidity unit): A measure of the clarity of water.

O.D.: Abbreviation for outside diameter.

OXIDIZING: The process of breaking down organic wastes into simpler elemental forms or by products. Also used to separate combined chlorine and convert it into free chlorine.

PATHOGENS: disease-causing pathogens; waterborne pathogens. A pathogen is a bacterium, virus or parasite that causes or is capable of causing disease. Pathogens may contaminate water and cause waterborne disease.

pCi/L: picocuries per liter. A curie is the amount of radiation released by a set amount of a certain compound. A picocurie is one quadrillionth of a curie.

PIPELINE APPURTENANCE: Pressure reducers, bends, valves, regulators (which are a type of valve), etc.

POTABLE: Good water which is safe for drinking or cooking purposes. Non-Potable: A liquid or water that is not approved for drinking.

PB (Polybutylene): Flexible plastic tubing used in water supply systems where allowed by code.

pH: A measure of the acidity of water. The pH scale runs from 0 to 14 with 7 being the mid-point or neutral. A pH of less than 7 is on the acid side of the scale with 0 as the point of greatest acid activity. A pH of more than 7 is on the basic (alkaline) side of the scale with 14 as the point of greatest basic activity. pH (Power of Hydroxyl Ion Activity).

pH OF SATURATION: The ideal pH for perfect water balance in relation to a particular total alkalinity level and a particular calcium hardness level, at a particular temperature. The pH where the Langelier Index equals zero.

PHENOL RED: Chemical reagent used for testing pH in the range of 6.8 - 8.4.

PLUMBER'S PUTTY: A pliable, popular putty used to seal joints between drain pieces and fixture surfaces.

POLLUTION: To make something unclean or impure. Some states will have a definition of pollution that relates to non-health related water problems, like taste and odors. See Contaminated.

POTENTIAL ENERGY: The energy that a body has by virtue of its position or state enabling it to do work.

ppm: Abbreviation for parts per million.

PRE-CHLORINATION: The addition of chlorine to the water prior to any other plant treatment processes.

PRESSURE HEAD: The height to which liquid can be raised by a given pressure.

PROGRAMMATIC CONSERVATION: Conservation that results from public education efforts that influence consumer behavior. Examples include turning off the water when brushing your teeth, washing only full loads of laundry, fixing leaks, etc.

PVC (Polyvinyl Chloride): A rigid white or cream colored plastic pipe used in non-pressure systems, such as waste and vent systems.

RAW WATER: Water that has not been treated in any way; it is generally considered to be unsafe to drink. Sometimes referred to as Auxiliary Water.

REDUCER: A fitting that connects pipes of different sizes.

RESERVOIR: An impoundment used to store water.

RESIDUAL DISINFECTION/ PROTECTION: A required level of disinfectant that remains in treated water to ensure disinfection protection and prevent recontamination throughout the distribution system (i.e., pipes).

RISER: A vertical assembly of fittings and pipes that distributes water upward.

ROUGH-IN: The portion of a plumbing installation that includes running the water supply lines and drain, waste & vent lines to the proposed location of each fixture.

RUN: A complete or secondary section(s) of pipe that extends from supply to fixture or drain to stack.

SANITARY FITTING: Fitting that joins the assorted pipes in a drain, waste and vent system; designed to allow solid material to pass through without clogging.

SANITIZER: A chemical which disinfects (kills bacteria), kills algae and oxidizes organic matter.

SCALE: Crust of calcium carbonate, the result of unbalanced pool water. Hard, insoluble mineral deposits (usually calcium bicarbonate) which form on pool and spa surfaces and clog filters, heaters and pumps. Scale is caused by high calcium hardness and/or high pH. You will often find major scale deposits inside a backflow prevention assembly.

SEDIMENTATION: The process of suspended solid particles settling out (going to the bottom of the vessel) in water. The use of a strainer before the backflow assembly can help remove some of the coarse sedimentation.

SLOPING: A method of protecting workers from cave-ins by excavating to form sides of an excavation that are inclined away from the excavation to prevent cave-ins. The angle of incline required to prevent a cave-in varies with differences such as soil type, length of exposure, and application of surcharge loads.

SOIL STACK: Largest vertical drain line to which all branch waste lines connect; carries waste to the sewer line.

SOLDER: A fusible alloy used to join metallic parts. Solder for potable water pipes shall be lead-free.

SHOCK: Also known as superchlorination or break-point chlorination. Ridding a pool of organic waste through oxidization by the addition of significant quantities of a halogen.

SOLDER: A metal alloy that is melted to join or mend metal surfaces; also, the act of melting solder into the joint.

STANDPIPE: A water tank that is taller than it is wide.

STOP VALVE: A valve that controls the flow of water to an individual fixture, allowing water supply to be stopped to one fixture without affecting the water supply to other fixtures.

STUFFING BOX: That portion of the pump which houses the packing or mechanical seal.

SUBMERGED: To cover with water or liquid substance.

SUPERCHLORINATION: Application of large dosages of chlorine to destroy buildup of undesirable compounds in water.

SURFACE WATER: Water which is open to the atmosphere and subject to surface runoff; generally, lakes, streams, rivers.

TCE, trichloroethylene: A solvent and degreaser used for many purposes; for example, dry cleaning is a common groundwater contaminant.

TITRATION: method of testing by adding a reagent of known strength to a water sample until a specific color change indicates the completion of the reaction.

TEE: A T-shaped fitting with three openings used to create branch lines.

TOTAL ALKALINITY: A measure of the acid-neutralizing capacity of water which indicates its buffering ability, i.e. measure of its resistance to a change in pH. Generally, the higher the total alkalinity, the greater the resistance to pH change.

TOTAL DISSOLVED SOLIDS (TDS) : The accumulated total of all solids that might be dissolved in water.

TRAP: Curved section of a fixture drain line; designed to hold water, thus preventing sewer gases from entering the house.

TREATED WATER: Disinfected and/or filtered water served to water system customers. It must meet or surpass all drinking water standards to be considered safe to drink.

TRENCH: A narrow excavation below the surface of the ground, less than 15 feet wide, with a depth no greater than the width.

TRihalOMETHANES(THM): Four separate compounds including chloroform, dichlorobromomethane, dibromochloromethane, and bromoform. The most common class of disinfection by-products created when chemical disinfectants react with organic matter in water during the disinfection process. See Disinfectant Byproducts.

TURBIDITY: A measure of the cloudiness of water caused by suspended particles.

UNDERMINING: Undermining can be caused by such things as leaking, leaching, caving or over-digging. Undermined walls can be very dangerous.

UNION: Three-piece fitting that joins two sections of pipe, but allows them to be disconnected without cutting the pipe. Used primarily with steel pipes, but never in a DWV system.

VALVE: A device that opens and closes to regulate the flow of liquids. Faucet, hose bib, and Ball are examples of valves.

VANE: That portion of an impeller which throws the water toward the volute.

VELOCITY HEAD: The vertical distance a liquid must fall to acquire the velocity with which it flows through the piping system. For a given quantity of flow, the velocity head will vary indirectly as the pipe diameter varies.

VENT STACK: The upper portion of the soil stack above the topmost fixture through which gases and odors escape.

VENTURI: If water flows through a pipeline at a high velocity, the pressure in the pipeline is reduced. Velocities can be increased to a point that a partial vacuum is created.

VIBRATION: A force that is present on construction sites and must be considered. The vibrations caused by backhoes, dump trucks, compactors and traffic on job sites can be substantial.

VOLUTE: The spiral-shaped casing surrounding a pump impeller that collects the liquid discharge by the impeller.

WATER WORKS: All of the pipes, pumps, reservoirs, dams and buildings that make up a water system.

WATERBORNE DISEASES: A disease, caused by a virus, bacterium, protozoan, or other microorganism, capable of being transmitted by water (e.g., typhoid fever, cholera, amoebic dysentery, gastroenteritis).

WATERSHED: An area which drains all of its water to a particular water course or body of water.

WATER PURVEYOR: The individual or organization responsible to help provide, supply, and furnish quality water to a community.

WYE: A Y-shaped fitting with three openings used to create branch lines.

References

Several Photographs and Reference were provided by
GA Industries, Inc.
WWW. Gaindustries.com
Telephone (724) 776-1020
Fax (724) 776-1254
9025 Marshall Road
Cranberry Township, PA 16066 USA

CLA-VAL
P.O.Box 1325
Newport Beach, CA 92659-0325
Phone: (949) 722-4800 • 1-800-942-6326
Fax: (949) 548-5441
www.cla-val.com
E-mail: claval@cla-val.com
US Regional Offices

WESTERN REGION:
Phone: (951) 687-9145
1-800-247-9090
Fax: (951) 687-9954
E-mail: lvanderk@cla-val.com

SOUTHERN REGION:
Phone: (281) 759-9590
1-800-336-7171
Fax: (281) 759-8938
E-mail: blindsey@cla-val.com

NORTHERN REGION:
Phone: (847) 697-1413
1-800-238-7070
Fax: (847) 697-5549
E-mail: djurs@cla-val.com

EASTERN REGION:
Phone: (703) 721-1923
1-800-451-3030
Fax: (703) 721-1927
E-mail: bmoore@cla-val.com

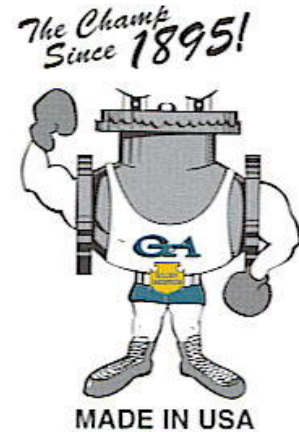

Math Conversion Factors

1 PSI = 2.31 Feet of Water
 1 Foot of Water = .433 PSI
 1.13 Feet of Water = 1 Inch of Mercury
 454 Grams = 1 Pound
 2.54 CM =Inch
 1 Gallon of Water = 8.34 Pounds
 1 mg/L = 1 PPM
 17.1 mg/L = 1 Grain/Gallon
 1% = 10,000 mg/L
 694 Gallons per Minute = MGD
 1.55 Cubic Feet per Second = 1 MGD
 60 Seconds = 1 Minute
 1440 Minutes = 1 Day
 .746 kW = 1 Horsepower

LENGTH

12 Inches = 1 Foot
 3 Feet = 1 Yard
 5280 Feet = 1 Mile

AREA

144 Square Inches = 1 Square Foot
 43,560 Square Feet =1 Acre

VOLUME

1000 Milliliters = 1 Liter
 3.785 Liters = 1 Gallon
 231 Cubic Inches = 1 Gallon
 7.48 Gallons = 1 Cubic Foot of water
 62.38 Pounds = 1 Cubic Foot of water

Dimensions

SQUARE: Area (sq.ft.) = Length X Width
 Volume (cu.ft.) = Length (ft) X Width (ft) X Height (ft)

CIRCLE: Area (sq.ft.) = 3.14 X Radius (ft) X Radius (ft)

CYLINDER: Volume (Cu. ft) = 3.14 X Radius (ft) X Radius (ft) X Depth (ft)

PIPE VOLUME: .785 X Diameter ² X Length = ? To obtain gallons multiply by 7.48

SPHERE: $\frac{(3.14) (\text{Diameter})^3}{(6)}$ Circumference = 3.14 X Diameter

General Conversions

Flowrate

Multiply	→	to get
to get	←	Divide
cc/min	1	mL/min
cfm (ft ³ /min)	28.31	L/min
cfm (ft ³ /min)	1.699	m ³ /hr
cfh (ft ³ /hr)	472	mL/min
cfh (ft ³ /hr)	0.125	GPM
GPH	63.1	mL/min
GPH	0.134	cfh
GPM	0.227	m ³ /hr
GPM	3.785	L/min
oz/min	29.57	mL/min

POUNDS PER DAY= Concentration (mg/L) X Flow (MG) X 8.34

AKA Solids Applied Formula = Flow X Dose X 8.34

PERCENT EFFICIENCY = $\frac{\text{In} - \text{Out}}{\text{In}} \times 100$

TEMPERATURE: $^{\circ}\text{F} = (^{\circ}\text{C} \times 9/5) + 32$ $9/5 = 1.8$
 $^{\circ}\text{C} = (^{\circ}\text{F} - 32) \times 5/9$ $5/9 = .555$

CONCENTRATION: Conc. (A) X Volume (A) = Conc. (B) X Volume (B)

FLOW RATE (Q): $Q = A \times V$ (**Q**uantity = **A**rea X **V**elocity)

FLOW RATE (gpm): Flow Rate (gpm) = $\frac{2.83 (\text{Diameter, in})^2 (\text{Distance, in})}{\text{Height, in}}$

% SLOPE = $\frac{\text{Rise (feet)}}{\text{Run (feet)}} \times 100$

ACTUAL LEAKAGE = $\frac{\text{Leak Rate (GPD)}}{\text{Length (mi.)} \times \text{Diameter (in)}}$

VELOCITY = $\frac{\text{Distance (ft)}}{\text{Time (Sec)}}$

N = Manning's Coefficient of Roughness

R = Hydraulic Radius (ft.)

S = Slope of Sewer (ft/ft.)

HYDRAULIC RADIUS (ft) = $\frac{\text{Cross Sectional Area of Flow (ft)}}{\text{Wetted pipe Perimeter (ft)}}$

WATER HORSEPOWER = $\frac{\text{Flow (gpm)} \times \text{Head (ft)}}{3960}$

BRAKE HORSEPOWER = $\frac{\text{Flow (gpm)} \times \text{Head (ft)}}{3960 \times \text{Pump Efficiency}}$

MOTOR HORSEPOWER = $\frac{\text{Flow (gpm)} \times \text{Head (ft)}}{3960 \times \text{Pump Eff.} \times \text{Motor Eff.}}$

MEAN OR AVERAGE = $\frac{\text{Sum of the Values}}{\text{Number of Values}}$

TOTAL HEAD (ft) = Suction Lift (ft) X Discharge Head (ft)

SURFACE LOADING RATE = $\frac{\text{Flow Rate (gpm)}}{(\text{gal/min/sq.ft}) \times \text{Surface Area (sq. ft)}}$

MIXTURE STRENGTH (%) = $\frac{(\text{Volume 1, gal}) (\text{Strength 1, \%}) + (\text{Volume 2, gal}) (\text{Strength 2, \%})}{(\text{Volume 1, gal}) + (\text{Volume 2, gal})}$

INJURY FREQUENCY RATE = $\frac{(\text{Number of Injuries}) \times 1,000,000}{\text{Number of hours worked per year}}$

$$\text{SLOPE} = \frac{\text{Rise (ft)}}{\text{Run (ft)}}$$

$$\text{SLOPE (\%)} = \frac{\text{Rise (ft)} \times 100}{\text{Run (ft)}}$$

POPULATION EQUIVALENT (PE):

1 PE = .17 Pounds of BOD per Day

1 PE = .20 Pounds of Solids per Day

1 PE = 100 Gallons per Day

$$\text{LEAKAGE (GPD/inch)} = \frac{\text{Leakage of Water per Day (GPD)}}{\text{Sewer Diameter (inch)}}$$

$$\text{CHLORINE DEMAND (mg/L)} = \text{Chlorine Dose (mg/L)} - \text{Chlorine Residual (mg/L)}$$

MANNING'S EQUATION

τQ = Allowable time for decrease in pressure from 3.5 PSI to 2.5 PSI

τq = As below

$$\tau Q = (0.022) (d_1^2 L_1) / Q \quad \tau q = \frac{[0.085] [(d_1^2 L_1) / (d_1 L_1)]}{q}$$

Q = 2.0 cfm air loss

θ = .0030 cfm air loss per square foot of internal pipe surface

δ = Pipe diameter (inches)

L = Pipe Length (feet)

$$V = \frac{1.486 R^{2/3} S^{1/2}}{v}$$

V = Velocity (ft./sec.)

v = Pipe Roughness

R = Hydraulic Radius (ft)

S = Slope (ft/ft)

$$\text{HYDRAULIC RADIUS (ft)} = \frac{\text{Flow Area (ft. }^2\text{)}}{\text{Wetted Perimeter (ft.)}}$$

$$\text{WIDTH OF TRENCH (ft)} = \text{Base (ft)} + (2 \text{ Sides}) \times \frac{\text{Depth (ft }^2\text{)}}{\text{Slope}}$$

REFERENCES

- Benenson, Abram S., editor. 1990. *Control of Communicable Diseases in Man*. 15th ed. Baltimore: Victor Graphics, Inc.
- Bick, H. 1972. Ciliated protozoa. An illustrated guide to the species used as biological indicators in freshwater biology. World Health Organization, Geneva. 198 pp.
- Born, Stephen M., Douglas A. Yanggen, and Alexander Zaporozec. *A Guide to Groundwater Quality Planning and Management for Local Governments*. Wisconsin Geological and Natural History Survey, Madison, WI, 1987.
- Cairns, J., and J.A. Ruthven. 1972. A test of the cosmopolitan distribution of fresh-water protozoans. *Hydrobiologia* 39:405-427.
- Cairns, J., and W.H. Yongue. 1977. Factors affecting the number of species of freshwater protozoan communities. Pages 257-303 in J. Cairns, ed. *Aquatic microbial communities*. Garland, New York.
- Cairns, J., G.R. Lanza, and B.C. Parker. 1972. Pollution related structural and functional changes in aquatic communities with emphasis on freshwater algae and protozoa. *Proceedings of the National Academy of Sciences* 124:79-127.
- Concern, Inc. *Groundwater: A Community Action Guide*. Washington, D.C., 1989.
- Cross, Brad L and Jack Schulze. *City of Hurst (A Public Water Supply Protection Strategy)*. Texas Water Commission, Austin, TX, 1989.
- Curds, C.R. 1992. *Protozoa and the water industry*. Cambridge University Press, MA. 122 pp.
- Curtis, Christopher and Teri Anderson. *A Guidebook for Organizing a Community Collection Event: Household Hazardous Waste*. Pioneer Valley Planning Commission and Western Massachusetts Coalition for Safe Waste Management, West Springfield, MA, 1984.
- Curtis, Christopher, Christopher Walsh, and Michael Przybyla. *The Road Salt Management Handbook: Introducing a Reliable Strategy to Safeguard People & Water Resources*. Pioneer Valley Planning Commission, West Springfield, MA, 1986.
- Fenchel, T. 1974. Intrinsic rate increase: the relationship with body size. *Oecologia* 14:317-326.
- Fenchel, T., T. Perry, and A. Thane. 1977. Anaerobiosis and symbiosis with bacteria in free-living ciliates. *Journal of Protozoology* 24:154-163.
- Foissner, W. 1987. Soil protozoa: fundamental problems, ecological significance, adaptations in ciliates and testaceans, bioindicators, and guide to the literature. *Progress in Protistology* 2:69-212.
- Foissner, W. 1988. Taxonomic and nomenclatural revision of Stádecek's list of ciliates (Protozoa: Ciliophora) as indicators of water quality. *Hydrobiologia* 166:1-64.
- Foster, Laurence, M.D. 1985. "Waterborne Disease - It's Our Job to Prevent It". PIPELINE newsletter, Oregon Health Division, Drinking Water Program, Portland, Oregon 1(4): 1-3.
- Foster, Laurence, M.D. 1990. "Waterborne Disease," *Methods for the Investigation and Prevention of Waterborne Disease Outbreaks*. Ed. Gunther F. Craun. Cincinnati: U.S. Environmental Protection Agency.
- Giese, A.C. 1973. *Blepharisma*. Stanford University Press, CA. 366 pp.
- Gordon, Wendy. *A Citizen's Handbook on Groundwater Protection*. Natural Resources Defense Council, New York, NY 1984.
- Harrison, Ellen Z. and Mary Ann Dickinson. *Protecting Connecticut's Groundwater: A Guide to Groundwater Protection for Local Officials*. Connecticut Department of Environmental Protection, Hartford, CT, 1984.

Hrezo, Margaret and Pat Nickinson. *Protecting Virginia's Groundwater A Handbook for Local Government Officials*. Virginia Polytechnic Institute and State University, Blacksburg, VA, 1986.

Jaffe, Martin and Frank Dinovo. *Local Groundwater Protection*. American Planning Association, Chicago, IL, 1987.

Kreier, J.P., and J.R. Baker. 1987. Parasitic protozoa. Allen and Unwin, Boston, MA. 241 pp.

Laybourn, J., and B.J. Finlay. 1976. Respiratory energy losses related to cell weight and temperature in ciliated protozoa. *Oecologia* 44:165-174.

Lee, C.C., and T. Fenchel. 1972. Studies on ciliates associated with sea ice from Antarctica. II. Temperature responses and tolerances in ciliates from Antarctica, temperate and tropical habitats. *Archive für Protistenkunde* 114:237-244.

Loomis, George and Yael Calhoun. "Natural Resource Facts: Maintaining Your Septic System." University of Rhode Island, Providence, RI, 1988.

Macozzi, Maureen. *Groundwater- Protecting Wisconsin's Buried Treasure*. Wisconsin Department of Natural Resources, Madison, WI, 1989.

Maine Association of Conservation Commissions. *Ground Water... Maine's Hidden Resource*. Hallowell, ME, 1985.

Massachusetts Audubon Society "Local Authority for Groundwater Protection." Groundwater Information Flyer #4. Lincoln, MA, 1984.

Massachusetts Audubon Society. "Groundwater and Contamination: From the Watershed into the Well." Groundwater Information Flyer # 2. Lincoln, MA, 1984.

Massachusetts Audubon Society. "Mapping Aquifers and Recharge Areas." Groundwater Information Flyer # 3. Lincoln, MA, 1984.

Massachusetts Audubon Society. "Road Salt and Groundwater Protection." Groundwater Information Flyer # 9. Lincoln, MA, 1987.

McCann, Alyson and Thomas P Husband. "Natural Resources Facts: Household Hazardous Waste." University of Rhode Island, Providence, RI; 1988.

Miller, David W. *Groundwater Contamination: A Special Report*. Geraghty & Miller, Inc., Syosset, NY 1982.

Montagnes, D.J.S., D.H. Lynn, J.C. Roff, and W.D. Taylor. 1988. The annual cycle of heterotrophic planktonic ciliates in the waters surrounding the Isles of Shoals, Gulf of Maine: an assessment of their trophic role. *Marine Biology* 99:21-30.

Mullikin, Elizabeth B. *An Ounce of Prevention: A Ground Water Protection Handbook for Local Officials*. Vermont Departments of Water Resources and Environmental Engineering, Health, and Agriculture, Montpelier, VT, 1984.

Murphy, Jim. "Groundwater and Your Town: What Your Town Can Do Right Now." Connecticut Department of Environmental Protection, Hartford, CT.

National Research Council. *Ground Water Quality Protection: State and Local Strategies*. National Academy Press, Washington, D.C., 1986.

New England Interstate Water Pollution Control Commission. "Groundwater: Out of Sight Not Out of Danger." Boston, MA, 1989.

Niederlehner, B.R., K.W. Pontasch, J.R. Pratt, and J. Cairns. 1990. Field evaluation of predictions of environmental effects from multispecies microcosm toxicity test. *Archives of Environmental Contamination and Toxicology* 19:62-71.

Noake, Kimberly D. Guide to *Contamination Sources for Wellhead Protection*. Draft. Massachusetts Department of Environmental Quality Engineering, Boston, MA, 1988.

Office of Drinking Water. *A Local Planning Process for Groundwater Protection*. U.S. EPA, Washington, D.C., 1989.

Office of Ground-Water Protection. *Guidelines for Delineation of Wellhead Protection Areas*. U.S. EPA, Washington, D.C., 1987.

Office of Ground-Water Protection. *Survey of State Ground Water Quality Protection Legislation Enacted From 1985 Through 1987*. U.S. EPA, Washington, D.C., 1988.

Office of Ground-Water Protection. *Wellhead Protection Programs. - Tools for Local Governments*. U.S. EPA, Washington, D.C., 1989.

Office of Ground-Water Protection. *Wellhead Protection: A Decision-Makers' Guide*. U.S. EPA, Washington, D.C., 1987

Office of Pesticides and Toxic Substances. *Citizen's Guide to Pesticides*. U.S. EPA, Washington, D.C., 1989.

Office of Underground Storage Tanks. *Musts for USGS. - A Summary of the New Regulations for Underground Storage Tank Systems*. U.S. EPA, Washington, D.C., 1988.

Ohio Environmental Protection Agency. *Ground Water*. Columbus, OH.

Redlich, Susan. *Summary of Municipal Actions for Groundwater Protection in the New England/New York Region*. New England Interstate Water Pollution Control Commission, Boston, MA, 1988.

Southern Arizona Water Resources Association. "Water Warnings: Our Drinking Water.... It Takes Everyone to Keep It Clean." Tucson, AZ.

Sponenberg, Torsten D. and Jacob H. Kahn. *A Groundwater Primer for Virginians*. Virginia Polytechnic Institute and State University, Blacksburg, VA, 1984.

Taylor, W., and R. Sanders. 1991. Protozoa. Pages 37-93 in J.H. Thorp and A.P. Covich, eds. *Ecology and classification of North American freshwater invertebrates*. Academic Press, New York.

Texas Water Commission. "On Dangerous Ground: The Problem of Abandoned Wells in Texas." Austin, TX, 1989.

Texas Water Commission. *The Underground Subject: An Introduction to Ground Water Issues in Texas*. Austin, TX, 1989.

U.S. Environmental Protection Agency. *Seminar Publication: Protection of Public Water Supplies from Ground-Water Contaminants*. Center for Environmental Research Information, Cincinnati, OH, 1985.

Waller, Roger M. *Ground Water and the Rural Homeowner*. U.S. Geological Survey, Reston, VA, 1988.



We welcome you to complete the assignment in Microsoft Word. You can easily find the assignment at www.abctlc.com. Once complete, just simply fax or e-mail the answer key along with the registration page to us and allow two weeks for grading. Once we grade it, we will mail a certificate of completion to you.

Call us if you need any help. If you need your certificate back within 48 hours, you may be asked to pay a rush service fee of \$50.00.

You can download the assignment in Microsoft Word from TLC's website under the Assignment Page. www.abctlc.com

You will have 90 days in order to successfully complete this assignment with a score of 70% or better. If you need any assistance, please contact TLC's Student Services.

Once you are finished, please mail, e-mail or fax your answer sheet along with your registration form.